

ELEIROTTEK **KABEL**® **GROUP**

INDUSTRIAL OIL AND GAS



ELETTROTEK **KABEL**® **GROUP**

Elettrotek Kabel was born in Italy at the end of 2001 with the aim of supply electrical cables for special applications in various sectors, particularly for industrial automation.

During these years the company has grown up creating a strengthened network thanks to the presence of different subsidiaries. These branches with their warehouses located in Switzerland, Germany and USA nowadays export to 45 Countries.

Elettrotek Kabel is one of the first companies in the world for the distribution of special electrical cables not only for industrial automation but also for steel, mining, offshore, marine and portual sectors.

This expansion is the result of Elettrotek Kabel's policy to put quality at first place always.

In 2012 Elettrotek Kabel became a S.p.A, signal of positivity and continuity between what has been done and what will be built.

In this moment Elettrotek Kabel is focusing on products' quality and specific customer care. Both these characteristics have allowed our group to grow up strongly and rapidly, enabling Elettrotek Kabel to become an established reality in the world.



Roberto Gallingani
General manager

WORLDWIDE PRESENCE

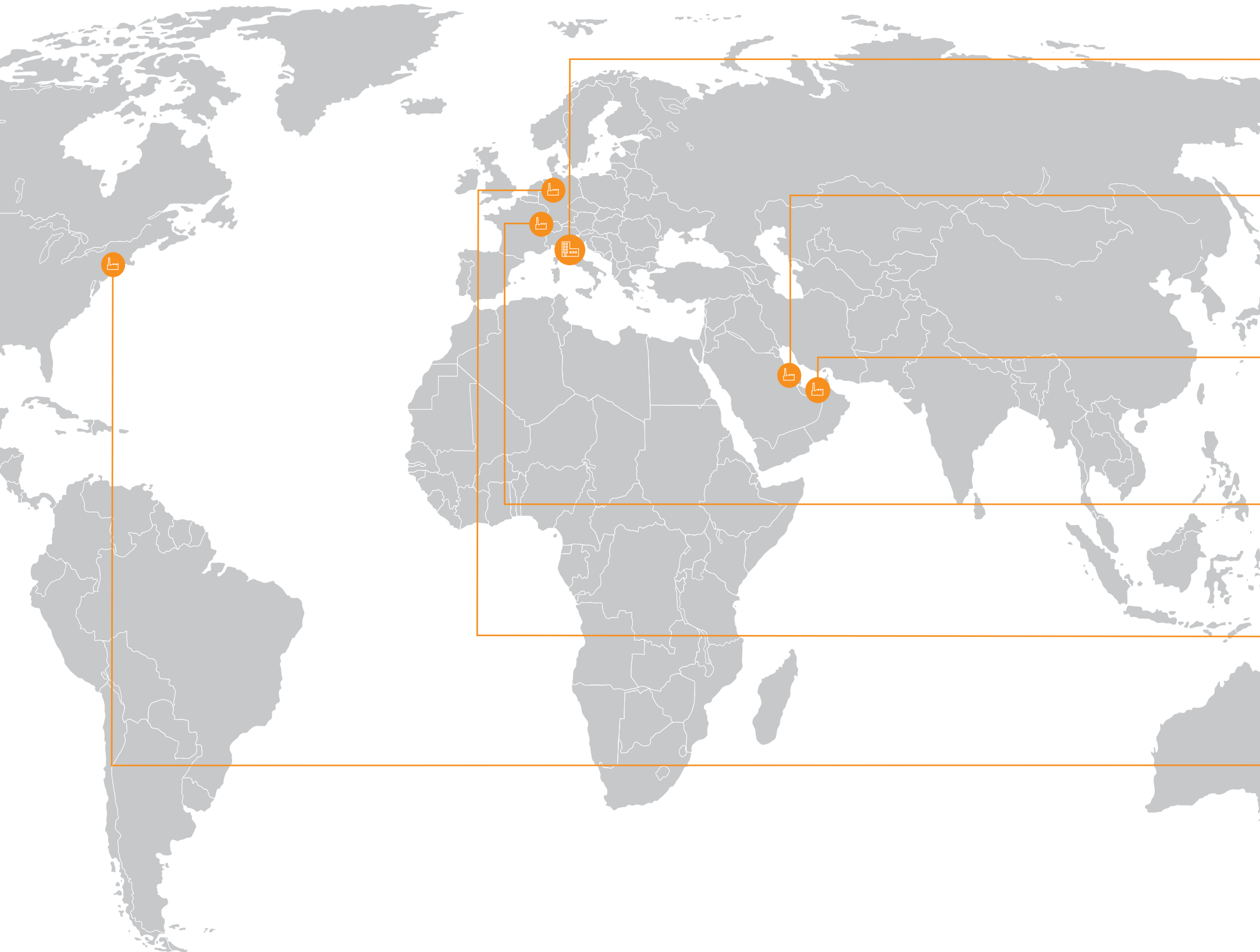

ELETTROTEK KABEL®

ELETTROTEK KABEL S.p.A.
Headquarter
Via Imerio Tondelli, 10
42011 Bagnolo in Piano - RE - Italy
Phone: +39 0522 956 001
Fax: +39 0522 953 655
Email: info@eletrotekkabel.com

ELETTROTEK KABEL® ABU DHABI

ELETTROTEK KABEL Middle East Electrical Equipment trading L.L.C.
SAS Investments Building Unit No. 401, Al Salam Street
Abu Dhabi Island
United Arab Emirates PO Box: 48238
Phone: +971 4 278 9621
Fax: +971 4 279 8399
Web: www.eletrotekkabel.com
mail: info@eletrotekkabel.ae

ELETTROTEK KABEL® MIDDLE EAST

ELETTROTEK KABEL Middle East DMCC
Unit 602, JBC2, plot JLT-PH2-V1A, Cluster V,
Jumeirah Lakes Towers, Dubai
United Arab Emirates PO Box 337077
Phone: +971 4 447 2551
Fax: +971 4 447 3690
Email: info@eletrotekkabel.ae

ELETTROTEK KABEL® SWISS

ELETTROTEK KABEL SWISS GmbH
Industriestrasse 18
8910 Affoltern am Albis - ZH - Switzerland
Phone: +41 (0) 44 760 36 80
Fax: +41 (0) 44 760 36 81
Email: contact@eletrotekkabel.ch

ELETTROTEK KABEL® GERMANY

ELETTROTEK KABEL GmbH
Erik-Geiershoefer-Str. 7
90584 Allersberg - Germany
Phone: +49 (0) 9176 36 797 46
Fax: +49 (0) 9176 36 797 47
Email: kontakt@eletrotekkabel.de

ELETTROTEK KABEL® NORTH AMERICA

ELETTROTEK KABEL NORTH AMERICA Inc.
2 Cranberry Road - Unit 5A
Parsippany, NJ - 07054 - USA
Phone: +1 973 265 0850
Fax: +1 973 265 0854
Email: info@eletrotekkabel.us

Industrial Low Voltage cables:

GAALFLEX® CONTROL N07V-K and H07V-K	2
GAALFLEX® CONTROL H05V-U/H07V-U and H07V-R	3
SG-Flex (H01N2-D)	4
FROR 300/500V and 450/750	5/6
FROH2R	7
FR2OHH2R	8
FRORAR 450/750 V	9/10
FG7(O)R 0,6/1 kV	11/12
RG7(O)R 0,6/1 kV	13/15
N1VV-K	16
FG7(O)HIR	17/18
FG7OH2R 0,6/1 kV	19/20
N1VC7V-K	21
GAALFLEX® VFD FG7(O)CR	22
GAALFLEX® VFD FG7(O)HH2R	23
FG7(O)NR 0,6/1 kV	24/25
FG7(O)RAR 0,6/1 kV	26/27
FG7(O)H2RAR 0,6/1 kV	28/29
FG7(O)HH2RAR 0,6/1 kV	30/31
GAALFLEX® CONTROL 1000 BH	32/33
FG7(O)MI 0,6/1 kV	34/35
FG7(O)H2MI 0,6/1 kV	36/37
FG7(O)AMI 0,6/1 kV	38/39
NY-Y-J/O 0,6/1 kV	40/42
(N)AY-Y-J/O 0,6/1 kV	43/44
NYCY	45/46
GAALFLEX® VFD NYCWY	47/48
(N)AYCWY	49
(N)2XY-J/O FR	50/52
U-1000 R2V	53/54
U-1000 RV FV	55/56
RV-K	57/58
RE4(O)R (XLPE/PVC)	59/60
FE4(O)CR	61
RE4(O)FR (XLPE/PVC/SWA/PVC)	62/64
RE4(O)FR (XLPE/PVC/SWA/PVC) BS 5467	65/67
RE4(O)MI (XLPE/LS0H)(RE4(O)H)	68/70
RE4(O)FM1 (XLPE/LS0H/SWA/LS0H)	71/72
N2XH	73/75
N2XCH	76/77
GAALFLEX® CONTROL 07BQ-F	78
GAALFLEX® CONTROL (H)07BQ-F	79

Industrial Medium Voltage cables:

RG7HIR	82/84
RG7HIOR	85/86
RG7HIONR	87/88
ARG7HIE	89
ARG7HIE X	90
RG7HIMI	91/93
RG7HIOMI	94/95
RG7HIONMI	96/97
RG7HIO(GS)MI	98
RE4HIR (XLPE/CTS/PVC)	99/100
RE4HIOR (XLPE/CTS/PVC)	101/102
RE4HIRFR (XLPE/CTS/PVC/AWA/PVC)	103/104
RE4HIORFR (XLPE/CTS/PVC/SWA/PVC)	105/106
ARE4HIR	107
ARE4HIRX	108
ARE4H5(GS)E	109/110
ARE4H5(GS)EX	111/112
RE4HIMI (XLPE/CTS/LS0H)	113/114
RE4HIOMI (XLPE/CTS/LS0H)	115/116
NSGAFOU 3 kV	117
NSHXAFO 3 kV	118
N2XS Y 6/10 kV, 12/20 kV, 18/30 kV PVC-jacket	119/120
N2XS2Y 6/10 kV, 12/20 kV, 18/30	121/122
N2XS(F)2Y 6/10 kV, 12/20 kV, 18/30 kV	123/124
N2XSEY 6/10 kV, 12/20 kV, 18/30 kV	125/126
NF2XSE(GS)Y or NFA2XSE(GS)Y	127/130
NA2XS Y 6/10 kV, 12/20 kV, 18/30 kV	131/132
NA2XS(F)2Y 6/10 kV, 12/20 kV, 18/30 kV	133/134
NA2X(FL)2Y 6/10 kV, 12/20 kV, 18/30 kV	135/136

Index

Instrumentation cables:

FR2XOHR 300/500 and 450/750 V	138/139
FR2XHOHR 300/500 V	140/141
FR2XOHRAR 450/750 V	142/143
FR2XHOHRAR 300/500 V	144/145
RD-Y(St)Y	146
REXOHR (PE/CAM/PVC)	147
REXHOHR (PE/IAM/CAM/PVC)	148/149
RE-2Y(St)Yv	150/152
RE-2Y(St)Yv-fl	153/155
RE-2Y(St)Y PiMF or TiMF	156/157
RE-2Y(St)Yv PiMF	158/159
RE-2Y(St)YRY twisted in pairs	160/161
RE-2Y(St)YRY	162/164
RE-2Y(St)YRY PiMF	165/166
RE-2Y(St)YRY 300 V	167/168
RE-2X(St)Y-fl	169/170
RE-2X(St)Yv PiMF	171/172
RE-2X(St)YRY	173/174
RE4XOHMI (XLPE/CAM/LS0H)	175
RE4XHOHMI (XLPE/IAM/CAM/LS0H)	176
RE4XOHEFR (XLPE/CAM/PE/SWA/PVC)	177
RE4XHOHMI FMI (XLPE/IAM/CAM/LS0H/SWA/ LS0H)	178

Security cables:

J-Y(St)Y Lg Fire warning	180/181
J-H(St)H Fire warning	182
JE-H(St)H Fire warning	183
JE-H(St)HRH Fire warning	184
JE-H(St)H Orange	185/186
FTG10(O)MI 0,6/1 kV	187/188
GAALFIRE 90 0,6/1 kV	189/190
N2XH-FE 180/E 30	191/192
N2XCH-FE 180/E 30	193/194
NHXH-FE 180/E 30	195/196
NHXCH-FE 180/E 30	197/198
N2XH-FE 180/E 90	199/200
N2XCH-FE 180/E 90	201/202
NHXH-FE 180/E 90	203/204
NHXCH-FE 180/E 90	205/206
FG4OHMI PH 30	207
GAALFIRE 90 450/750 V	208
GAALFIRE 120 450/750 V	209

Telephone and electronic cables:

A-2Y(L)2Y	212/213
A-2YF(L)2Y	214/215
A-Y(St)YSYv	216
J-YY Bd	217/218
J-Y(St)Y Lg	219/220
J-2Y(St)H	221
J-H(St)H	222
JE-Y(St)Y	223/224
JE-LiYCY	225/226
JE -LiHCH	227

Gaalship marine cables:

INTRODUCTION GAALSHIP® MARINE

GAALSHIP® MARINE Normatives	231
GAALSHIP® MARINE CABLES cores identification	232
GAALSHIP® DATA HF 350.....	233/234
GAALSHIP® DATA HF 350 A.....	235/236
GAALSHIP® DATA HF 350 A-TP.....	237/238
GAALSHIP® DATA HF 500 FRNC.....	239/240
GAALSHIP® DATA HF 500 A FRNC.....	241/242
GAALSHIP® N07G9-K	243
GAALSHIP® HF 1000.....	244/246
GAALSHIP® HF 1000 A.....	247/249
GAALSHIP® HF 1000 FR.....	250/252
GAALSHIP® HF 1000 A FR	253/255
GAALSHIP® HF 250 OS.....	256/257
GAALSHIP® HF 250 OS FR.....	258/260
GAALSHIP® HF 250 A	261/263
GAALSHIP® HF 250 A FR.....	264/266
GAALSHIP® HF 250 OSA.....	267/269
GAALSHIP® HF 250 OSA FR.....	270/272
GAALSHIP® HF 250 IS.....	273/274
GAALSHIP® HF 250 ISA.....	275/276
GAALSHIP® HF 250 ISOS.....	277/279
GAALSHIP® HF 250 ISOS FR.....	280/281
GAALSHIP® HF 250 ISOSA.....	282/284
GAALSHIP® HF 250 ISOSA FR.....	285/287
GAALSHIP® SFH... 1,8 kV to 12/20 kV	288/290
GAALSHIP® MFH... 1,8 kV to 12/20 kV.....	291/293
GAALSHIP® MARINE TECHNICAL DATA	294/295

Gaalship offshore cables:

“NEK” GAALSHIP® OFFSHORE

INTRODUCTION GAALSHIP® OFFSHORE

“NEK” GAALSHIP® OFFSHORE Normatives.....	299
“NEK” GAALSHIP® OFFSHORE CABLES cores identification	300
GAALSHIP® RU.....	302/303
GAALSHIP® RFOU.....	304/305
GAALSHIP® BU.....	306/307
GAALSHIP® BFOU.....	308/309
GAALSHIP® UX.....	310
GAALSHIP® VFD F-RFOU	311
GAALSHIP® RFOU 3,6/6 kV up to 12/20 kV	312/314
GAALSHIP® RU(i).....	315/316
GAALSHIP® RFOU(i).....	317/318
GAALSHIP® RU(c).....	319/320
GAALSHIP® RFOU(c).....	321/322
GAALSHIP® BU(i).....	323/324
GAALSHIP® BFOU(i).....	325/326
GAALSHIP® BU(c).....	327/328
GAALSHIP® BFOU(c).....	329/330

“BS” GAALSHIP® OFFSHORE

“BS” GAALSHIP® OFFSHORE Normatives.....	332
GAALSHIP® “BS” OFFSHORE CABLES cores identification.....	333
GAALSHIP® (RU 0,6/1 kV)	334/335
GAALSHIP® G (RFCU 0,6/1 kV)	336/337
GAALSHIP® FR.....	338/339
GAALSHIP® G FR (BFCU 0,6/1 kV)	340/341
GAALSHIP® G MEDIUM.....	342/344
GAALSHIP® TI	345/346
GAALSHIP® TO.....	347/348
GAALSHIP® TIG (RFCU(i) 250 V).....	349/350
GAALSHIP® TOG (RFCU(c) 250 V)	351/352
GAALSHIP® TIG FR (BFCU(i) 250 V)	353/354
GAALSHIP® TOG FR (BFCU(c) 250 V).....	355/356

“IEC” GAALSHIP® OFFSHORE

“IEC” GAALSHIP® OFFSHORE Normatives.....	358
“IEC” GAALSHIP® OFFSHORE Cores identification.....	359
GAALSHIP® LD RE4(O)A(CuSn)M1 or FE4(O)A(cuSn)M1 0,6/1 kV	360
GAALSHIP® LD RE4XOHM1A(CuSn)M1 or FE4XOHM1A(cuSn)M1 150/250V.....	361

GAALSHIP® OFFSHORE TECHNICAL DATA.....

“IEEE” GAALSHIP® OFFSHORE

GAALSHIP® POWER IEEE Type P SC	366
GAALSHIP® POWER IEEE Type P.....	367/368
GAALSHIP® POWER IEEE Type P B.....	369/370
GAALSHIP® POWER IEEE Type P BS.....	371/372
GAALSHIP® CONTROL IEEE Type P.....	373/374
GAALSHIP® CONTROL IEEE Type P B.....	375/376
GAALSHIP® CONTROL IEEE Type P BS.....	377/378
GAALSHIP® VFD IEEE Type P.....	379
GAALSHIP® VFD IEEE Type P TS	380
GAALSHIP® MEDIUM IEEE Type E SC, 5 kV - 8 kV - 15 kV	381/383
GAALSHIP® MEDIUM IEEE Type E SC BS, 5 kV - 8 kV - 15 kV	384/386
GAALSHIP® MEDIUM IEEE Type E 5 kV - 8 kV - 15 kV	387/389
GAALSHIP® MEDIUM IEEE Type E BS 5 kV - 8 kV - 15 kV	390/392
GAALSHIP® MEDIUM-VFD IEEE Type E TS 8 kV - 15 kV.....	393/394
GAALSHIP® INSTRUMENTATION IEEE Type E.....	395/396
GAALSHIP® INSTRUMENTATION IEEE Type E B.....	397/398
GAALSHIP® INSTRUMENTATION IEEE Type E BS.....	399/400
GAALSHIP® OFFSHORE IEEE TECHNICAL DATA	401

MANUFACTURE’S COMPARATIVE TABLE

CABLE GLANDS	404/416
TECHNICAL DATA	419/478



INDUSTRIAL LOW VOLTAGE CABLES



INDUSTRIAL LOW VOLTAGE CABLES

GAALFLEX® CONTROL N07V-K and H07V-K



CE

ELETTROTEK KABEL® N07V-K

Construction:

Conductor: flexible red copper conductor Cl.5, acc. to IEC 60228

Outer sheath: black (RAL 9005), PVC, type T11, for the other coloration, see technical data (PAG.428)

Resistance:



Flame retardant acc. to:
DIN VDE 0482 part 265-2-1
EN 50265-2-1
EN 60332-1 CEI 20-22II

Technical data:

Nominal voltage: 450/750 V

Test voltage: 2,5 kV

Temperature range: - 10 °C / + 70 °C

Max short circuit temperature: + 160 °C

Min. bending radius: $D \leq 8$ $8 < D \leq 12$ $12 < D \leq 20$ $D > 20$

Fixed laying: 3D 3D 4D 4D

Flexible application: 5D 5D 6D 6D

Features:

UNEL TABLE 35752

N07V-K

Part no.	No. of cores x cross section n x mm ²	Outer-Ø ca. mm ± 10%	Copper weight kg/km	Cable weight approx. kg/km	AWG no. *)
31380E01010M10	1x1	2,9	9,6	15	18
31380E01010M15	1x1,5	3,1	14,4	21	16
31380E01010M25	1x2,5	3,8	24	32	14
31380E01010M40	1x4	4,4	38,4	47	12
31380E01010M60	1x6	4,9	57,6	65	10
31380E01010M61	1x10	6,4	96	110	8
31380E01010M62	1x16	7,4	153,6	170	6
31380E01010M63	1x25	9,1	240	255	4
31380E01010M64	1x35	10,4	336	345	2
31380E01010M65	1x50	12,4	480	485	1
31380E01010M66	1x70	13,6	672	675	2/0
31380E01010M67	1x95	15,8	912	900	3/0
31380E01010M68	1x120	17,4	1152	1110	4/0
31380E01010M69	1x150	19,8	1440	1400	250 MCM
31380E01010M70	1x185	21,6	1776	1700	350 MCM
31380E01010M71	1x240	24,6	2304	2230	450 MCM

H07V-K

Part no.	No. of cores x cross section n x mm ²	Outer-Ø ca. mm ± 10%	Copper weight kg/km	Cable weight approx. kg/km	AWG no. *)
31320E01010M15	1x1,5	3,1	14,4	21	16
31320E01010M25	1x2,5	3,8	24	32	14
31320E01010M40	1x4	4,4	38,4	47	12
31320E01010M60	1x6	4,9	57,6	65	10
31320E01010M61	1x10	6,4	96	110	8
31320E01010M62	1x16	7,4	153,6	170	6
31320E01010M63	1x25	9,1	240	255	4
31320E01010M64	1x35	10,4	336	345	2
31320E01010M65	1x50	12,4	480	495	1
31320E01010M66	1x70	13,6	672	680	2/0
31320E01010M67	1x95	15,8	912	900	3/0
31320E01010M68	1x120	17,4	1152	1135	4/0
31320E01010M69	1x150	19,8	1440	1410	250 MCM
31320E01010M70	1x185	21,6	1776	1920	350 MCM
31320E01010M71	1x240	24,6	2304	2260	450 MCM

Other dimensions and colours available on request.

INDUSTRIAL LOW VOLTAGE CABLES

GAALFLEX® CONTROL H05V-U/H07V-U H07V-R



CE



Construction:

Conductor: solid or stranded red copper conductor
Cl. 1 or 2,
acc. to IEC 60228, DIN VDE 0295
0,5-1 mm² - H05V-U Cl.1
1,5-6 mm² - H07V-U Cl.1
6-400 mm² -H07V-R Cl.2

Outer sheath: black (RAL 9005),PVC,type T11,
for the other coloration,see technical
data (PAG.428)

Resistance:



Flame retardant acc. to:
DIN VDE 0482 part 265-2-1
EN 50265-2-1
EN 60332-1-2 CEI 20-22II

Technical data:

Nominal voltage

H05V-U: 300/500 V

H07V-U/R: 450/750 V

Test voltage

2,5 kV

H05V-U: 2 kV acc.to DIN VDE 0281 part 2 + HD 21.2

H07V-U/R: 2,5 kV acc.to DIN VDE 0281 part 2 + HD 21.2

Temperature range:

- 10 °C / + 70 °C

Max short circuit temperature:

+ 160 °C

Min. bending radius:

D≤8 8<D≤12 12<D≤20 D>20

Fixed laying:

3D 3D 4D 4D

Flexible application:

5D 5D 6D 6D

Features:

UNEL TABLE 35752

On request: acc.to BS 6004

Part no.	No.of cores x cross section n x mm ²	Outer-Ø ca.mm ± 10%	Copper weight kg/km	Cable weight approx. kg/km	AWG no.*)
31370D01010M05	1x0,5	2,1	4,8	9	20
31370D01010M07	1x0,75	2,3	7,2	12	19
31370D01010M10	1x1	2,5	9,6	15	18
31370E01010M15	1x1,5	2,9	14,4	19	16
31370E01010M25	1x2,5	3,5	24	32	14
31370E01010M40	1x4	4	38,4	47	12
31371E01010M60	1x6	4,7	57,6	65	10
31370E01010M61	1x10	6,1	96	112	8
31370E01010M62	1x16	7,1	153,6	168	6
31370E01010M63	1x25	8,9	240	265	4
31370E01010M64	1x35	9,9	336	355	2
31370E01010M65	1x50	11,7	480	485	1
31370E01010M66	1x70	13,3	672	675	2/0
31370E01010M67	1x95	15,8	912	940	3/0
31370E01010M68	1x120	17,2	1152	1170	4/0
31370E01010M69	1x150	19,1	1440	1440	250 MCM
31370E01010M70	1x185	21,3	1776	1820	350 MCM
31370E01010M71	1x240	24,3	2304	2340	450 MCM
31370E01010M72	1x300	27	2880	2940	600 MCM
31370E01010M73	1x400	30,3	3840	3740	900 MCM

Other dimensions and colours available on request.

INDUSTRIAL LOW VOLTAGE CABLES

SG-Flex (H01N2-D)



CE

ELETTROTEK KABEL® SG-Flex H01N2-D

Construction:

- Conductor:** flexible red copper conductor Cl.6, acc.to IEC 60228
- Outer sheath:** black (RAL 9005),rubber,type EM5, for the other coloration,see technical data (PAG.428)

Resistance:



Flame retardant acc. to:
DIN VDE 0482 part 265-2-1
EN 50265-2-1
EN 60332-1-2 CEI 20-22II



Oil resistant:
IEC 60811-2-1
DIN VDE 0473 part 811-2-1

Technical data:

- Nominal voltage:** 100/100 V
- Test voltage:** 1 kV
- Temperature range**
- Fixed laying:* - 40°C / +85°C
- Flexible application:* - 25°C / +85°C
- Max short circuit temperature:** + 250 °C
- Min. bending radius:** 8 x d

Features:

wires for arc welding, electrode holders for use with portable 100 V

Part no.	No.of cores x cross section n x mm ²	Outer-Ø ca.mm ± 10%	Copper weight kg/km	Cable weight approx. kg/km	AWG no.⁹)
31390B01010M61	1x10	8,7	96	135	8
31390B01010M62	1x16	9,9	154	198	6
31390B01010M63	1x25	11,4	240	285	4
31390B01010M64	1x35	12,8	336	385	2
31390B01010M65	1x50	14,85	480	550	0
31390B01010M66	1x70	17,25	672	750	2/0
31390B01010M67	1x95	19,25	912	1015	3/0
31390B01010M68	1x120	21,6	1152	1250	4/0
31390B01010M69	1x150	23,75	1440	1540	250 MCM
31390B01010M70	1x185	26	1776	1800	350 MCM

Other dimensions and colours available on request.

INDUSTRIAL LOW VOLTAGE CABLES

FROR 300/500V and 450/750V



ELETTROTEK KABEL® FROR

Construction:

- Conductor:** flexible red copper conductor Cl.5, acc. to IEC 60228
- Insulation:** PVC, type Tl2
- Colour cores:** acc. to DIN VDE 0293-308, HD 308 S2 from 6 cores black cores with consecutive numbers acc. to EN 50334; green-yellow earth-wire from 3 cores
- Outer sheath:** grey (RAL 7035), PVC, type TM2

Resistance:



Flame retardant acc. to:
DIN VDE 0482 part 265-2-1
EN 60332-1-2 CEI 20-22II



Corrosiveness of conflagration gases acc. to:
DIN VDE 0482 part 267
EN 50267-2-2
IEC 60754-2 (equivalent DIN VDE 0472 part 813)

Technical data:

Nominal voltage

- Control cables:* 300/500 V
- Power cables:* 450/750 V

Test voltage

- Control cables:* 2 kV
- Power cables:* 3 kV

Temperature range: - 10 °C / + 70 °C

Max short circuit temperature: + 160 °C

Min. bending radius

- Fixed laying:* 4 x d
- Flexible application:* 10 x d

Max. tensile stress: 15 N/mm²

Features:

according to IEC 60502-1

EN 60332-1-2 CEI 20-22II comparable to IEC 60332-3-22

300/500 V

Part no.	No. of cores x cross section n x mm ²	Outer-Ø ca. mm ± 10%	Copper weight kg/km	Cable weight approx. kg/km	AWG no. *)
46010D80071M10	7G1	11,1	67,2	165	18
46010D80101M10	10G1	14,3	96	240	18
46010D80121M10	12G1	14,8	115,2	270	18
46010D80161M10	16G1	16,5	153,6	350	18
46010D80191M10	19G1	17,7	182,4	400	18
46010D80241M10	24G1	20,7	230,4	510	18
46010D80271M10	27G1	21,4	259,2	610	18
46010D80071M15	7G1,5	13,1	100,8	230	16
46010D80101M15	10G1,5	16,7	144	340	16
46010D80121M15	12G1,5	17,5	172,8	380	16
46010D80161M15	16G1,5	19,4	230,4	480	16
46010D80191M15	19G1,5	20,5	273,6	560	16
46010D80241M15	24G1,5	24,3	345,6	700	16
46010D80271M15	27G1,5	25,0	388,8	770	16

Other dimensions and colours available on request.

INDUSTRIAL LOW VOLTAGE CABLES

FROR 300/500V and 450/750V



ELETTROTEK KABEL® FROR

450/750 V

Part no.	No. of cores x cross section n x mm ²	Outer-Ø ca. mm ± 10%	Copper weight kg/km	Cable weight approx. kg/km	AWG no. *)
46010E83020M10	2x1	8,7	19,2	165	18
46010E83020M15	2x1,5	9,2	28,8	240	16
46010E83020M25	2x2,5	11,2	48	270	14
46010E83020M40	2x4	12,5	76,8	350	12
46010E83020M60	2x6	13,9	115,2	400	10
46010E82031M10	3G1	9,1	28,8	510	18
46010E82031M15	3G1,5	9,8	43,2	610	16
46010E82031M25	3G2,5	11,9	72	230	14
46010E82031M40	3G4	13,5	115,2	340	12
46010E82031M60	3G6	14,9	172,8	380	10
46010E82041M10	4G1	9,9	38,4	480	18
46010E82041M15	4G1,5	10,9	57,6	560	16
46010E82041M25	4G2,5	12,9	96	700	14
46010E82041M40	4G4	14,7	153,6	770	12
46010E82041M60	4G6	16,3	230,4	405	10
46010E82051M10	5G1	11,1	48	150	18
46010E82051M15	5G1,5	12,0	72	180	16
46010E82051M25	5G2,5	14,3	120	265	14
46010E82051M40	5G4	16,5	192	375	12
46010E82051M60	5G6	18,0	288	495	10

Other dimensions and colours available on request.

ELETTROTEK KABEL® FROH2R

Construction:

Conductor:	flexible red copper conductor Cl.5, acc. to IEC 60228
Insulation:	PVC, type T12
Colour cores:	acc. to DIN VDE 0293-308, HD 308 S2 green-yellow earth-wire from 3 cores
Screen:	red copper braid
Outer sheath:	grey (RAL 7035), PVC, type TM2

Resistance:



Flame retardant acc. to:
DIN VDE 0482 part 265-2-1
EN 60332-1-2 CEI 20-22II



Corrosiveness of conflagration gases acc. to:
DIN VDE 0482 part 267
EN 50267-2-2
IEC 60754-2 (equivalent DIN VDE 0472 part 813)

Technical data:

Nominal voltage:	450/750 V
Test voltage:	2,5 kV
Temperature range:	- 10 °C / + 70 °C
Max short circuit temperature	
<i>Fixed laying:</i>	+ 160 °C
<i>Flexible application:</i>	+ 150 °C
Min. bending radius:	12 x d
Max. tensile stress:	50 N/mm ²

Features:

according to IEC 60502-1

EN 60332-1-2 CEI 20-22II comparable to IEC 60332-3-22

Part no.	No. of cores x cross section n x mm ²	Outer-Ø ca. mm ± 10%	Copper weight kg/km	Cable weight approx. kg/km	AWG no. *)
46020E83020M15	2x1,5	9	80,5	118,4	16
46020E82031M10	3x1	9	58,2	123,5	18
46020E82031M15	3G1,5	9,45	80,5	142,2	16
46020E82031M25	3G2,5	11,2	113	203,8	14
46020E82041M10	4G1	9,7	75,7	144,8	18
46020E82041M15	4G1,5	10,5	95,6	173,5	16
46020E82041M25	4G2,5	12,2	146,2	242,5	14
46020E82041M40	4G4	14,3	210,7	345,6	12
46020E82041M60	4G6	15,6	298,4	441,3	10
46020E82051M10	5G1	10,7	86,1	175,4	18
46020E82051M15	5G1,5	11,4	113,2	209	16
46020E82051M25	5G2,5	13,6	175	308	14
46020E82051M40	5G4	16	260	430,7	12
46020E82051M60	5G6	17,2	358,7	536,7	10

Other dimensions and colours available on request.

INDUSTRIAL LOW VOLTAGE CABLES

FR2OHH2R



ELETTROTEK KABEL® FR2OHH2R



Construction:

Conductor:	flexible red copper conductor Cl.5, acc. to IEC 60228
Insulation:	PVC, type R2
Colour cores:	acc. to DIN VDE 0293-308, HD 308 S2 green-yellow earth-wire from 3 cores
Screen:	aluminium tape and red copper braid
Outer sheath:	grey (RAL 7001), PVC, type Rz

Resistance:



Flame retardant acc. to:
DIN VDE 0482 part 265-2-1
EN 60332-1-2 CEI 20-22II



Corrosiveness of conflagration gases acc. to:
DIN VDE 0482 part 267
EN 50267-2-2
IEC 60754-2 (equivalent DIN VDE 0472 part 813)

Technical data:

Nominal voltage:	450/750 V
Test voltage:	2,5 kV
Temperature range:	- 10 °C / + 70 °C
Max short circuit temperature	
Fixed laying:	+ 160 °C
Flexible application:	+ 150 °C
Min. bending radius:	12 x d
Max. tensile stress:	50 N/mm ²

Features:

according to IEC 60502-1

EN 60332-1-2 CEI 20-22II comparable to IEC 60332-3-22

Part no.	No. of cores x cross section n x mm ²	Outer-Ø ca. mm ± 10%	Copper weight kg/km	Cable weight approx. kg/km	AWG no. *)
46030E83020M10	2x1	9,9	19,2	94	18
46030E83020M15	2x1,5	10,5	43,2	110	16
46030E83020M25	2x2,5	12,8	48	157	14
46030E83020M40	2x4	14,5	76,8	210	12
46030E83020M60	2x6	16,1	115,2	302	10
46030E82031M10	3G1	10,4	28,8	107	18
46030E82031M15	3G1,5	11,3	43,2	132	16
46030E82031M25	3G2,5	13,7	72	195	14
46030E82031M40	3G4	15,4	115,2	298	12
46030E82031M60	3G6	17	172,8	372	10
46030E82041M10	4G1	11,5	38,4	135	18
46030E82041M15	4G1,5	12,6	57,6	166	16
46030E82041M25	4G2,5	14,9	96	234	14
46030E82041M40	4G4	16,7	153,6	343	12
46030E82041M60	4G6	18,7	230,4	425	10
46030E82051M10	5G1	12	48	180	18
46030E82051M15	5G1,5	12,5	72	221	16
46030E82051M25	5G2,5	14,5	120	310	14
46030E82051M40	5G4	16,1	192	418	12
46030E82051M60	5G6	18,5	288	555	10

Other dimensions and colours available on request.

FRORAR 450/750V



Construction:

Conductor:	flexible red copper conductor Cl.5, acc. to IEC 60228
Insulation:	PVC, type R2
Colour cores:	black with numbered and Y/G earth-core
Inner sheath:	thermoplastic compound
Armour:	braid of galvanized steel wires
Outer sheath:	transparent, PVC, type TM2

Technical data:

Nominal voltage:	450/750 V
Test voltage:	2,5 kV
Temperature range:	- 10 °C / + 70 °C
Max short circuit temperature:	+ 160 °C
Min. bending radius:	8 x d

Resistance:



Flame retardant acc. to:
DIN VDE 0482 part 265-2-1
EN 60332-1-2 CEI 20-22II



Corrosiveness of conflagration gases acc. to:
DIN VDE 0482 part 267
EN 50267-2-2
IEC 60754-2 (equivalent DIN VDE 0472 part 813)

Features:

according to IEC 60502-1

EN 60332-1-2 CEI 20-22II comparable to IEC 60332-3-22

INDUSTRIAL LOW VOLTAGE CABLES

FRORAR 450/750V



Part no.	No. of cores x cross section n x mm ²	Outer-Ø ca. mm ± 10%	Copper weight kg/km	Cable weight approx. kg/km	AWG no. *)
46040ET1020M05	2x0,5	7,1	9,6	52	20
46040ET0031M05	3G0,5	7,3	14,4	64	20
46040ET0041M05	4G0,5	8	19,2	81	20
46040ET0051M05	5G0,5	8,4	24	96	20
46040ET0071M05	7G0,5	8,9	33,6	118	20
46040ET0101M05	10G0,5	10,9	48	210	20
46040ET0121M05	12G0,5	11,3	57,6	230	20
46040ET0161M05	16G0,5	12,6	76,8	260	20
46040ET0241M05	24G0,5	15,2	115,2	425	20
46040ET1020M07	2x0,75	7,7	14,4	70	19
46040ET0031M07	3G0,75	8	21,6	88	19
46040ET0041M07	4G0,75	8,7	28,8	108	19
46040ET0051M07	5G0,75	9,2	36	128	19
46040ET0071M07	7G0,75	10,2	50,4	190	19
46040ET0101M07	10G0,75	12,5	72	255	19
46040ET0121M07	12G0,75	13,0	86,4	290	19
46040ET0161M07	16G0,75	14,0	115,2	350	19
46040ET0241M07	24G0,75	16,9	345,6	497	19
46040ET1020M10	2x1	8,1	19,2	105	18
46040ET0031M10	3G1	8,4	28,8	120	18
46040ET0041M10	4G1	9	38,4	137	18
46040ET0051M10	5G1	10,2	48	198	18
46040ET0071M10	7G1	10,8	67,2	220	18
46040ET0101M10	10G1	13,3	96	340	18
46040ET0121M10	12G1	14,0	115,2	400	18
46040ET0161M10	16G1	15,8	153,6	490	18
46040ET0241M10	24G1	18,1	230,4	510	18
46040ET1020M15	2x1,5	9,1	28,8	135	16
46040ET0031M15	3G1,5	9,9	43,2	170	16
46040ET0041M15	4G1,5	10,6	57,6	200	16
46040ET0051M15	5G1,5	11,3	72	235	16
46040ET0071M15	7G1,5	12,5	100,8	275	16
46040ET0101M15	10G1,5	15,6	144	465	16
46040ET0121M15	12G1,5	16,3	172,8	495	16
46040ET0161M15	16G1,5	17,7	230,4	550	16
46040ET0241M15	24G1,5	21,4	345,6	750	16
46040ET1020M25	2x2,5	10,7	43,2	210	14
46040ET0031M25	3G2,5	11,2	72	240	14
46040ET0041M25	4G2,5	12,4	96	270	14
46040ET0051M25	5G2,5	13,3	120	340	14
46040ET0071M25	7G2,5	15,1	168	450	14
46040ET0101M25	10G2,5	18,2	240	590	14
46040ET0121M25	12G2,5	19,0	288	630	14
46040ET0161M25	16G2,5	21,3	384	750	14
46040ET0241M25	24G2,5	24,9	576	1190	14
46040ET1020M40	2x4	12,7	76,8	270	12
46040ET0031M40	3G4	13,3	115,2	310	12
46040ET0041M40	4G4	15,1	153,6	400	12
46040ET0051M40	5G4	16,3	192	480	12
46040ET1020M60	2x6	14,1	115,2	390	10
46040ET0031M60	3G6	15,4	172,8	445	10
46040ET0041M60	4G6	16,6	230,4	580	10
46040ET0051M60	5G6	17,9	288	700	10
46040ET1020M61	2x10	17,5	192	640	8
46040ET0031M61	3G10	18,6	288	700	8
46040ET0041M61	4G10	20,4	384	860	8
46040ET0051M61	5G10	22,5	480	1080	8
46040ET1020M62	2x16	19,9	307,2	950	6
46040ET0031M62	3G16	21,6	460,8	1130	6
46040ET0041M62	4G16	23,4	614,4	1360	6
46040ET1020M63	2x25	23,9	480	1450	4
46040ET0031M63	3G25	25,2	720	1675	4
46040ET0041M63	4G25	27,5	960	1910	4

Other dimensions and colours available on request.

FG7(O)R 0,6/1 kV



ELETTROTEK KABEL® FG7OR

Construction:

- Conductor:** flexible red copper conductor Cl.5, acc. to IEC 60228
- Insulation:** rubber, type G7
- Colour cores:** acc. to DIN VDE 0293-308, HD 308 S2 from 6 cores black cores with consecutive numbers acc. to EN 50334; green-yellow earth-wire from 3 cores
- Outer sheath:** grey (RAL 7035), PVC, type Rz

Resistance:



Flame retardant acc. to:
DIN VDE 0482 part 265-2-1
EN 60332-1-2 CEI 20-22II



Corrosiveness of conflagration gases acc. to:
DIN VDE 0482 part 267
EN 50267-2-2
IEC 60754-2 (equivalent DIN VDE 0472 part 813)

Technical data:

- Nominal voltage:** 0,6/1 kV
- Test voltage:** 4 kV
- Temperature range:** - 15 °C / + 90 °C
- Max short circuit temperature**
- for sections up to 240 mm²:* + 250 °C
- for sections over 240 mm²:* + 220 °C
- Min. bending radius**
- Power cables:* 4 x d
- Control cables:* 6 x d
- Max. tensile stress:** 50 N/mm²

Features:

- according to IEC 60502-1
- EN 60332-1-2 CEI 20-22II comparable to IEC 60332-3-22

Part no.	No. of cores x cross section n x mm ²	Outer-Ø ca. mm ± 10%	Copper weight kg/km	Cable weight approx. kg/km	AWG no. *)
46050G8L010M15	1x1,5	6,3	14,4	51	16
46050G8L010M25	1x2,5	6,85	24	64	14
46050G8L010M40	1x4	7,5	38,4	80	12
46050G8L010M60	1x6	8	57,6	105	10
46050G8L010M61	1x10	8,5	96	150	8
46050G8L010M62	1x16	10	153,6	200	6
46050G8L010M63	1x25	11	240	300	4
46050G8L010M64	1x35	12,5	336	390	2
46050G8L010M65	1x50	15	480	540	1
46050G8L010M66	1x70	17	672	740	2/0
46050G8L010M67	1x95	18,8	912	940	3/0
46050G8L010M68	1x120	21	1152	1200	4/0
46050G8L010M69	1x150	23,5	1440	1480	250 MCM
46050G8L010M70	1x185	26	1776	1830	350 MCM
46050G8L010M71	1x240	28,5	2304	2340	450 MCM
46050G8L010M72	1x300	32	2880	2950	550 MCM
46050G8L010M73	1x400	36,5	3840	3930	750 MCM
46050G83020M15	2x1.5	10	28,8	150	16
46050G83020M25	2x2.5	11	48	190	14
46050G83020M40	2x4	12,5	76,8	240	12
46050G83020M60	2x6	13,5	115	310	10
46050G83020M61	2x10	15	192	440	8
46050G83020M62	2x16	17	307	600	6
46050G83020M63	2x25	20	480	850	4
46050G83020M64	2x35	23	672	1130	2
46050G83020M65	2x50	27	960	1580	1
46050G83020M66	2x70	33	1344	2050	2/0

INDUSTRIAL LOW VOLTAGE CABLES

FG7(O)R 0,6/1 kV



ELETTROTEK KABEL® FG7OR



Part no.	No. of cores x cross section n x mm ²	Outer-Ø ca. mm ± 10%	Copper weight kg/km	Cable weight approx. kg/km	AWG no.*)
46050G82031M15	3G1.5	12,5	43,2	170	16
46050G82031M25	3G2.5	13,5	72	220	14
46050G82031M40	3G4	15	115,2	280	12
46050G82031M60	3G6	16	172	370	10
46050G82031M61	3G10	18	288	530	8
46050G82031M62	3G16	20,5	461	740	6
46050G82031M63	3G25	24,5	720	1060	4
46050G82031M64	3G35	27,5	1008	1420	2
46050G82031M65	3G50	31	1440	1960	1
46050G82031M66	3G70	35,5	2016	2700	2/0
46050G82031M67	3G95	40	2736	3430	3/0
46050G82031M68	3G120	44	3456	4406	4/0
46050G82040M15	4x1.5	12	57,5	200	16
46050G82040M25	4x2.5	13	96	260	14
46050G82040M40	4x4	14,5	153,5	330	12
46050G82040M60	4x6	16	230	430	10
46050G82040M61	4x10	18	384	640	8
46050G82040M62	4x16	22	614,5	900	6
46050G82040M63	4x25	25,5	960	1300	4
46050G83035M64	3x35+1x25	28,5	1248	1650	4
46050G82035M64	3x35+1G25	28,5	1248	1650	4
46050G83035M65	3x50+1x25	32,5	1680	2200	4
46050G82035M65	3x50+1G25	32,5	1680	2200	4
46050G83035M66	3x70+1x35	37	2352	3000	2
46050G82035M66	3x70+1G35	37	2352	3000	2
46050G83035M67	3x95+1x50	42	3216	3900	1
46050G82035M67	3x95+1G50	42	3216	3900	1
46050G83035M68	3x120+1x70	47	4128	4700	2/0
46050G82035M68	3x120+1G70	47	4128	4700	2/0
46050G83035M69	3x150+1x95	52,5	5232	6300	3/0
46050G82035M69	3x150+1G95	52,5	5232	6300	3/0
46050G83035M70	3x185+1x95	57,5	6240	7600	3/0
46050G82035M70	3x185+1G95	57,5	6240	7600	3/0
46050G83035M71	3x240+1x150	65,5	8352	10000	250
46050G82035M71	3x240+1G150	65,5	8352	10000	250
46050G82041M15	4G1.5	13,5	57,6	200	16
46050G82041M25	4G2.5	14,5	96	260	14
46050G82041M40	4G4	16	153,6	330	12
46050G82041M60	4G6	17,5	230,4	430	10
46050G82041M61	4G10	20	384	640	8
46050G82041M62	4G16	22,5	614,4	900	6
46050G82041M63	4G25	27	960	1300	4
46050G82051M15	5G1,5	14,5	72	230	16
46050G82051M25	5G2,5	15,5	120	310	14
46050G82051M40	5G4	17,5	192	400	12
46050G82051M60	5G6	19	288	520	10
46050G82051M61	5G10	21,5	480	780	8
46050G82051M62	5G16	24,5	768	1120	6
46050G82051M63	5G25	29,3	1200	1680	4
46050G82051M64	5G35	30,8	1680	2140	2
46050G82051M66	5G70	46,9	3360	3600	2/0
46050G81070M15	7G1,5	14,27	100,8	261	16
46050G81070M25	7G2,5	15,5	168	326,5	14
46050G81100M15	10G1,5	16,9	144	359	16
46050G81100M25	10G2,5	19,17	240	443,5	14
46050G81120M15	12G1,5	17,7	172,8	395	16
46050G81120M25	12G2,5	19,6	288	491	14
46050G81160M15	16G1,5	19,9	230,4	529,5	16
46050G81160M25	16G2,5	21,6	384	818	14
46050G81190M15	19G1,5	20,9	291,8	612	16
46050G81190M25	19G2,5	23,6	456	1019	14
46050G81240M15	24G1,5	23,8	345,6	733	16
46050G81240M25	24G2,5	27,1	576	1110	14

Other dimensions and colours available on request.

RG7(O)R 0,6/1 kV



ELETTROTEK KABEL® RG7OR

Construction:

Conductor:	solid or stranded red copper conductor Cl. 1 or 2, acc. to IEC 60228
Insulation:	Rubber type G7
Colour cores:	acc. to DIN VDE 0293-308, HD 308 S2 green-yellow earth-wire from 3 cores
Wrapping:	not fibrous and not hygroscopic filler
Outer sheath:	grey (RAL 7035), PVC, type Rz

Technical data:

Nominal voltage:	0,6/1 kV
Test voltage:	3,5 kV
Temperature range:	- 15 °C / + 90 °C
Max short circuit temperature	
<i>for sections up to 240 mm²:</i>	+ 250 °C
<i>for sections over 240 mm²:</i>	+ 220 °C
Min. bending radius:	6 x d
Max. tensile stress	
<i>during installation:</i>	50 N/mm²
<i>static stress:</i>	15 N/mm²

Resistance:



Flame retardant acc. to:
DIN VDE 0482 part 265-2-1
EN 60332-1-2 CEI 20-22II



Corrosiveness of conflagration gases acc. to:
DIN VDE 0482 part 267
EN 50267-2-2
IEC 60754-2 (equivalent DIN VDE 0472 part 813)

Features:

UNEL TABLES 35357 - 35376 - 35377

EN 60332-1-2 CEI 20-22II comparable to IEC 60332-3-22

Applications:

Power and control use outdoor and indoor applications, even wet. Suitable for fixed installation at open air, in tube or canals, masonry, metals structures, overhead wire and for direct and indirect underground wiring.

INDUSTRIAL LOW VOLTAGE CABLES

RG7(O)R 0,6/1 kV



ELETTROTEK KABEL® RG7OR

Part no.	No. of cores x cross section n x mm ²	Outer-Ø ca. mm ± 10%	Copper weight kg/km	Cable weight approx. kg/km	AWG no. *)
46060G8L010M15	1x1,5	6,4	14,4	50	16
46060G8L010M25	1x2,5	6,9	24	60	14
46060G8L010M40	1x4	7,5	38,4	80	12
46060G8L010M60	1x6	8,1	57,6	100	10
46060G8L010M61	1x10	9	96	150	8
46060G8L010M62	1x16	10	153,6	210	6
46060G8L010M63	1x25	11,7	240	320	4
46060G8L010M64	1x35	13	336	410	2
46060G8L010M65	1x50	14,7	480	530	1
46060G8L010M66	1x70	16,6	672	750	2/0
46060G8L010M67	1x95	18,6	912	1050	3/0
46060G8L010M68	1x120	20,5	1152	1300	4/0
46060G8L010M69	1x150	22,8	1440	1600	250 MCM
46060G8L010M70	1x185	25	1776	2000	350 MCM
46060G8L010M71	1x240	27,9	2304	2500	450 MCM
46060G8L010M72	1x300	30,7	2880	3100	550 MCM
46060G8L010M73	1x400	35	3840	3900	750 MCM
46060G8L010M74	1x500	38,6	4800	5000	950 MCM
46060G83020M15	2x1,5	11,5	28,8	140	16
46060G83020M25	2x2,5	12,4	48	180	14
46060G83020M40	2x4	13,6	76,8	220	12
46060G83020M60	2x6	14,7	115,2	280	10
46060G83020M61	2x10	16,6	192	430	8
46060G83020M62	2x16	18,6	307,2	600	6
46060G83020M63	2x25	22,1	480	930	4
46060G83020M64	2x35	24,6	672	1200	2
46060G83020M65	2x50	28,1	960	1600	1
46060G83020M66	2x70	31,7	1344	2200	2/0
46060G83020M67	2x95	35,9	1824	2900	3/0
46060G83020M68	2x120	39,8	2304	3500	4/0
46060G82031M15	3G1,5	12	43,2	170	16
46060G82031M25	3G2,5	13	72	210	14
46060G82031M40	3G4	14,3	115,2	270	12
46060G82031M60	3G6	15,5	172,8	360	10
46060G82031M61	3G10	17,5	288	540	8
46060G82031M62	3G16	19,7	460,8	770	6
46060G82031M63	3G25	23,4	720	1200	4
46060G82031M64	3G35	26,2	1008	1500	2
46060G82031M65	3G50	29,9	1440	2000	1
46060G82031M66	3G70	34,1	2016	2800	2/0
46060G82031M67	3G95	38,3	2736	3700	3/0
46060G82031M68	3G120	44,7	3456	4500	4/0
46060G82031M69	3G150	42,5	4320	5600	250 MCM
46060G82031M70	3G185	52,9	5328	6900	350 MCM
46060G82031M71	3G240	59,3	6912	8900	450 MCM

INDUSTRIAL LOW VOLTAGE CABLES

RG7(O)R 0,6/I kV



ELETTROTEK KABEL® RG7OR

Part no.	No. of cores x cross section n x mm ²	Outer-Ø ca. mm ± 10%	Copper weight kg/km	Cable weight approx. kg/km	AWG no. *)
46060G83040M15	4x1,5	12,9	57,6	210	16
46060G83040M25	4x2,5	14	96	260	14
46060G83040M40	4x4	15,4	153,6	350	12
46060G83040M60	4G6	16,7	230,4	460	10
46060G83040M61	4x10	19	384	700	8
46060G83040M62	4x16	21,5	614,4	1000	6
46060G83040M63	4x25	25,7	960	1500	4
46060G83035M64	3x35+1x25	28	1248	1800	2
46060G83035M65	3x50+1x25	31,1	1680	2200	1
46060G83035M66	3x70+1x35	35,4	2352	3100	2/0
46060G83035M67	3x95+1x50	40,3	3216	4100	3/0
46060G83035M68	3x120+1x70	44,9	4128	5200	4/0
46060G83035M69	3x150+1x95	50,3	5232	6400	250 MCM
46060G83035M70	3x185+1x95	54,9	6240	7800	350 MCM
46060G83035M71	3x240+1x150	62,8	8352	10300	450 MCM
46060G83035M72	3x300+1x150	67,8	10080	12300	550 MCM
46060G83035M73	3x400+1x240	78,8	13823	16200	750 MCM
46060G82035M64	3x35+1G25	28	1248	1800	2
46060G82035M65	3x50+1G25	31,1	1680	2200	1
46060G82035M66	3x70+1G35	35,4	2352	3100	2/0
46060G82035M67	3x95+1G50	40,3	3216	4100	3/0
46060G82035M68	3x120+1G70	44,9	4128	5200	4/0
46060G82035M69	3x150+1G95	50,3	5232	6400	250 MCM
46060G82035M70	3x185+1G95	54,9	6240	7800	350 MCM
46060G82035M71	3x240+1G150	62,8	8352	10300	450 MCM
46060G82035M72	3x300+1G150	67,8	10080	12300	550 MCM
46060G82035M73	3x400+1G240	78,8	13823	16200	750 MCM
46060G82051M15	5G1,5	13,8	260	260	16
46060G82051M25	5G2,5	15	330	330	14
46060G82051M40	5G4	16,5	460	460	12
46060G82051M60	5G6	18,1	288	570	10
46060G82051M61	5G10	20,6	480	860	8
46060G82051M62	5G16	23,4	768	1200	6
46060G82051M63	5G25	28	1200	1800	4
46060G82051M64	5G35	31,5	1680	2300	2
46060G82051M65	5G50	36,5	2400	3100	1

Other dimensions and colours available on request.

INDUSTRIAL LOW VOLTAGE CABLES

N1VV-K



ELETTROTEK KABEL® N1VV-K

Construction:

- Conductor:** flexible red copper conductor Cl.5, acc. to IEC 60228
- Insulation:** PVC, type R2
- Colour cores:** acc. to DIN VDE 0293-308, HD 308 S2 green-yellow earth-wire from 3 cores.
- Outer sheath:** light blue (RAL 5012), PVC, type Rz

Resistance:



Flame retardant acc. to:
DIN VDE 0482 part 265-2-1
EN 60332-1-2 CEI 20-22II



Corrosiveness of conflagration gases acc. to:
DIN VDE 0482 part 267
EN 50267-2-2
IEC 60754-2 (equivalent DIN VDE 0472 part 813)

Technical data:

- Nominal voltage:** 0,6/1 kV
- Test voltage:** 4 kV
- Temperature range:** 0 °C / + 70 °C
- Max short circuit temperature:** + 160 °C
- Min. bending radius**
- Power cables:* 4 x d
- Control cables:* 6 x d
- Max. tensile stress:** 50 N/mm²

Features:

according to IEC 60502-1 CEI 20-14, 20-11, 20-29, 20-67

Indoor and outdoor use

EN 60332-1-2 CEI 20-22II comparable to IEC 60332-3-22

Part no.	No. of cores x cross section n x mm ²	Outer-Ø ca. mm ± 10%	Copper weight kg/km	Cable weight approx. kg/km	AWG no. *)
46070GB3020M15	2x1,5	12,5	38,4	160	16
46070GB3020M25	2x2,5	13,4	48	200	14
46070GB3020M40	2x4	15,6	76,8	270	12
46070GB3020M60	2x6	16,8	115,2	350	10
46070GB3020M61	2x10	18,7	192	470	8
46070GB3020M62	2x16	20,9	307,2	670	6
46070GB3020M63	2x25	24,5	480	970	4
46070GB3020M64	2x35	27,1	672	1260	2
46070GB3020M65	2x50	31,2	960	1700	1
46070GB3020M66	2x70	34,8	1344	2300	2/0
46070GB2031M15	3G1,5	13,1	43,2	180	16
46070GB2031M25	3G2,5	14,1	72	240	14
46070GB2031M40	3G4	16,4	115,2	320	12
46070GB2031M60	3G6	17,7	172,8	400	10
46070GB2031M61	3G10	19,8	288	580	8
46070GB2031M62	3G16	22,1	460,8	820	6
46070GB2031M63	3G25	26	720	1200	4
46070GB2031M64	3G35	28,9	1008	1600	2
46070GB2031M65	3G50	33,3	1440	2150	1
46070GB2031M66	3G70	37,4	2016	2950	2/0
46070GB2031M67	3G95	42,8	2736	3800	3/0
46070GB2041M15	4G1,5	14,0	57,6	200	16
46070GB2041M25	4G2,5	15,2	96	270	14
46070GB2041M40	4G4	17,8	153,6	380	12
46070GB2041M60	4G6	19,2	230,4	480	10
46070GB2041M61	4G10	21,5	384	740	8
46070GB2041M62	4G16	24,2	614,4	1050	6
46070GB2041M63	4G25	28,5	960	1450	4
46070GB2051M15	5G1,5	15	72	250	16
46070GB2051M25	5G2,5	16,3	120	320	14
46070GB2051M40	5G4	19,2	192	450	12
46070GB2051M60	5G6	20,8	288	600	10
46070GB2051M61	5G10	23,4	480	880	8
46070GB2051M62	5G16	26,3	768	1220	6
46070GB2051M63	5G25	31,2	1200	1820	4

Other dimensions and colours available on request.

FG7(O)HIR 0,6/1 kV



ELETTROTEK KABEL® FG7OH1R



Construction:

Conductor:	flexible red copper conductor Cl.5, acc. to IEC 60228
Insulation:	rubber, type G7
Colour cores:	acc. to DIN VDE 0293-308, HD 308 S2 from 6 cores black cores with consecutive numbers acc. to EN 50334; green-yellow earth-wire from 3 core
Inner sheath:	filler compound
Screen:	two alternated copper tapes
Outer sheath:	grey (RAL 7035), PVC, type Rz

Technical data:

Nominal voltage:	0,6/1 kV
Test voltage:	3,5 kV
Temperature range:	-15 °C / + 90 °C
Max short circuit temperature:	+ 250 °C
Min. bending radius:	8 x d
tensile stress	
<i>during installation:</i>	50 N/mm ²
<i>static stress:</i>	15 N/mm ²

Resistance:



Flame retardant acc. to:
DIN VDE 0482 part 265-2-1
EN 60332-1-2 CEI 20-22II



Corrosiveness of conflagration gases acc. to:
DIN VDE 0482 part 267
EN 50267-2-2
IEC 60754-2 (equivalent DIN VDE 0472 part 813)

Features:

EN 60332-1-2 CEI 20-22II comparable to IEC 60332-3-22

Applications:

Power and control use outdoor and indoor applications, even wet. Suitable for fixed installation at open air, in tube or canals, masonry, metals structures, overhead wire and for direct and indirect underground wiring.
The most important property of this kind of cable is its protection against smokes, toxic and corrosive gases in case of fire.

INDUSTRIAL LOW VOLTAGE CABLES

FG7(O)HIR 0,6/1 kV



ELETTROTEK KABEL® FG7OH1R



Part no.	No. of cores x cross section n x mm ²	Outer-Ø ca. mm ± 10%	Cable weight approx. kg/km	AWG no. *)
46080G83020M15	2 x 1,5	12,5	241	16
46080G83020M25	2 x 2,5	13,5	280	14
46080G83020M40	2 x 4	14,5	336	12
46080G83020M60	2 x 6	15,5	395	10
46080G83020M61	2 x 10	18,5	567	8
46080G83020M62	2 x 16	20,5	738	6
46080G83020M63	2 x 25	25,2	1107	4
46080G83020M64	2 x 35	27,7	1403	2
46080G83020M65	2 x 50	30,5	1830	1
46080G83020M66	2 x 70	36,3	2571	2/0
46080G83020M67	2 x 95	39	3143	3/0
46080G83020M68	2 x 120	46,3	4316	4/0
46080G83020M69	2 x 150	52,7	5547	250
46080G82031M15	3 G 1,5	13	262	16
46080G82031M25	3 G 2,5	14	316	14
46080G82031M40	3 G 4	15	380	12
46080G82031M60	3 G 6	16	456	10
46080G82031M61	3 G 10	19,3	675	8
46080G82031M62	3 G 16	33,2	939	6
46080G82031M63	3 G 25	26,5	1346	4
46080G82031M64	3 G 35	29,2	1744	2
46080G82031M65	3 G 50	32,3	2262	1
46080G82031M66	3 G 70	38,4	3188	2/0
46080G82031M67	3 G 95	44	4309	3/0
46080G82031M68	3 G 120	51,5	5635	4/0
46080G82031M69	3 G 150	56,6	6921	250
46080G82031M70	3 G 185	60	8079	350
46080G82031M71	3 G 240	69,7	10639	450
46080G82041M15	4 G 1,5	13,7	298	16
46080G82041M25	4 G 2,5	14,8	357	14
46080G82041M40	4 G 4	16	438	12
46080G82041M60	4 G 6	17,3	535	10
46080G82041M61	4 G 10	20,8	802	8
46080G82041M62	4 G 16	24,6	1164	6
46080G82041M63	4 G 25	28,3	1664	4
46080G83035M64	3 x 35 + 1 x 25	31	2038	2
46080G83035M65	3 x 50 + 1 x 25	34,6	2606	1
46080G83035M66	3 x 70 + 1 x 35	40	3540	2/0
46080G83035M67	3 x 95 + 1 x 50	45,8	4818	3/0
46080G83035M68	3 x 120 + 1 x 70	53,8	6358	4/0
46080G83035M69	3 x 150 + 1 x 95	59	7852	250
46080G83035M70	3 x 185 + 1 x 95	62,8	9066	350
46080G83035M71	3 x 240 + 1 x 150	72,8	12078	450
46080G82051M15	5 G 1,5	15	351	16
46080G82051M25	5 G 2,5	16	424	14
46080G82051M40	5 G 4	17,5	527	12
46080G82051M60	5 G 6	18,9	653	10
46080G82051M61	5 G 10	23,5	1027	8
46080G82051M62	5 G 16	27	1415	6
46080G82051M63	5 G 25	31,6	2022	4
46080G80071M15	7 G 1,5	15,7	399	16
46080G80071M25	7 G 2,5	17	496	14
46080G80101M15	10 G 1,5	17,8	503	16
46080G80101M25	10 G 2,5	19,5	644	14
46080G80121M15	12 G 1,5	19,2	574	16
46080G80121M25	12 G 2,5	21	732	14
46080G80161M15	16 G 1,5	21	690	16
46080G80161M25	16 G 2,5	24	950	14
46080G80191M15	19 G 1,5	24,5	813	16
46080G80191M25	19 G 2,5	28,2	1056	14

Other dimensions and colours available on request.

FG7OH2R 0,6/1 KV



ELETTROTEK KABEL® FG7OH2R

Construction:

- Conductor:** flexible red copper conductor Cl.5, acc. to IEC 60228
- Insulation:** rubber, type G7
- Colour cores:** acc. to DIN VDE 0293-308, HD 308 S2 from 6 cores black cores with consecutive numbers acc. to EN 50334; green-yellow earth-wire from 3 core
- Inner sheath:** thermoplastic compound
- Screen:** red copper braid
- Outer sheath:** grey (RAL 7035), PVC, type Rz

Resistance:



Flame retardant acc. to:
DIN VDE 0482 part 265-2-1
EN 60332-1-2 CEI 20-22II



Corrosiveness of conflagration gases acc. to:
DIN VDE 0482 part 267
EN 50267-2-2
IEC 60754-2 (equivalent DIN VDE 0472 part 813)

Technical data:

- Nominal voltage:** 0,6/1 kV
- Test voltage:** 4 kV
- Temperature range:** - 15 °C / + 90 °C
- Max short circuit temperature:** + 250 °C
- Min. bending radius:** 8 x d
- Max. tensile stress:** 50 N/mm²

Features:

- according to IEC 60502-1
- EN 60332-1-2 CEI 20-22II comparable to IEC 60332-3-22

Part no.	No. of cores x cross section n x mm ²	Outer-Ø ca. mm ± 10%	Copper weight kg/km	Cable weight approx. kg/km	AWG no. (*)
46090G8L010M61	1X10	9,5	139	-	8
46090G8L010M62	1X16	10,5	198	-	6
46090G8L010M63	1X25	12	283,5	-	4
46090G8L010M64	1X35	14,5	378	-	2
46090G8L010M65	1X50	16,5	522	-	1
46090G8L010M66	1X70	17,5	729	-	2/0
46090G8L010M67	1X95	20	967,5	-	3/0
46090G8L010M68	1X120	23	1219	-	4/0
46090G8L010M69	1X150	26	1512	-	250 MCM
46090G8L010M70	1X185	29,5	1858	-	350 MCM
46090G8L010M71	1X240	32	2394	-	450 MCM
46090G83020M15	2X1,5	12,5	72	241	16
46090G83020M25	2X2,5	13,5	90	280	14
46090G83020M40	2X4	15	121,5	336	12
46090G83020M60	2X6	16	157,5	395	10
46090G83020M61	2X10	18	238,5	567	8
46090G83020M62	2X16	20,5	364,5	738	6
46090G83020M63	2X25	24	558	1107	4
46090G83020M64	2X35	26,5	738	1403	2
46090G83020M65	2X50	30,5	1048,5	1830	1

INDUSTRIAL LOW VOLTAGE CABLES

FG7OH2R 0,6/1 KV



ELETTROTEK KABEL® FG7OH2R

Part no.	No. of cores x cross section n x mm ²	Outer-Ø ca. mm ± 10%	Copper weight kg/km	Cable weight approx. kg/km	AWG no. *)
46090G82031M15	3G1,5	13,5	85,5	262	16
46090G82031M25	3G2,5	14,5	117	316	14
46090G82031M40	3G4	15,5	157,5	380	12
46090G82031M60	3G6	17	216	456	10
46090G82031M61	3G10	19	342	675	8
46090G82031M62	3G16	21,5	517,5	939	6
46090G82031M63	3G25	25,5	801	1346	4
46090G82031M64	3G35	28,5	1093	1744	2
46090G82031M65	3G50	32,5	1543	2262	1
46090G82031M66	3G70	37	2155,5	3188	2/0
46090G82031M67	3G95	41	2889	4309	3/0
46090G82031M68	3G120	46	3636	5635	4/0
46090G82031M69	3G150	51	4554	6921	250 MCM
46090G82041M15	4G1.5	14	99	298	16
46090G82041M25	4G2.5	15,5	139,5	357	14
46090G82041M40	4G4	16,5	198	438	12
46090G82041M60	4G6	18,5	274,5	535	10
46090G82041M61	4G10	21	445,5	802	8
46090G82041M62	4G16	23,5	688,5	1164	6
46090G82041M63	4G25	28	1048,5	1664	4
46090G82035M64	3X35+25	30,4	-	2038	2
46090G82035M65	3X50+25	33,6	-	2606	1
46090G82035M66	3X70+35	38,2	-	3540	2/0
46090G82035M67	3X95+50	43,4	-	4818	3/0
46090G82035M68	3X120+70	48,3	-	6358	4/0
46090G82035M69	3X150+95	53,9	-	7852	250 MCM
46090G82051M15	5G1.5	15,1	117	351	16
46090G82051M25	5G2.5	16,4	162	424	14
46090G82051M40	5G4	18,2	234	527	12
46090G82051M60	5G6	19,8	342	653	10
46090G82051M61	5G10	22,4	549	1027	8
46090G82051M62	5G16	25,4	846	1415	6
46090G82051M63	5G25	30,5	1300,5	2022	4
46090G82051M64	5G35	34,0	1809	-	2
46090G82051M65	5G50	39,4	2556	-	1
46090G80071M15	7G1,5	15,1	144	399	16
46090G80101M15	10G1,5	19,7	202,5	503	16
46090G80121M15	12G1,5	20,2	238,5	574	16
46090G80161M15	16G1,5	22	301,5	690	16
46090G80191M15	19G1,5	23	346,5	813	16
46090G80241M15	24G1,5	26,4	432	972	16
46090G80071M25	7G2,5	17,8	211,5	1218	14
46090G80101M25	10G2,5	21,6	297	644	14
46090G80121M25	12G2,5	22,2	360	732	14
46090G80161M25	16G2,5	24,3	459	950	14
46090G80191M25	19G2,5	25,4	535,5	1056	14
46090G80241M25	24G2,5	29,3	675	1281	14

Other dimensions and colours available on request.



Construction:

Conductor:	flexible red copper conductor Cl.5, acc. to IEC 60228
Insulation:	PVC, type R2
Colour cores:	acc. to DIN VDE 0293-308, HD 308 S2 from 6 cores black cores with consecutive numbers acc. to EN 50334; green-yellow earth-wire from 3 core
Wrapping:	not fibrous and hygroscopic materials
Screen:	two alternated copper tapes
Outer sheath:	light blue (RAL 5012), PVC, type Rz

Technical data:

Nominal voltage:	0,6/1 kV
Test voltage:	4 kV
Temperature range:	- 10 °C / + 70 °C
Max short circuit temperature:	+ 160 °C
Min. bending radius:	8 x d
Tensile stress	
<i>during installation:</i>	50 N/mm ²
<i>static stress:</i>	15 N/mm ²

Resistance:



Flame retardant acc. to:
DIN VDE 0482 part 265-2-1
EN 60332-1-2 CEI 20-22II



Corrosiveness of conflagration gases acc. to:
DIN VDE 0482 part 267
EN 50267-2-2
IEC 60754-2 (equivalent DIN VDE 0472 part 813)

Features:

EN 60332-1-2 CEI 20-22II comparable to IEC 60332-3-22
according to CEI 20-14
UNEL TABLES 35357 - 35376
Indoor and outdoor use

Part no.	No. of cores x cross section n x mm ²	Outer-Ø ca. mm ± 10%	Cable weight approx. kg/km	AWG no. *)
46100GB3020M15	2x1,5	13,4	250	16
46100GB3020M25	2x2,5	14,7	310	14
46100GB3020M40	2x4	16,3	410	12
46100GB3020M60	2x6	17,3	460	10
46100GB3020M61	2x10	19,3	580	8
46100GB3020M62	2x16	22,8	820	6
46100GB3020M63	2x25	27,2	1180	4
46100GB2031M15	3G1,5	13,8	270	16
46100GB2031M25	3G2,5	15,2	360	14
46100GB2031M40	3G4	16,8	420	12
46100GB2031M60	3G6	18	500	10
46100GB2031M61	3G10	20,3	700	8
46100GB2031M62	3G16	24,3	1020	6
46100GB2031M63	3G25	28	1450	4
46100GB2041M15	4G1,5	14,6	310	16
46100GB2041M25	4G2,5	16,2	390	14
46100GB2041M40	4G4	18	480	12
46100GB2041M60	4G6	19,3	600	10

Other dimensions and colours available on request.

INDUSTRIAL LOW VOLTAGE CABLES

GAALFLEX® VFD FG7(O)CR

inverter, connection to frequency converters



ELETTROTEK KABEL® FG7OCR



Construction:

Conductor:	flexible red copper conductor Cl.5, acc. to IEC 60228
Insulation:	rubber, type G7
Colour cores:	acc. to DIN VDE 0293-308, HD 308 (brown - gray - black)
Stranding:	cores laying to concentric crowns to ensure roundness to the cable
Inner sheath:	PVC, type R2
Screen:	red copper braid
Outer sheath:	grey (RAL 7035), PVC, type Rz

Resistance:



Flame retardant acc. to:
DIN VDE 0482 part 265-2-1
EN 60332-1-2 CEI 20-22II



Corrosiveness of conflagration gases acc. to:
DIN VDE 0482 part 267
EN 50267-2-2
IEC 60754-2 (equivalent DIN VDE 0472 part 813)

Technical data:

Nominal voltage:	0,6/1 kV
Test voltage:	4 kV
Temperature range:	- 20 °C / + 90 °C
Max short circuit temperature:	+ 250 °C
Min. bending radius:	8 x d

Features:

according to IEC 60502-1 and CEI 20-13 CEI-UNEL 35375

EN 60332-1-2 CEI 20-22II comparable to IEC 60332-3-22

Part no.	No. of cores x cross section n x mm ²	Outer-Ø ca. mm ± 10%	Copper weight kg/km	Cable weight approx. kg/km	AWG no. *)
33190G83030M25	3x2,5+SH	14,6	96	340	14
33190G83030M40	3x4+SH	15,8	134	400	12
33190G83030M60	3x6+SH	18,7	231	490	10
33190G83030M61	3x10+SH	21,7	336	720	8
33190G83030M62	3x16+SH	25,3	615	1040	6
33190G83030M63	3x25+SH	28,8	873	1410	4
33190G83030M64	3x35+SH	32,2	1162	1870	2
33190G83030M65	3x50+SH	36	1680	2400	1
33190G83030M66	3x70+SH	40,7	2352	3360	2/0
33190G83030M67	3x95+SH	47,6	3192	4350	3/0
33190G83030M68	3x120+SH	52,2	4032	5540	4/0
33190G83030M69	3x150+SH	56,4	5040	6880	250 MCM
33190G83030M70	3x185+SH	64,8	6216	8350	350 MCM
33190G83030M71	3x240+SH	74,5	8604	11540	450 MCM
33190G83030M72	3x300+SH	85,5	10080	13480	550 MCM

Other dimensions and colours available on request.

INDUSTRIAL LOW VOLTAGE CABLES

GAALFLEX® VFD FG7OHH2R

0,6/1 KV inverter, connection to frequency converters



ELETTROTEK KABEL® FG7OHH2R



Construction:

- Conductor:** flexible red copper conductor Cl.5, acc. to IEC 60228
- Insulation:** rubber, type G7
- Colour cores:** acc. to DIN VDE 0293-308, HD 308 (brown - gray - black)
- Inner sheath:** PVC, type Rz
- Screen:** aluminium stripe (100% covering), red copper braid of the same section as the phase conductor (for sections up to 16 mm²) or equal to half phase conductor, with a minimum of 16 mm² (for section greater than 25 mm²)
- Outer sheath:** grey (RAL 7001), PVC, type Rz

Resistance:



Flame retardant acc. to:
DIN VDE 0482 part 265-2-1
EN 60332-1-2 CEI 20-22II



Corrosiveness of conflagration gases acc. to:
DIN VDE 0482 part 267
EN 50267-2-2
IEC 60754-2 (equivalent DIN VDE 0472 part 813)

Technical data:

- Nominal voltage:** 0,6/1 kV
- Test voltage:** 4 kV
- Temperature range:** - 15 °C / + 90 °C
- Max short circuit temperature:** + 250 °C
- Min. bending radius:** 8 x d

Features:

according to IEC 60502-1 and CEI 20-13 CEI-UNEL 35375

on request: FG7OHH2M1-0,6/1 kV, Halogen free Version with green M1 LS0H thermoplastic sheath

EN 60332-1-2 CEI 20-22II comparable to IEC 60332-3-22

Part no.	No. of cores x cross section n x mm ²	Outer-Ø ca. mm ± 10%	Copper weight kg/km	Cable weight approx. kg/km	AWG no. *)
33170G83030M25	3x2,5+SH	14,6	96	340	14
33170G83030M40	3x4+SH	15,8	134	400	12
33170G83030M60	3x6+SH	18,5	231	490	10
33170G83030M61	3x10+SH	21	336	720	8
33170G83030M62	3x16+SH	23,5	615	1040	6
33170G83030M63	3x25+SH	27	873	1410	4
33170G83030M64	3x35+SH	30,5	1162	1870	2
33170G83030M65	3x50+SH	35	1680	2400	1
33170G83030M66	3x70+SH	40	2352	3360	2/0
33170G83030M67	3x95+SH	45	3192	4350	3/0
33170G83030M68	3x120+SH	50	4032	5540	4/0
33170G83030M69	3x150+SH	55,4	5040	6880	250 MCM
33170G83030M70	3x185+SH	61,5	6216	8350	350 MCM
33170G83030M71	3x240+SH	68	8604	11540	450 MCM
33170G83030M72	3x300+SH	73,5	10080	13480	550 MCM

Other dimensions and colours available on request.

FG7(O)NR 0.6/1 kV



ELETTROTEK KABEL® FG7ONR

Construction:

Conductor:	flexible red copper conductor Cl.5, acc. to IEC 60228
Insulation:	rubber, type G7
Colour cores:	acc. to DIN VDE 0293-308, HD 308 S2 from 6 cores black cores with consecutive numbers acc. to EN 50334; green-yellow earth-wire from 3 cores
Inner sheath:	PVC, type Rz
Armour:	steel tapes
Outer sheath:	grey (RAL 7035), PVC, type Rz

Technical data:

Nominal voltage:	0,6/1 kV
Test voltage:	4 kV
Temperature range:	0 °C / + 90 °C
Max short circuit temperature:	+ 250 °C
Min. bending radius:	14 x d

Resistance:



Flame retardant acc. to:
DIN VDE 0482 part 265-2-1
EN 60332-1-2 CEI 20-22II



Corrosiveness of conflagration gases acc. to:
DIN VDE 0482 part 267
EN 50267-2-2
IEC 60754-2 (equivalent DIN VDE 0472 part 813)

Features:

according to IEC 60502-1

EN 60332-1-2 CEI 20-22II comparable to IEC 60332-3-22

INDUSTRIAL LOW VOLTAGE CABLES

FG7(O)NR 0.6/1 kV



ELETTROTEK KABEL® FG7ONR



Part no.	No. of cores x cross section n x mm ²	Outer-Ø ca. mm ± 10%	Copper weight kg/km	Cable weight approx. kg/km	AWG no. *)
46110G83020M15	2x1,5	13,5	28,8	265	16
46110G83020M25	2x2,5	14,4	48	310	14
46110G83020M40	2x4	15,6	76,8	370	12
46110G83020M60	2x6	16,6	115,2	430	10
46110G83020M61	2x10	19,4	192	610	8
46110G83020M62	2x16	21,5	307,2	790	6
46110G83020M63	2x25	26,3	480	1180	4
46110G83020M64	2x35	28,8	672	1460	2
46110G83020M65	2x50	31,6	960	1910	1
46110G83020M66	2x70	37,8	1344	2750	2/0
46110G83020M67	2x95	40,4	1824	3330	3/0
46110G83020M68	2x120	47,8	2304	4540	4/0
46110G83020M69	2x150	54,3	2880	5800	300 MCM
46110G82031M15	3G1,5	14	43,2	300	16
46110G82031M25	3G2,5	15	72	350	14
46110G82031M40	3G4	16	115,2	420	12
46110G82031M60	3G6	17,2	172,8	500	10
46110G82031M61	3G10	20,4	288	730	8
46110G82031M62	3G16	23,4	460,8	1000	6
46110G82031M63	3G25	27,7	720	1420	4
46110G82031M64	3G35	30,3	1008	1830	2
46110G82031M65	3G50	33,4	1440	2360	1
46110G82031M66	3G70	39,9	2016	3380	2/0
46110G82031M67	3G95	45,7	2736	4530	3/0
46110G82031M68	3G120	53,1	3456	5890	4/0
46110G82031M69	3G150	58	4320	7200	300 MCM
46110G82031M70	3G185	61,7	5328	8390	350 MCM
46110G82031M71	3G240	71,2	6912	11000	500 MCM
46110G83035M64	3x35+1x25	32,2	1248	2107	2
46110G83035M65	3x50+1x25	35,7	1680	2694	1
46110G83035M66	3x70+1x35	41,3	2352	3714	2/0
46110G83035M67	3x95+1x50	47,3	3216	5014	3/0
46110G83035M68	3x120+1x70	55,4	4128	6594	4/0
46110G83035M69	3x150+1x95	60,5	5232	8109	300 MCM
46110G83035M70	3x185+1x95	64,3	6240	9340	350 MCM
46110G83035M71	3x240+1x150	74,2	8352	12395	500 MCM
46110G82041M15	4G1,5	14,8	57,6	315	16
46110G82041M25	4G2,5	15,8	96	380	14
46110G82041M40	4G4	17,2	153,6	469	12
46110G82041M60	4G6	18,5	230,4	572	10
46110G82041M61	4G10	22	384	846	8
46110G82041M62	4G16	25,8	614,4	1216	6
46110G82041M63	4G25	29,8	960	1729	4
46110G82051M15	5G1,5	16	72	390	16
46110G82051M25	5G2,5	17	120	470	14
46110G82051M40	5G4	18,6	192	580	12
46110G82051M60	5G6	20	288	700	10
46110G82051M61	5G10	24,7	480	1090	8
46110G82051M62	5G16	27,9	768	1490	6
46110G82051M63	5G25	32,7	1200	2110	4
46110G80071M15	7G1,5	16,7	100,8	440	16
46110G80071M25	7G2,5	18,3	168	550	14
46110G80101M15	10G1,5	18,8	144	490	16
46110G80101M25	10G2,5	20,6	240	700	14
46110G80121M15	12G1,5	20,4	172,8	630	16
46110G80121M25	12G2,5	22,3	288	800	14
46110G80161M15	16G1,5	22	230,4	750	16
46110G80161M25	16G2,5	25	384	1020	14
46110G80191M15	19G1,5	23,7	273,6	880	16
46110G80191M25	19G2,5	26	456	1130	14
46110G80241M15	24G1,5	26,6	345,6	1050	16
46110G80241M25	24G2,5	29,4	576	1370	14

Other dimensions and colours available on request.

INDUSTRIAL LOW VOLTAGE CABLES

FG7(O)RAR 0.6/1 kV



ELETTROTEK KABEL® FG7ORAR

Construction:

Conductor:	flexible red copper conductor Cl.5, acc. to IEC 60228
Insulation:	rubber, type G7
Colour cores:	acc. to DIN VDE 0293-308, HD 308 S2 from 6 cores black cores with consecutive numbers acc. to EN 50334; green-yellow earth-wire from 3 cores
Inner sheath:	PVC compound
Armour:	braid of galvanized steel wires
Outer sheath:	grey (RAL 7035), PVC, type Rz

Resistance:



Flame retardant acc. to:
DIN VDE 0482 part 265-2-1
EN 60332-1-2 CEI 20-22II



Corrosiveness of conflagration gases acc. to:
DIN VDE 0482 part 267
EN 50267-2-2
IEC 60754-2 (equivalent DIN VDE 0472 part 813)

Technical data:

Nominal voltage:	0,6/1 kV
Test voltage:	4 kV
Temperature range:	- 15 °C / + 90 °C
Max short circuit temperature:	+ 250 °C
Min. bending radius:	10 x d

Features:

according to IEC 60502-1

EN 60332-1-2 CEI 20-22II comparable to IEC 60332-3-22

INDUSTRIAL LOW VOLTAGE CABLES

FG7(O)RAR 0.6/1 kV



ELETTROTEK KABEL® FG7ORAR



Part no.	No. of cores x cross section n x mm ²	Outer-Ø ca. mm ± 10%	Copper weight kg/km	Cable weight approx. kg/km	AWG no. *)
46120G83020M15	2x1,5	10,3	28,8	162	16
46120G82031M15	3G1,5	10,8	48	188	16
46120G82041M15	4G1,5	11,6	57,6	212	16
46120G82051M15	5G1,5	12,5	72	237	16
46120G80071M15	7G1,5	13,4	100,8	273	16
46120G80101M15	10G1,5	16,4	144	399	16
46120G80121M15	12G1,5	17,2	172,8	481	16
46120G80161M15	16G1,5	19,1	230,4	596	16
46120G80191M15	19G1,5	20,2	273,6	666	16
46120G80241M15	24G1,5	22,8	345,6	861	16
46120G80301M15	30G1,5	24,6	432	1029	16
46120G80361M15	36G1,5	26,7	518,4	1197	16
46120G80481M15	48G1,5	30,3	691,2	1470	16
46120G83020M25	2x2,5	11,4	48	190	14
46120G82031M25	3G2,5	12	72	230	14
46120G82041M25	4G2,5	12,9	96	268	14
46120G82051M25	5G2,5	14	120	328	14
46120G80071M25	7G2,5	15,3	168	407	14
46120G80101M25	10G2,5	18,7	240	579	14
46120G80121M25	12G2,5	19,7	288	671	14
46120G80161M25	16G2,5	21,9	384	824	14
46120G80191M25	19G2,5	23	456	947	14
46120G80241M25	24G2,5	26,1	576	1187	14
46120G80301M25	30G2,5	28,3	720	1520	14
46120G80361M25	36G2,5	30,5	864	1640	14
46120G83020M40	2x4	12,7	76,8	242	12
46120G82031M40	3G4	13,3	115,2	299	12
46120G82041M40	4G4	14,7	153,6	360	12
46120G82051M40	5G4	15,9	192	410	12
46120G80071M40	7G4	17,4	268,8	530	12
46120G80101M40	10G4	21,5	384	851	12
46120G80121M40	12G4	22,5	460,8	989	12
46120G80161M40	16G4	25,1	614,4	1344	12
46120G80191M40	19G4	26,4	729,6	1560	12
46120G83020M60	2x6	14,2	115,2	327	10
46120G82031M60	3G6	14,9	172,8	394	10
46120G82041M60	4G6	16,2	230,4	497	10
46120G82051M60	5G6	17,9	288	641	10
46120G80071M60	7G6	19,3	403,2	814	10
46120G80101M60	10G6	24	576	1282	10
46120G80121M60	12G6	25,4	691,2	1502	10
46120G80161M60	16G6	28,1	921,6	1964	10
46120G83020M61	2x10	16,3	192	578	8
46120G82031M61	3G10	17,4	288	637	8
46120G82041M61	4G10	19,2	384	777	8
46120G82051M61	5G10	21	480	1040	8
46120G83020M62	2x16	18,9	307,2	746	6
46120G82031M62	3G16	20	460,8	987	6
46120G82041M62	4G16	21,8	614,4	1082	6
46120G83020M63	2x25	22,8	480	1260	4
46120G82031M63	3G25	24,1	720	1460	4
46120G82041M63	4G25	26,7	960	1659	4

Other dimensions and colours available on request.

INDUSTRIAL LOW VOLTAGE CABLES

FG7(O)H2RAR 0.6/1 kV



ELETTROTEK KABEL® FG7OH2RAR

Construction:

Conductor:	flexible red copper conductor Cl.5, acc. to IEC 60228
Insulation:	rubber, type G7
Colour cores:	acc. to DIN VDE 0293-308, HD 308 S2 from 6 cores black cores with consecutive numbers acc. to EN 50334; green-yellow earth-wire from 3 cores
Screen:	red copper braid
Inner sheath:	PVC compound
Armour:	braid of galvanized steel wires
Outer sheath:	grey (RAL 7035), PVC, type Rz

Technical data:

Nominal voltage:	0,6/1 kV
Test voltage:	4 kV
Temperature range:	- 20 °C / + 90 °C
Max short circuit temperature:	+ 250 °C
Min. bending radius:	15 x d

Resistance:



Flame retardant acc. to:
DIN VDE 0482 part 265-2-1
EN 60332-1-2 CEI 20-22II



Corrosiveness of conflagration gases acc. to:
DIN VDE 0482 part 267
EN 50267-2-2
IEC 60754-2 (equivalent DIN VDE 0472 part 813)

Features:

according to IEC 60502-1

EN 60332-1-2 CEI 20-22II comparable to IEC 60332-3-22

INDUSTRIAL LOW VOLTAGE CABLES

FG7(O)H2RAR 0.6/1 kV



ELETTROTEK KABEL® FG7OH2RAR

Part no.	No. of cores x cross section n x mm ²	Outer-Ø ca. mm ± 10%	Cable weight approx. kg/km	AWG no. *)
46130G83020M15	2x1,5	16,1	239	16
46130G82031M15	3G1,5	17,1	260	16
46130G82041M15	4G1,5	17,6	306	16
46130G82051M15	5G1,5	18,7	338	16
46130G80071M15	7G1,5	19,7	388	16
46130G80101M15	10G1,5	23,3	552	16
46130G80121M15	12G1,5	23,8	573	16
46130G80161M15	16G1,5	25,6	722	16
46130G80191M15	19G1,5	26,6	779	16
46130G80241M15	24G1,5	30	948	16
46130G83020M25	2x2,5	16,1	299	14
46130G82031M25	3G2,5	17,1	329	14
46130G82041M25	4G2,5	19,1	387	14
46130G82051M25	5G2,5	20	440	14
46130G83020M40	2x4	18,6	361	12
46130G82031M40	3G4	19,1	414	12
46130G82041M40	4G4	19,5	493	12
46130G82051M40	5G4	21,8	573	12
46130G82031M60	3G6	20,6	488	10
46130G82041M60	4G6	22,1	599	10
46130G82051M60	5G6	23,4	703	10
46130G83020M61	2x10	64,8	567	8
46130G82031M61	3G10	68,4	673	8
46130G82041M61	4G10	24,6	818	8
46130G82051M61	5G10	34,1	997	8
46130G83020M62	2x16	24,1	767	6
46130G82031M62	3G16	25,1	915	6
46130G82041M62	4G16	27,1	1000	6
46130G83020M63	2x25	17,1	1084	4
46130G82031M63	3G25	18,1	1318	4
46130G82041M63	4G25	31,6	1677	4

Other dimensions and colours available on request.

FG7(O)HH2RAR 0.6/1 kV



ELETTROTEK KABEL® FG7OHH2RAR

Construction:

Conductor:	flexible red copper conductor Cl.5, acc. to IEC 60228
Insulation:	rubber HEPR
Colour cores:	acc. to DIN VDE 0293-308, HD 308 S2 from 6 cores black cores with consecutive numbers acc. to EN 50334; green-yellow earth-wire from 3 cores
Screen:	aluminium tape and red copper braid
Inner sheath:	PVC compound
Armour:	braid of galvanized steel wires
Outer sheath:	grey (RAL 7035), PVC, type Rz

Resistance:



Flame retardant acc. to:
DIN VDE 0482 part 265-2-1
EN 60332-1-2 CEI 20-22II



Corrosiveness of conflagration gases acc. to:
DIN VDE 0482 part 267
EN 50267-2-2
IEC 60754-2 (equivalent DIN VDE 0472 part 813)

Technical data:

Nominal voltage:	0,6/1 kV
Test voltage:	4 kV
Temperature range:	- 20 °C / + 90 °C
Max short circuit temperature:	+ 250 °C
Min. bending radius:	15 x d

Features:

according to IEC 60502-1

EN 60332-1-2 CEI 20-22II comparable to IEC 60332-3-22

INDUSTRIAL LOW VOLTAGE CABLES

FG7(O)HH2RAR 0.6/1 kV



ELETTROTEK KABEL® FG7OHH2RAR

Part no.	No. of cores x cross section n x mm ²	Outer-Ø ca. mm ± 10%	Cable weight approx. kg/km	AWG no. *)
46140G83020M15	2x1,5	16,1	245	16
46140G82031M15	3G1,5	17,1	265	16
46140G82041M15	4G1,5	17,6	310	16
46140G82051M15	5G1,5	18,7	340	16
46140G80071M15	7G1,5	19,7	390	16
46140G80101M15	10G1,5	23,3	555	16
46140G80121M15	12G1,5	23,8	575	16
46140G80161M15	16G1,5	25,6	725	16
46140G80191M15	19G1,5	26,6	785	16
46140G80241M15	24G1,5	30	950	16
46140G83020M25	2x2,5	16,1	305	14
46140G82031M25	3G2,5	17,1	335	14
46140G82041M25	4G2,5	19,1	390	14
46140G82051M25	5G2,5	20	445	14
46140G83020M40	2x4	18,6	365	12
46140G82031M40	3G4	19,1	420	12
46140G82041M40	4G4	19,5	495	12
46140G82051M40	5G4	21,8	575	12
46140G82031M60	3G6	20,6	490	10
46140G82041M60	4G6	22,1	600	10
46140G82051M60	5G6	23,4	705	10
46140G83020M61	2x10	64,8	570	8
46140G82031M61	3G10	68,4	675	8
46140G82041M61	4G10	24,6	820	8
46140G82051M61	5G10	34,1	1000	8
46140G83020M62	2x16	24,1	770	6
46140G82031M62	3G16	25,1	920	6
46140G82041M62	4G16	27,1	1005	6
46140G83020M63	2x25	17,1	1090	4
46140G82031M63	3G25	18,1	1320	4
46140G82041M63	4G25	31,6	1680	4

Other dimensions and colours available on request.

INDUSTRIAL LOW VOLTAGE CABLES

GAALFLEX® CONTROL 1000 BH

halogen-free, control cable with coloured cores 0,6/1 kV



GAALFLEX® CONTROL 1000 BH

Construction:

Conductor:	flexible red copper conductor Cl.5, acc. to IEC 60228
Insulation:	halogen-free compound
Colour cores:	acc. to DIN VDE 0293-308, HD 308 S2 from 6 cores black cores with consecutive numbers acc. to EN 50334; green-yellow earth-wire from 3 cores
Wrapping:	filler compound
Outer sheath:	grey (RAL 7035), thermoplastic, halogen-free, type M1

Resistance:



Self-extinguishing and flame retardant acc. to:

DIN VDE 0482 part 265-2-1
EN 50266-2-4
IEC 60332-1-2 CEI 20-22 III
(equivalent IEC 60332-3-24)



Halogen free acc. to:

DIN VDE 0482 part 267
EN 50267-2-1
IEC 60754-1



Corrosiveness of conflagration gases acc. to:

DIN VDE 0482 part 267
EN 50267-2-2
IEC 60754-2

Technical data:

Nominal voltage:	0,6/1 kV
Test voltage:	4 kV
Temperature range:	- 15 °C / + 90 °C
Max short circuit temperature:	+ 250 °C
Min. bending radius	
<i>Fixed laying:</i>	4 x d
<i>Flexible application:</i>	6 x d
tensile stress	
<i>during installation:</i>	50 N/mm ²
<i>static stress:</i>	15 N/mm ²

Features:

CEI 20-13 / 20-22 III (EN 50266) / 20-35 (EN 60332-1)
20-37 (EN 50267) / UNEL TABLES 35382 - 35384

Part no.	No. of cores x cross section n x mm ²	Outer-Ø ca. mm ± 10%	Copper weight kg/km	Cable weight approx. kg/km	AWG no. *)
31260G53020M15	2 x 1,5	10	28,8	127	16
31260G53020M25	2 x 2,5	10,9	48	158	14
31260G53020M40	2 x 4	11,9	76,8	208	12
31260G53020M60	2 x 6	13,1	115,2	258	10
31260G53020M61	2 x 10	15,3	192,0	385	8
31260G53020M62	2 x 16	17,5	307,2	565	6
31260G53020M63	2 x 25	20,3	480	793	4
31260G53020M64	2 x 35	22,4	672	1037	2
31260G53020M65	2 x 50	26,2	960	1447	1
31260G53020M66	2 x 70	30,9	1344	2224	2/0
31260G53020M67	2 x 95	34,2	1824	2848	3/0
31260G53020M68	2 x 120	38,4	2304	3599	4/0
31260G53020M69	2 x 150	42,5	2880	3939	250 MCM

INDUSTRIAL LOW VOLTAGE CABLES

GAALFLEX® CONTROL 1000 BH

halogen-free, control cable with coloured cores 0,6/1 kV



GAALFLEX® CONTROL 1000 BH

Part no.	No. of cores x cross section n x mm ²	Outer-Ø ca. mm ± 10%	Copper weight kg/km	Cable weight approx. kg/km	AWG no. *)
31260G52031M15	3 G 1,5	10,4	43,2	143	16
31260G52031M25	3 G 2,5	11,4	72	183	14
31260G52031M40	3 G 4	12,8	115,2	244	12
31260G52031M60	3 G 6	13,8	172,8	314	10
31260G52031M61	3 G 10	16,9	288	493	8
31260G52031M62	3 G 16	18,2	460,8	678	6
31260G52031M63	3 G 25	21,2	720	977	4
31260G52031M64	3 G 35	23,5	1008	1354	2
31260G52031M65	3 G 50	29,5	1440	1918	1
31260G52031M66	3 G 70	30	2016	2624	2/0
31260G52031M67	3 G 95	34	2736	3418	3/0
31260G52031M68	3 G 120	37,9	3456	4326	4/0
31260G52031M69	3 G 150	42,6	4320	5348	250 MCM
31260G52031M70	3 G 185	47,2	5328	6611	350 MCM
31260G52031M71	3 G 240	53,4	6912,0	8613	450 MCM
31260G52031M72	3 G 300	60,7	8640,0	10700	550 MCM
31260G52041M15	4 G 1,5	10,9	57,6	167	16
31260G52041M25	4 G 2,5	12,3	96,0	217	14
31260G52041M40	4 G 4	13,7	153,6	293	12
31260G52041M60	4 G 6	15	230,5	376	10
31260G52041M61	4 G 10	18	384,0	599	8
31260G52041M62	4 G 16	20,3	614,4	871	6
31260G52041M63	4 G 25	23,5	960,0	1239	4
31260G52035M64	3 x 35 + 1 G 25	26,3	1248,0	1589	2
31260G52035M65	3 x 50 + 1 G 25	30,3	1680,0	2116	1
31260G52035M66	3 x 70 + 1 G 35	35,7	2352,0	2975	2/0
31260G52035M67	3 x 95 + 1 G 50	41,2	3216,0	3971	3/0
31260G52035M68	3 x 120 + 1 G 70	45	4128,0	5219	4/0
31260G52035M69	3 x 150 + 1 G 95	52	5232,0	6511	250 MCM
31260G52035M70	3 x 185 + 1 G 95	56,7	6240,0	7669	350 MCM
31260G52035M71	3 x 240 + 1 G 150	65,6	8352,0	10279	450 MCM
31260G52035M72	3 x 300 + 1 G 150	68	10080,0	10700	550 MCM
31260G52051M15	5 G 1,5	12,1	72,0	197	16
31260G52051M25	5 G 2,5	13,5	120,0	266	14
31260G52051M40	5 G 4	15,2	196,0	361	12
31260G52051M60	5 G 6	16,7	288,0	471	10
31260G52051M61	5 G 10	19,7	480,0	756	8
31260G52051M62	5 G 16	22,5	768,0	1119	6
31260G52051M63	5 G 25	26,5	1200,0	1597	4
31260G52051M64	5 G 35	32,9	1680,0	2160	2
31260G52051M65	5 G 50	38,3	2400,0	3000	1
31260G50071M15	7 G 1,5	13,6	100,8	261	16
31260G50071M25	7 G 2,5	15	168,0	347	14
31260G50071M25	10 G 1,5	15,2	144,0	344	16
31260G50071M25	10 G 2,5	15,0	240,0	463	14
31260G50121M15	12 G 1,5	17,2	172,8	397	16
31260G50121M25	12 G 2,5	17,6	288,0	537	14
31260G50121M25	16 G 1,5	18,5	230,4	535	16
31260G50121M25	16 G 2,5	21,5	384,0	738	14
31260G50191M25	19 G 1,5	18,8	273,6	598	16
31260G50191M25	19 G 2,5	21,6	456,0	831	14
31260G50241M25	24 G 1,5	21,7	324,0	718	16
31260G50241M25	24 G 2,5	24,7	576,0	1029	14

Other dimensions and colours available on request.

INDUSTRIAL LOW VOLTAGE CABLES

FG7(O)MI 0,6/1 kV



ELETTROTEK KABEL® FG7OM1

Construction:

- Conductor:** flexible red copper conductor Cl.5, acc. to IEC 60228
- Insulation:** HEPR, type G7
- Colour cores:** acc. to DIN VDE 0293-308, HD 308 S2 from 6 cores black cores with consecutive numbers acc. to EN 50334; green-yellow earth-wire from 3 cores
- Inner sheath:** not hygroscopic filler
- Outer sheath:** green (RAL 6018), thermoplastic, halogen-free, type M1

Resistance:



Self-extinguishing and flame retardant acc. to:
DIN VDE 0482 part 265-2-1
EN 50266-2-4
IEC 60332-1-2 CEI 20-22 III
(equivalent IEC 60332-3-24)



Halogen free acc. to:
DIN VDE 0482 part 267
EN 50267-2-1
IEC 60754-1



Corrosiveness of conflagration gases acc. to:
DIN VDE 0482 part 267
EN 50267-2-2
IEC 60754-2

Technical data:

- Nominal voltage:** 0,6/1 kV
- Test voltage:** 4 kV
- Temperature range:** - 15 °C / + 90 °C
- Max short circuit temperature:** + 250 °C
- Min. bending radius**
- Power cables:* 4 x d
- Control cables:* 6 x d
- Max. tensile stress:** 50 N/mm²

Features:

CEI 20-13 / 20-22 III (EN 50266) / 20-35 (EN 60332-1)
20-37 (EN 50267) / UNEL TABLES 35382 - 35384

Part no.	No. of cores x cross section n x mm ²	Outer-Ø ca. mm ± 10%	Copper weight kg/km	Cable weight approx. kg/km	AWG no. *)
46150GEL010M62	1x16	9,6	153,6	206	6
46150GEL010M63	1x25	11,5	240	295	4
46150GEL010M64	1x35	12,5	336	359	2
46150GEL010M65	1x50	14,5	480	542	1
46150GEL010M66	1x70	16,4	672	739	2/0
46150GEL010M67	1x95	18	912	964	3/0
46150GEL010M68	1x120	20,3	1152	1189	4/0
46150GEL010M69	1x150	21,6	1440	1484	250 MCM
46150GEL010M70	1x185	24	1776	1780	350 MCM
46150GEL010M71	1x240	27	2304	2319	450 MCM
46150GEL010M72	1x300	29,3	2880	2877	550 MCM
46150GE3020M15	2x1,5	10	28,8	127	16
46150GE3020M25	2x2,5	11	48	158	14
46150GE3020M40	2x4	12,2	76,8	208	12
46150GE3020M60	2x6	13,1	115,2	258	10
46150GE3020M61	2x10	15,2	192	385	8
46150GE3020M62	2x16	17,4	307,2	565	6
46150GE3020M63	2x25	20,3	480	793	4
46150GE3020M64	2x35	22,3	672	1037	2
46150GE3020M65	2x50	26,2	960	1447	1
46150GE3020M66	2x70	30,8	1344	2224	2/0
46150GE3020M67	2x95	34,2	1824	2848	3/0
46150GE3020M68	2x120	38,4	2304	3599	4/0
46150GE3020M69	2x150	42,4	2880	3939	250 MCM

INDUSTRIAL LOW VOLTAGE CABLES

FG7(O)MI 0,6/I kV



Part no.	No. of cores x cross section n x mm ²	Outer-Ø ca. mm ± 10%	Copper weight kg/km	Cable weight approx. kg/km	AWG no. *)
46150GE2031M15	3G1,5	10,4	43,2	143	16
46150GE2031M25	3G2,5	11,4	72	183	14
46150GE2031M40	3G4	12,8	115,2	244	12
46150GE2031M60	3G6	13,8	172,8	314	10
46150GE2031M61	3G10	16,9	288	493	8
46150GE2031M62	3G16	18,2	460,8	678	6
46150GE2031M63	3G25	21,2	720	977	4
46150GE2031M64	3G35	23,5	1008	1354	2
46150GE2031M65	3G50	30	1440	1918	1
46150GE2031M66	3G70	34	2016	2624	2/0
46150GE2031M67	3G95	37,8	2736	3418	3/0
46150GE2031M68	3G120	42,6	3456	4326	4/0
46150GE2031M69	3G150	47,1	4320	5348	250 MCM
46150GE2031M70	3G185	53,3	5328	6611	350 MCM
46150GE2031M71	3G240	60,7	6912	8613	450 MCM
46150GE2041M15	4G1,5	11,2	57,6	167	16
46150GE2041M25	4G2,5	12,3	96	221	14
46150GE2041M40	4G4	13,7	153,6	293	12
46150GE2041M60	4G6	14,9	230,4	387	10
46150GE2041M61	4G10	18	384	599	8
46150GE2041M62	4G16	20,3	614,4	871	6
46150GE2041M63	4G25	23,5	960	1239	4
46150GE2035M64	3x35+25	26,3	1248	1589	2
46150GE2035M65	3x50+25	30,3	1680	2116	1
46150GE2035M66	3x70+35	35,7	2352	2975	2/0
46150GE2035M67	3x95+50	41	3216	3971	3/0
46150GE2035M68	3x120+70	45	4128	5219	4/0
46150GE2035M69	3x150+95	52	5232	6511	250 MCM
46150GE2035M70	3x185+95	56,72	6240	7669	350 MCM
46150GE2035M71	3x240+150	65,5	8352	10279	450 MCM
46150GE2051M15	5G1,5	12,1	72	197	16
46150GE2051M25	5G2,5	13,5	120	262	14
46150GE2051M40	5G4	15,2	192	361	12
46150GE2051M60	5G6	16,6	288	476	10
46150GE2051M61	5G10	19,6	480	756	8
46150GE2051M62	5G16	22,5	768	1119	6
46150GE2051M63	5G25	26,4	1200	1597	4
46150GE0071M15	7G1,5	13,6	100,8	261	16
46150GE0071M25	7G2,5	14,9	168	344	14
46150GE0101M15	10G1,5	15,6	144	344	16
46150GE0101M25	10G2,5	17,2	240	463	14
46150GE0121M15	12G1,5	17	172,8	393	16
46150GE0121M25	12G2,5	17,6	288	537	14
46150GE0161M15	16G1,5	18,5	230,4	535	16
46150GE0161M25	16G2,5	21,5	384	738	14
46150GE0191M15	19G1,5	18,8	273,6	598	16
46150GE0191M25	19G2,5	21,6	456	831	14
46150GE0241M15	24G1,5	21,7	345,6	718	16
46150GE0241M25	24G2,5	24,7	576	1029	14

Other dimensions and colours available on request.

INDUSTRIAL LOW VOLTAGE CABLES

FG7(O)H2MI 0,6/1kV



ELETTROTEK KABEL® FG7OH2MI

Construction:

- Conductor:** flexible red copper conductor Cl.5, acc. to IEC 60228
- Insulation:** rubber, type G7
- Colour cores:** acc. to DIN VDE 0293-308, HD 308 S2 from 6 cores black cores with consecutive numbers acc. to EN 50334; green-yellow earth-wire from 3 cores
- Inner sheath:** halogen free compound, type M1 and not hygroscopic filler
- Screen:** red copper braid
- Outer sheath:** green (RAL 6018), thermoplastic, halogen-free, type M1

Resistance:



Self-extinguishing and flame retardant acc. to:

DIN VDE 0482 part 265-2-1
EN 50266-2-4
IEC 60332-1-2 CEI 20-22 III
(equivalent IEC 60332-3-24)



Halogen free acc. to:

DIN VDE 0482 part 267
EN 50267-2-1
IEC 60754-1



Corrosiveness of conflagration gases acc. to:

DIN VDE 0482 part 267
EN 50267-2-2
IEC 60754-2

Technical data:

- Nominal voltage:** 0,6/1 kV
- Test voltage:** 4 kV
- Temperature range:** - 15 °C / + 90 °C
- Max short circuit temperature:** + 250 °C
- Min. bending radius:** 8 x d
- Max. tensile stress:** 50 N/mm²

Features:

according to IEC 60502-1

Part no.	No. of cores x cross section n x mm ²	Outer-Ø ca. mm ± 10%	Cable weight approx. kg/km	AWG no. *)
46160GE3020M15	2x1,5	12,7	241	16
46160GE3020M25	2x2,5	13,7	280	14
46160GE3020M40	2x4	14,9	336	12
46160GE3020M60	2x6	16,1	395	10
46160GE3020M61	2x10	18,2	567	8
46160GE3020M62	2x16	20,4	738	6
46160GE3020M63	2x25	24	1107	4
46160GE3020M64	2x35	26,6	1403	2
46160GE3020M65	2x50	30,5	1830	1
46160GE3020M66	2x70	34,3	2571	2/0
46160GE3020M67	2x95	38,6	3143	3/0
46160GE3020M68	2x120	43	4316	4/0
46160GE3020M69	2x150	47,5	5547	250 MCM
46160GE2031M15	3G1,5	13,3	262	16
46160GE2031M25	3G2,5	14,3	316	14
46160GE2031M40	3G4	15,6	380	12
46160GE2031M60	3G6	16,9	456	10
46160GE2031M61	3G10	19,2	675	8
46160GE2031M62	3G16	21,5	939	6
46160GE2031M63	3G25	25,4	1346	4
46160GE2031M64	3G35	28,3	1744	2
46160GE2031M65	3G50	32,4	2262	1
46160GE2031M66	3G70	36,8	3188	2/0
46160GE2031M67	3G95	41,2	4309	3/0
46160GE2031M68	3G120	45,8	5635	4/0
46160GE2031M69	3G150	50,9	6921	250 MCM
46160GE2031M70	3G185	56,6	8079	350 MCM
46160GE2031M71	3G240	63,3	10639	450 MCM

INDUSTRIAL LOW VOLTAGE CABLES

FG7(O)H2MI 0,6/1kV



Part no.	No. of cores x cross section n x mm ²	Outer-Ø ca. mm ± 10%	Cable weight approx. kg/km	AWG no. *)
46160GE2041M15	4G1,5	14,1	298	16
46160GE2041M25	4G2,5	15,3	357	14
46160GE2041M40	4G4	16,7	438	12
46160GE2041M60	4G6	18,4	535	10
46160GE2041M61	4G10	20,8	802	8
46160GE2041M62	4G16	23,4	1164	6
46160GE2041M63	4G25	27,7	1664	4
46160GE2035M64	3x35+25	30,4	2038	2
46160GE2035M65	3x50+25	33,6	2606	1
46160GE2035M66	3x70+35	38,2	3540	2/0
46160GE2035M67	3x95+50	43,4	4818	3/0
46160GE2035M68	3x120+70	48,4	6358	4/0
46160GE2035M69	3x150+95	53,9	7852	250 MCM
46160GE2035M70	3x185+95	58,8	9066	350 MCM
46160GE2035M71	3x240+150	66,9	12078	450 MCM
46160GE2051M15	5G1,5	15,1	351	16
46160GE2051M25	5G2,5	16,4	424	14
46160GE2051M40	5G4	18,2	527	12
46160GE2051M60	5G6	19,8	653	10
46160GE2051M61	5G10	22,4	1027	8
46160GE2051M62	5G16	25,4	1415	6
46160GE2051M63	5G25	30,5	2022	4
46160GE0071M15	7G1,5	16,1	399	16
46160GE0071M25	7G2,5	17,8	496	14
46160GE0101M15	10G1,5	19,7	503	16
46160GE0101M25	10G2,5	21,6	644	14
46160GE0121M15	12G1,5	20,2	574	16
46160GE0121M25	12G2,5	22,2	732	14
46160GE0161M15	16G1,5	22	690	16
46160GE0161M25	16G2,5	24,3	950	14
46160GE0191M15	19G1,5	23	813	16
46160GE0191M25	19G2,5	25,4	1056	14
46160GE0241M15	24G1,5	26,4	972	16
46160GE0241M25	24G2,5	29,3	1218	14

Other dimensions and colours available on request.

INDUSTRIAL LOW VOLTAGE CABLES

FG7(O)AMI 0,6/1kV



ELETTROTEK KABEL® FG7OAM1

Construction:

Conductor:	flexible red copper conductor Cl.5, acc. to IEC 60228
Insulation:	rubber, type G7
Colour cores:	acc. to DIN VDE 0293-308, HD 308 S2 from 6 cores black cores with consecutive numbers acc. to EN 50334; green-yellow earth-wire from 3 cores
Inner sheath:	thermoplastic, halogen free compound
Armour:	braid of galvanized steel wires
Outer sheath:	green (RAL 6018), thermoplastic, halogen-free, type M1

Resistance:



Self-extinguishing and flame retardant acc. to:
DIN VDE 0482 part 265-2-1
EN 50266-2-4
IEC 60332-1-2 CEI 20-22 III
(equivalent IEC 60332-3-24)



Halogen free acc. to:
DIN VDE 0482 part 267
EN 50267-2-1
IEC 60754-1



Corrosiveness of conflagration gases acc. to:
DIN VDE 0482 part 267
EN 50267-2-2
IEC 60754-2

Technical data:

Nominal voltage:	0,6/1 kV
Test voltage:	4 kV
Temperature range:	- 15 °C / + 90 °C
Max short circuit temperature:	+ 250 °C
Min. bending radius:	14 x d
Max. tensile stress:	50 N/mm ²

Features:

according to IEC 60502-1

Part no.	No. of cores x cross section n x mm ²	Outer-Ø ca. mm ± 10%	Copper weight kg/km	Cable weight approx. kg/km	AWG no. *)
46170GE3020M15	2x1,5	12,7	28,8	258	16
46170GE3020M25	2x2,5	13,7	48	302	14
46170GE3020M40	2x4	14,9	76,8	359	12
46170GE3020M60	2x6	16,1	115,2	424	10
46170GE3020M61	2x10	18,2	192	605	8
46170GE3020M62	2x16	20,4	307,2	783	6
46170GE3020M63	2x25	24	480	1170	4
46170GE3020M64	2x35	26,6	672	1450	2
46170GE3020M65	2x50	30,5	960	1900	1
46170GE3020M66	2x70	34,3	1344	2735	2/0
46170GE3020M67	2x95	38,6	1824	3320	3/0
46170GE3020M68	2x120	43	2304	4125	4/0
46170GE3020M69	2x150	47,5	2880	5780	250 MCM
46170GE2031M15	3G1,5	13,3	43,2	280	16
46170GE2031M25	3G2,5	14,3	72	335	14
46170GE2031M40	3G4	15,6	115,2	405	12
46170GE2031M60	3G6	16,9	172,8	490	10
46170GE2031M61	3G10	19,2	288	715	8
46170GE2031M62	3G16	21,5	460,8	990	6
46170GE2031M63	3G25	25,4	720	1410	4
46170GE2031M64	3G35	28,3	1008	1810	2
46170GE2031M65	3G50	32,4	1440	2350	1
46170GE2031M66	3G70	36,8	2016	3370	2/0
46170GE2031M67	3G95	41,2	2736	4520	3/0
46170GE2031M68	3G120	45,8	3456	5880	4/0
46170GE2031M69	3G150	50,9	4320	7200	250 MCM
46170GE2031M70	3G185	56,6	5328	8350	350 MCM
46170GE2031M71	3G240	63,3	6912	10990	450 MCM
46170GE2031M72	3G300	69,5	8640	13740	550 MCM

INDUSTRIAL LOW VOLTAGE CABLES

FG7(O)AMI 0,6/1kV



Part no.	No. of cores x cross section n x mm ²	Outer-Ø ca. mm ± 10%	Copper weight kg/km	Cable weight approx. kg/km	AWG no. *)
46170GE2041M15	4G1,5	14,1	57,6	320	16
46170GE2041M25	4G2,5	15,3	96	385	14
46170GE2041M40	4G4	16,7	153,6	470	12
46170GE2041M60	4G6	18,4	230,4	575	10
46170GE2041M61	4G10	20,8	384	850	8
46170GE2041M62	4G16	23,4	614,4	1220	6
46170GE2041M63	4G25	27,7	960	1730	4
46170GE2035M64	3x35+25	30,4	1248	2110	2
46170GE2035M65	3x50+25	33,6	1680	2700	1
46170GE2035M66	3x70+35	38,2	2352	3715	2/0
46170GE2035M67	3x95+50	43,4	3216	5020	3/0
46170GE2035M68	3x120+70	48,4	4128	6600	4/0
46170GE2035M69	3x150+95	53,9	5232	8110	250 MCM
46170GE2035M70	3x185+95	58,8	6240	9350	350 MCM
46170GE2035M71	3x240+150	66,9	8352	12400	450 MCM
46170GE2035M72	3x300+150	72,2	10080	14970	550 MCM
46170GE2051M15	5G1,5	15,1	72	375	16
46170GE2051M25	5G2,5	16,4	120	460	14
46170GE2051M40	5G4	18,2	192	570	12
46170GE2051M60	5G6	19,8	288	700	10
46170GE2051M61	5G10	22,4	480	1080	8
46170GE2051M62	5G16	25,4	768	1480	6
46170GE2051M63	5G25	30,5	1200	2100	4
46170GE2051M64	5G35	34	1680	2950	2
46170GE2051M65	5G50	39,4	2400	4200	1
46170GE0071M15	7G1,5	16,1	100,8	430	16
46170GE0071M25	7G2,5	17,8	168	540	14
46170GE0101M15	10G1,5	19,7	144	470	16
46170GE0101M25	10G2,5	21,6	240	685	14
46170GE0121M15	12G1,5	20,2	172,8	615	16
46170GE0121M25	12G2,5	22,2	288	785	14
46170GE0161M15	16G1,5	22	230,4	740	16
46170GE0161M25	16G2,5	24,3	384	1005	14
46170GE0191M15	19G1,5	23	273,6	870	16
46170GE0191M25	19G2,5	25,4	456	1120	14
46170GE0241M15	24G1,5	26,4	345,6	1035	16
46170GE0241M25	24G2,5	29,3	576	1350	14

Other dimensions and colours available on request.

INDUSTRIAL LOW VOLTAGE CABLES

NYJ-J/O

power cable 0,6/1 kV



ELETTROTEK KABEL® NYJ-J/O

Construction:

Conductor:	solid or stranded red copper conductor Cl.1 or 2, acc. to IEC 60228 DIN VDE 0295
Insulation:	PVC, type DIV4
Colour cores:	acc. to DIN VDE 0293-308, HD 308 S2 from 6 cores black cores with consecutive numbers acc. to EN 50334; green-yellow earth-wire from 3 cores
Stranding:	cores stranded concentrically
Outer sheath:	black (RAL 9005), PVC, type DMV5

Resistance:



Flame retardant acc. to:
DIN VDE 0482 part 265-2-1
EN 50265-2-1
IEC 60332-1

Technical data:

Nominal voltage:	0,6/1 kV
Test voltage:	4 kV
Highest permissible voltage:	
<i>Direct current system:</i>	1,8 Kv
<i>Alternating current system single-phase system:</i>	1,4 Kv
<i>Both conductor insulated, single-phase system:</i>	0,7 Kv
<i>One conductor earthed, three phase system:</i>	1,2 Kv
<i>With concentric conductor and a cross-section of 240 mm² and above:</i>	3,6 Kv
Temperature range	
<i>Fixed laying:</i>	- 40 °C / + 70 °C
<i>Flexible application:</i>	- 5 °C / + 50 °C
Max short circuit temperature:	+ 160 °C
Min. bending radius	
<i>Single core:</i>	12 x d
<i>Multi cores:</i>	15 x d

Features:

according to IEC 60502-1

Ozone resistance

UV resistance



re: circular solid conductor



rm: circular stranded conductor



sm: sector-shaped stranded conductor



se: sector-shaped solid conductor

INDUSTRIAL LOW VOLTAGE CABLES

NYJ-J/O

power cable 0,6/1 kV



ELETTROTEK KABEL® NYJ-J/O

j - type Part no.	O - type Part no.	No. of cores x cross section n x mm ²	Outer-Ø ca. mm ± 10%	Copper weight kg/km	Cable weight approx. kg/km	AWG no. *)
46180G7P011M40	46180G7L010M40	1 x 4 re	9,2	38	120	12
46180G7P011M60	46180G7L010M60	1 x 6 re	9,7	58	140	10
46180G7P011M61	46180G7L010M61	1 x 10 re	10,3	96	190	8
46180G7P011M62	46180G7L010M62	1 x 16 re	11,2	154	260	6
46180G7P011M63	46180G7L010M63	1 x 25 rm	12,4	240	370	4
46180G7P011M64	46180G7L010M64	1 x 35 rm	13,4	336	480	2
46180G7P011M65	46180G7L010M65	1 x 50 rm	15,3	480	630	1
46180G7P011M66	46180G7L010M66	1 x 70 rm	16,7	672	820	2/0
46180G7P011M67	46180G7L010M67	1 x 95 rm	19,3	912	1120	3/0
46180G7P011M68	46180G7L010M68	1 x 120 rm	20,8	1152	1375	4/0
46180G7P011M69	46180G7L010M69	1 x 150 rm	22,8	1440	1690	250 MCM
46180G7P011M70	46180G7L010M70	1 x 185 rm	25,4	1776	2070	350 MCM
46180G7P011M71	46180G7L010M71	1 x 240 rm	28,4	2304	2650	450 MCM
46180G7P011M72	46180G7L010M72	1 x 300 rm	30,5	2880	3210	550 MCM
46180G7P011M73	46180G7L010M73	1 x 400 rm	34,4	3840	4160	750 MCM
46180G7P011M74	46180G7L010M74	1 x 500 rm	38,2	4800	5210	1000 MCM
46180G7P011M75	46180G7L010M75	1 x 630 rm	43,5	6048	6670	1250 MCM
	46180G73020M15	2 x 1,5 re	11,4	29	190	16
	46180G73020M25	2 x 2,5 re	12,3	48	230	14
	46180G73020M40	2 x 4 re	14,5	77	310	12
	46180G73020M60	2 x 6 re	15,3	115	390	10
	46180G73020M61	2 x 10 re	16,8	192	520	8
	46180G73020M62	2 x 16 re	18,7	307	680	6
	46180G73020M63	2 x 25 rm	23,5	480	970	4
46180G72031M15	46180G73030M15	3 x 1,5 re	11,8	43	210	16
46180G72031M25	46180G73030M25	3 x 2,5 re	12,7	72	260	14
46180G72031M40	46180G73030M40	3 x 4 re	14,3	115	350	12
46180G72031M60	46180G73030M60	3 x 6 re	15,2	173	440	10
46180G72031M61	46180G73030M61	3 x 10 re	17,3	288	600	8
46180G72031M62	46180G73030M62	3 x 16 re	19,2	461	830	6
46180G72031M63	46180G73030M63	3 x 25 rm	24,5	720	1340	4
46180G72031M64	46180G73030M64	3 x 35 sm	25,3	1008	1460	2
46180G72031M65	46180G73030M65	3 x 50 sm	26,8	1440	1860	1
46180G72031M66	46180G73030M66	3 x 70 sm	30,8	2016	2460	2/0
46180G72031M67	46180G73030M67	3x95 sm	34,9	2763	3320	3/0
46180G72031M68	46180G73030M68	3x120 sm	37,4	3456	4120	4/0
46180G72031M69	46180G73030M69	3x150 sm	40,3	4320	4910	250 MCM
46180G72031M70	46180G73030M70	3x185 sm	46,4	5328	6520	350 MCM
46180G72031M71	46180G73030M71	3x240 sm	51,4	6912	8315	450 MCM

INDUSTRIAL LOW VOLTAGE CABLES

NYJ-J/O

power cable 0,6/1 kV



ELETTROTEK KABEL® NYJ-J/O

j - type Part no.	O - type Part no.	No. of cores x cross section n x mm ²	Outer-Ø ca.mm ± 10%	Copper weight kg/km	Cable weight approx. kg/km	AWG no.®)
46180G72035M63	46180G73035M63	3X25/16 rm/re	24,5	874	1530	4
46180G72035M64	46180G73035M64	3x35/16 sm/re	26	1162	1750	2
46180G72035M65	46180G73035M65	3x50/25 sm/rm	29	1680	2350	1
46180G72035M66	46180G73035M66	3x70/35 sm/rm	32	2352	2850	2/0
46180G72035M67	46180G73035M67	3x95/50 sm	38	3216	3850	3/0
46180G72035M68	46180G73035M68	3x120/70 sm	41	4128	4780	4/0
46180G72035M69	46180G73035M69	3x150/70 sm	46	4992	5800	250 MCM
46180G72035M70	46180G73035M70	3x185/95 sm	51	6240	7600	350 MCM
46180G72035M71	46180G73035M71	3x240/120 sm	58	8064	9800	450 MCM
46180G72035M72	46180G73035M72	3x300/150 sm	64	10080	11500	550 MCM
46180G72041M15	46180G73040M15	4x1,5 re	12	58	230	16
46180G72041M25	46180G73040M25	4x2,5 re	13,5	96	300	14
46180G72041M40	46180G73040M40	4x4 re	15	154	410	12
46180G72041M60	46180G73040M60	4x6 re	16,5	230	520	10
46180G72041M61	46180G73040M61	4x10 re	18,5	384	730	8
46180G72041M62	46180G73040M62	4x16 re	21,5	614	1045	6
46180G72041M63	46180G73040M63	4x25 rm	26	960	1640	4
46180G72041M64	46180G73040M64	4x35 sm	27,5	1344	1760	2
46180G72041M65	46180G73040M65	4x50 sm	30	1920	2350	1
46180G72041M66	46180G73040M66	4x70 sm	34	2688	3100	2/0
46180G72041M67	46180G73040M67	4x95 sm	39	3648	4250	3/0
46180G72041M68	46180G73040M68	4x120 sm	42,5	4608	5300	4/0
46180G72041M69	46180G73040M69	4x150 sm	47,5	5760	6400	250 MCM
46180G72041M70	46180G73040M70	4x185 sm	52	7104	8500	350 MCM
46180G72041M71	46180G73040M71	4x240 sm	58	9216	11000	450 MCM
46180G72051M15	46180G73050M15	5x1,5 re	13	72	270	16
46180G72051M25	46180G73050M25	5x2,5 re	14,5	120	360	14
46180G72051M40	46180G73050M40	5x4 re	16,5	192	490	12
46180G72051M60	46180G73050M60	5x6 re	18	288	600	10
46180G72051M61	46180G73050M61	5x10 re	20	480	890	8

Other dimensions and colours available on request.

INDUSTRIAL LOW VOLTAGE CABLES

(N)AYY-J/O

Aluminium power cable 0,6/1 kV



ELETTROTEK KABEL® NAYY-J/O

Construction:

Conductor:	solid or stranded plain aluminium conductor Cl.1 or 2, acc. to IEC 60228 DIN VDE 0295
Insulation:	PVC, type DIV4
Colour cores:	acc. to DIN VDE 0293-308, HD 308 S2 from 6 cores black cores with consecutive numbers acc. to EN 50334; green-yellow earth-wire from 3 cores
Stranding:	cores stranded concentrically
Outer sheath:	black (RAL 9005), PVC, type DMV5

Technical data:

Nominal voltage:	0,6/1 kV
Test voltage:	4 kV
Highest permissible voltage:	
<i>Direct current system:</i>	1,8 Kv
<i>Alternating current system single-phase system:</i>	1,4 Kv
<i>Both conductor insulated, single-phase system:</i>	0,7 Kv
<i>One conductor earthed, three phase system:</i>	1,2 Kv
<i>With concentric conductor and a cross-section of 240 mm² and above:</i>	3,6 Kv
Temperature range:	- 5 °C /+ 70 °C
Min. bending radius:	12 x d
Max. tensile stress:	50 N/mm ²

Resistance:



Flame retardant acc. to:
DIN VDE 0482 part 265-2-1
EN 50265-2-1
IEC 60332-1

Features:

	re: circular solid conductor
	rm: circular stranded conductor
	sm: sector-shaped stranded conductor
	se: sector-shaped solid conductor

Applications:

Power cables for energy supply are installed in open air, in underground, in water, indoors and in cable ducts, power station, for industry and distribution boards as well as in subscriber networks, where mechanical damages are not to be expected.

INDUSTRIAL LOW VOLTAGE CABLES

(N)AYY-J/O

Aluminium power cable 0,6/1 kV



ELETTROTEK KABEL® NAYY-J/O

STRANDED VERSION

j - type Part no.	O - type Part no.	No. of cores x cross section n x mm ²	Outer-Ø ca. mm ± 10%	Copper weight kg/km	Cable weight approx. kg/km	AWG no. *)
46190G7P011M62	46190G7L010M62	1x16 re	11	46,5	145	6
46190G7P011M63	46190G7L010M63	1x25 rm	12	72,5	195	4
46190G7P011M64	46190G7L010M64	1x35 rm	13	101,5	255	2
46190G7P011M65	46190G7L010M65	1x50 rm	15	145	298	1
46190G7P011M66	46190G7L010M66	1x70 rm	16,5	205	383	2/0
46190G7P011M67	46190G7L010M67	1x95 rm	19	275	490	3/0
46190G7P011M68	46190G7L010M68	1x120 rm	20,5	348	575	4/0
46190G7P011M69	46190G7L010M69	1x150 rm	22,5	435	695	250 MCM
46190G7P011M70	46190G7L010M70	1x185 rm	25	536	845	350 MCM
46190G7P011M71	46190G7L010M71	1x240 rm	28	969	1100	450 MCM
46190G7P011M72	46190G7L010M72	1x300 rm	30	870	1379	550 MCM
46190G7P011M73	46190G7L010M73	1x400 rm	34	1160	1615	750 MCM
46190G7P011M74	46190G7L010M74	1x500 rm	38	1450	2015	950 MCM
46190G7P011M75	46190G7L010M75	1x630 rm	43	1827	2472	1200 MCM
	46190G73020M62	2x16 re	18,5	93	470	6
46190G72041M62	46190G73040M62	4x16 rm	21,5	186	750	6
46190G72041M63	46190G73040M63	4x25 sm	26,5	290	950	4
46190G72041M64	46190G73040M64	4x35 sm	27,5	406	1120	2
46190G72041M65	46190G73040M65	4x50 sm	30	580	1151	1
46190G72041M66	46190G73040M66	4x70 sm	34	812	1549	2/0
46190G72041M67	46190G73040M67	4x95 sm	39	1102	2030	3/0
46190G72041M68	46190G73040M68	4x120 sm	42,5	1392	2400	4/0
46190G72041M69	46190G73040M69	4x150 sm	47,5	1740	3030	250 MCM
46190G72041M70	46190G73040M70	4x185 sm	52	2146	3650	350 MCM
46190G72041M71	46190G73040M71	4x240 re	58	2784	4800	450 MCM

SOLID VERSION

j - type Part no.	O - type Part no.	No. of cores x cross section n x mm ²	Outer-Ø ca. mm ± 10%	Copper weight kg/km	Cable weight approx. kg/km	AWG no. *)
46191G72041M62	46191G73040M62	4x16 se	23	186,0	750,0	6
46191G72041M63	46191G73040M63	4x25 se	26	290,0	950,0	4
46191G72041M64	46191G73040M64	4x35 se	28,5	406,0	1120,0	2
46191G72041M65	46191G73040M65	4x50 se	30	580,0	1151,0	1
46191G72041M66	46191G73040M66	4x70 se	35	812,0	1549,0	2/0
46191G72041M67	46191G73040M67	4x95 se	39,5	1102,0	2030,0	3/0
46191G72041M68	46191G73040M68	4x120 se	44	1392,0	2400,0	4/0
46191G72041M69	46191G73040M69	4x150 se	46	1740,0	3030,0	250 MCM
46191G72041M70	46191G73040M70	4x185 se	51	2146,0	3650,0	350 MCM
46191G72041M71	46191G73040M71	4x240 se	56	2784,0	4800,0	450 MCM

Other dimensions and colours available on request.

INDUSTRIAL LOW VOLTAGE CABLES

NYCY

Power cable with concentric copper conductor; 0,6/1 kV



ELETTROTEK KABEL® NYCY



Construction:

Conductor:	solid red copper conductor Cl.1, acc. to IEC 60228 DIN VDE 0295
Insulation:	PVC, type DIV4
Colour cores:	acc. to DIN VDE 0293-308, HD 308 S2 from 6 cores black cores with consecutive numbers acc. to EN 50334; green-yellow earth-wire from 3 cores
Stranding:	cores stranded concentrically
Inner sheath:	filler compound
Screen:	red copper wires + red copper tape
Outer sheath:	black (RAL 9005), PVC, type DMV5

Resistance:



Flame retardant acc. to:
DIN VDE 0482 part 265-2-1
EN 50265-2-1
IEC 60332-1

Technical data:

Nominal voltage:	0,6/1 kV
Test voltage:	4 kV
Highest permissible voltage:	
<i>Direct current system:</i>	1,8 Kv
<i>Alternating current system single-phase system:</i>	1,4 Kv
<i>Both conductor insulated, single-phase system:</i>	0,7 Kv
<i>One conductor earthed, three phase system:</i>	1,2 Kv
<i>With concentric condtor and a cross-section of 240 mm² and above:</i>	3,6 Kv
Temperature range	
<i>Fixed laying:</i>	- 40 °C / + 70 °C
<i>Flexible application:</i>	- 5 °C / + 50 °C
Max short circuit temperature:	+ 160 °C
Min. bending radius	
<i>Single core:</i>	12 x d
<i>Multi cores:</i>	15 x d
Max. tensile stress	50 N/mm ²

Features:

according to DIN VDE 0276 part 603.1, HD 603 S1 and IEC 60502-1

7 cores and above cc. to DIN VDE 0276 part 627, HD 627 S1 and IEC 6050

UV resistance

Applications:

Power cables for energy supply are installed in open air, in underground, in water, indoors and in cable ducts, power station, for industry and distribution boards as well as in subscriber networks, where mechanical damages are not to be expected.

INDUSTRIAL LOW VOLTAGE CABLES

NYCY

Power cable with concentric copper conductor; 0.6/1 kV



ELETTROTEK KABEL® NYCY



Part no.	No. of cores x cross section n x mm ²	Outer-Ø ca. mm ± 10%	Copper weight kg/km	Cable weight approx. kg/km	AWG no. *)
46200G7L010M61	1 x 10 / 10	11	216	280	8
46200G7L010M62	1 x 16 / 16	12	336	440	6
46200G73020M15	2 x 1,5 / 1,5	13	52	205	16
46200G73020M25	2 x 2,5 / 2,5	13,5	80	270	14
46200G73020M40	2 x 4 / 4	15,5	123	360	12
46200G73020M60	2 x 6 / 6	17	182	435	10
46200G73020M61	2 x 10 / 10	19,5	312	590	8
46200G73020M16	2 x 16 / 16	20,5	489	820	6
46200G73030M15	3 X 1,5 / 1,5	13,5	66	225	16
46200G73030M25	3 X 2,5 / 2,5	14,5	104	290	14
46200G73030M40	3 X 4 / 4	16,5	161	400	12
46200G73030M60	3 X 6 / 6	17,5	240	510	10
46200G73030M61	3 X 10 / 10	20	408	850	8
46200G73030M62	3 X 16 / 16	23	643	1080	6
46200G73040M15	4 X 1,5 / 1,5	14,5	81	260	16
46200G73040M25	4 X 2,5 / 2,5	15,5	128	350	14
46200G73040M40	4 X 4 / 4	17	200	470	12
46200G73040M60	4 X 6 / 6	18,5	297	590	10
46200G73040M61	4 X 10 / 10	21	504	900	8
46200G73040M62	4 X 16 / 16	23	796	1250	6
46200G73050M15	5 X 1,5 / 1,5	15	95	330	16
46200G73050M25	5 X 2,5 / 2,5	16	152	400	14
46200G73050M40	5 X 4 / 4	19	238	560	12
46200G73050M60	5 X 6 / 6	21	355	710	10
46200G73050M61	5 X 10 / 10	23	600	1000	8
46200G71070M15	7 X 1,5 / 1,5	15	124	320	16
46200G71070M40	7 X 4 / 4	21	315	670	12
46200G71070M60	7 X 6 / 6	24	470	790	10
46201G71070M15	7 X 1,5 / 2,5	16	133	350	16
46200G71080M15	8 X 1,5 / 1,5	17	138	380	16
46201G71080M15	8 X 1,5 / 2,5	17	147	400	16
46200G71100M15	10 X 1,5 / 2,5	19	176	440	16
46200G71120M15	12 X 1,5 / 2,5	20	205	500	16
46200G71140M15	14 X 1,5 / 2,5	20,5	234	540	16
46200G71160M15	16 X 1,5 / 4	22	276	600	16
46200G71190M15	19 X 1,5 / 4	23	320	690	16
46200G71210M15	21 X 1,5 / 6	24	369	810	16
46200G71240M15	24 X 1,5 / 6	26	413	860	16
46200G71300M15	30 X 1,5 / 6	27	499	1230	16
46200G71400M15	40 X 1,5 / 10	30	696	1590	16
46200G71520M15	52 X 1,5 / 10	32	869	1820	16
46200G71610M15	61 X 1,5 / 10	33	998	2000	16
46200G71070M25	7 X 2,5 / 2,5	17,5	200	450	14
46200G71080M25	8 X 2,5 / 2,5	18	224	510	14
46200G71100M25	10 X 2,5 / 4	20,5	286	600	14
46200G71120M25	12 X 2,5 / 4	21	334	660	14
46200G71140M25	14 X 2,5 / 4	22	382	760	14
46201G71140M25	14 X 2,5 / 6	22,5	403	800	14
46200G71160M25	16 X 2,5 / 6	23	451	910	14
46200G71190M25	19 X 2,5 / 6	23,5	523	950	14
46200G71210M25	21 X 2,5 / 10	26	571	1100	14
46200G71240M25	24 X 2,5 / 10	28	696	1300	14
46200G71300M25	30 X 2,5 / 10	30	840	1610	14
46200G71400M25	40 X 2,5 / 10	35	1080	2100	14
46200G71520M25	52 X 2,5 / 10	38	1368	2500	14
46200G71610M25	61 X 2,5 / 10	40	1584	2850	14

Other dimensions and colours available on request.

GAALFLEX® VFD NYCWY

Power cable with concentric copper conductor, connection to frequency converters, 0,6/1 kV



ELETTROTEK KABEL® GAALFLEX® VFD NYCWY

Construction:

Conductor:	solid or stranded red copper conductor Cl. 1 or 2, acc. to IEC 60228, DIN VDE 0295 10-16 mm ² - round solid cores 25-240 mm ² - stranded conductor
Insulation:	PVC, type DIV4
Colour cores:	acc. to DIN VDE 0293-308, HD 308 S2
Stranding:	cores stranded concentrically
Inner sheath:	filler compound
Screen:	concentric conductor of corrugated copper wires + copper tape
Outer sheath:	black (RAL 9005), PVC, type DMV5

Resistance:



Flame retardant acc. to:
DIN VDE 0482 part 265-2-1
EN 50265-2-1
IEC 60332-1

Technical data:

Nominal voltage:	0,6/1 kV
Test voltage:	4 kV
Highest permissible voltage:	
<i>Direct current system:</i>	1,8 kV
<i>Alternating current system single-phase system:</i>	1,4 kV
<i>Both conductor insulated, single-phase system:</i>	0,7 kV
<i>One conductor earthed, three phase system:</i>	1,2 kV
<i>With concentric conductor and a cross-section of 240 mm² and above:</i>	3,6 kV
Temperature range	
<i>Fixed laying:</i>	- 40 °C / + 70 °C
<i>Flexible application:</i>	- 5 °C / + 50 °C
Max short circuit temperature:	+ 160 °C
Min. bending radius	
<i>Single core:</i>	12 x d
<i>Multi cores:</i>	15 x d
Max. tensile stress	50 N/mm ²

Features:

according to DIN VDE 0276 part 603.1, HD 603 S1 and IEC 60502-1

	re: circular solid conductor
	rm: circular stranded conductor
	sm: sector-shaped stranded conductor
	se: sector-shaped solid conductor

Applications:

Suitable especially for underground laying, for example in subscriber networks, power stations also as control cable for transmission of control impulses and test data

INDUSTRIAL LOW VOLTAGE CABLES

GAALFLEX® VFD NYCWY

Power cable with concentric copper conductor, connection to frequency converters, 0,6/1 kV



ELETTROTEK KABEL® GAALFLEX® VFD NYCWY



Part no.	No. of cores x cross section n x mm ²	Outer-Ø ca. mm ± 10%	Copper weight kg/km	Cable weight approx. kg/km	AWG no. *)
33250G73020M61	2 x 10 re / 10	19	312	650	8
33250G73020M62	2 x 16 re / 16	21	489	850	6
33250G73020M63	2 x 25 rm / 25	24	763	1210	4
33250G73030M61	3 x 10 re / 10	19,5	408	730	8
33250G73030M62	3 x 16 re / 16	22	643	1000	6
33250G73030M63	3 x 25 rm / 16	26	902	1550	4
33250G73030M64	3 x 30 sm / 16	27	1190	1750	2
33250G73030M65	3 x 50 sm / 25	29	1723	2250	1
33250G73030M66	3 x 70 sm / 35	33	2410	2950	2/0
33250G73030M67	3 x 95 sm / 50	38	3296	4100	3/0
33250G73030M68	3 x 120 sm / 70	41	4236	5050	4/0
33250G73030M69	3 x 150 sm / 70	45	5100	6000	250 MCM
33250G73030M70	3 x 185 sm / 95	50	6383	7550	350 MCM
33250G73030M71	3 x 240 sm / 120	57	8242	9950	450 MCM
33251G73030M63	3 x 25 rm / 25	26	1003	1600	4
33251G73030M64	3 x 35 sm / 35	27,5	1402	1850	2
33251G73030M65	3 x 50 sm / 50	29,5	2000	2450	1
33251G73030M66	3 x 70 sm / 70	34	2796	3350	2/0
33251G73030M67	3 x 95 sm / 95	38,5	3791	4550	3/0
33251G73030M68	3 x 120 sm / 120	42	4786	5550	4/0
33251G73030M69	3 x 150 sm / 150	46	5970	6900	250 MCM
33251G73030M70	3 x 185 sm / 185	51	7363	8500	350 MCM
33251G73030M71	3 x 240 sm / 120	57	8242	9950	450 MCM
33250G73040M61	4 x 10 re / 10	20,5	504	890	8
33250G73040M62	4 x 16 re / 16	23,5	796	1250	6
33250G73040M63	4 x 25 rm / 16	28	1142	1800	4
33250G73040M64	4 x 35 sm / 16	29	1526	2050	2
33250G73040M65	4 x 50 sm / 25	33	2203	2700	1
33250G73040M66	4 x 70 sm / 35	37	3082	3750	2/0
33250G73040M67	4 x 95 sm / 50	43,5	4208	5000	3/0
33250G73040M68	4 x 120 sm / 70	47,2	5388	6350	4/0
33250G73040M69	4 x 150 sm / 70	51	6540	7650	250 MCM
33250G73040M70	4 x 185 sm / 95	56	8159	9350	350 MCM
33250G73040M71	4 x 240 sm / 120	62,5	10546	11600	450 MCM

Other dimensions and colours available on request.

INDUSTRIAL LOW VOLTAGE CABLES

(N)AYCWY

Power cable 0,6/1 kV with concentric aluminium conductor, connection to frequency converters



ELETTROTEK KABEL® NAYCWY



Construction:

Conductor:	solid or stranded plain aluminium conductor Cl. 1 or 2, acc. to IEC 60228, DIN VDE 0295 10-16 mm ² - round solid cores 25-240 mm ² - stranded conductor
Insulation:	PVC, type DIV4
Colour cores:	acc. to DIN VDE 0293-308, HD 308 S2
Stranding:	cores stranded concentrically
Screen:	concentric conductor of corrugated copper wires + copper tape
Outer sheath:	black (RAL 9005), PVC, type DMV5

Resistance:







Flame retardant acc. to:
DIN VDE 0482 part 265-2-1
EN 50265-2-1
IEC 60332-1

Technical data:

Nominal voltage:	0,6/1 kV
Test voltage:	4 kV
Temperature range:	- 5 °C / + 70 °C
Min. bending radius:	15 x d
Max. tensile stress:	50 N/mm ²
Current carrying capacity:	as for DIN VDE 0276 part. 603

Features:

-  re: circular solid conductor
-  rm: circular stranded conductor
-  sm: sector-shaped stranded conductor
-  se: sector-shaped solid conductor

Applications:

Power cables for energy supply are installed in open air, in underground, in water, indoors and in cable ducts, power station, for industry and distribution boards as well as in subscriber networks, where mechanical damages are not to be expected.

Part no.	No. of cores x cross section n x mm ²	Outer-Ø ca. mm ± 10%	Copper weight kg/km	Alu weight kg/km	Cable weight approx. kg/km	AWG no. *)
46211G73030M64	3x35 sm/35	27,5	240	305	1300	2
46211G73030M65	3x50 sm/50	29,5	340	435	1400	1
46211G73030M66	3x70 sm/70	34	475	609	1950	2/0
46211G73030M67	3x95 sm/95	38,5	640	827	2500	3/0
46211G73030M68	3x120 sm/120	42	1330	1044	2950	4/0
46211G73030M69	3x150 sm/150	46	1550	1305	3500	250 MCM
46210G73040M62	4x16 re/16	23,5	182	186	950	6
46210G73040M63	4x25 rm/16	28	182	290	1150	4
46210G73040M64	4x35 sm/16	29	182	406	1200	2
46210G73040M65	4x50 sm/25	33	283	580	1600	1
46210G73040M66	4x70 sm/35	37	394	812	2250	2/0
46210G73040M67	4x95 sm/50	43,5	560	1102	2900	3/0
46210G73040M68	4x120 sm/70	47	780	1392	3500	4/0
46210G73040M69	4x150 sm/70	51	780	1740	4200	250 MCM
46210G73040M70	4x185 sm/95	56	1055	2146	4950	350 MCM
46210G73040M71	4x240 sm/120	62,5	1330	2784	5600	450 MCM

Other dimensions and colours available on request.

INDUSTRIAL LOW VOLTAGE CABLES

(N)2XY-J/O FR

Power Cable 0,6/1 kV acc. to IEC 60502-1



ELETTROTEK KABEL® N2XY-J/O FR

Construction:

Conductor:	stranded red copper conductor Cl. 2, acc to IEC 60228, DIN VDE 0295
Insulation:	XLPE, type DIX3
Colour cores:	1 core: Y/G 3 cores: blue-brown-Y/G 4 cores: Y/G, brown, black, grey 5 cores: Y/G-blue-brown-black-grey
Wrapping:	filling compound
Outer sheath:	black(RAL 9005),PVC type DMV6

Resistance:



Flame retardant acc. to:
DIN VDE 0482 part 266-2-4
IEC 60332-1
EN 60332-1-2 EN 60332-3-24

Technical data:

Nominal voltage:	0,6/1 kV
Test voltage:	4 kV
Temperature range:	- 5 °C / + 70 °C
Min. bending radius:	12 x d
Max. permitted operating voltage in 3 phase system:	1,2 kV

Features:

according to IEC 60502-1

on request: water resistant

UV resistance

 re: circular solid conductor

 rm: circular stranded conductor

 sm: sector-shaped stranded conductor

 se: sector-shaped solid conductor

INDUSTRIAL LOW VOLTAGE CABLES

(N)2XY-J/O FR

Power Cable 0,6/1 kV acc. to IEC 60502-1



ELETTROTEK KABEL® N2XY-J/O FR



(N)2XY-J

Part no.	No. of cores x cross section n x mm ²	Outer-Ø ca. mm ± 10%	Copper weight kg/km	Cable weight approx. kg/km	AWG no. *)
46220G72031M15	3G1.5 re	11,3	43,2	177	16
46220G72031M25	3G2.5 re	12	72	223	14
46220G72031M40	3G4 re	13	115,2	291	12
46220G72031M60	3G6 re	14	173	370	10
46220G72031M61	3G10 re	16,9	288	562	8
46220G72031M62	3G16 re	19,2	461	790	6
46220G72031M63	3G25 rm	23,7	720	1234	4
46220G72031M64	3G35 sm	26,6	1008	1620	2
46220G72031M65	3G50 sm	27	1440	1800	1
46220G72031M66	3G70 sm	31,2	2016	2400	2/0
46220G72031M67	3G95 sm	34,5	2736	3300	3/0
46220G72035M63	3G25/16 sm	23	874	1500	4
46220G72035M64	3G35/16 sm	26,2	1162	1700	2
46220G72035M65	3G50/25 sm	30,9	1680	2300	1
46220G72035M66	3G70/35 sm	33,2	2352	2800	2/0
46220G72035M67	3G95/50 sm	39	3216	3800	3/0
46220G72035M68	3G120/70 sm	42,3	4128	4700	4/0
46220G72035M69	3G150/70 sm	46,8	4992	5600	250 MCM
46220G72035M70	3G185/95 sm	51,9	6240	7400	350 MCM
46220G72035M71	3G240/120 sm	59,6	8064	9600	450 MCM
46220G72035M72	3G300/150 sm	66,7	10080	11200	550 MCM
46220G72041M15	4G1.5 re	11,8	58	202	16
46220G72041M25	4G2.5 re	12,8	96	258	14
46220G72041M40	4G4 re	14,1	154	343	12
46220G72041M60	4G6 re	15,2	230,4	442	10
46220G72041M61	4G10 re	18,4	384	678	8
46220G72041M62	4G16 re	21,7	614,4	1013	6
46220G72041M63	4G25 rm	26,2	960	1530	4
46220G72041M64	4G35 rm	27,4	1344	1990	2
46220G72041M65	4G50 sm	29,1	1920	2071	1
46220G72041M66	4G70 sm	31,1	2688	2908	2/0
46220G72041M67	4G95 sm	35,1	3648	3958	3/0
46220G72041M68	4G120 sm	38,8	4608	4959	4/0
46220G72041M69	4G150 sm	42,5	5760	6061	250 MCM
46220G72041M70	4G185 sm	47,5	7104	7632	350 MCM
46220G72051M15	5G1.5 re	13,1	72	270	16
46220G72051M25	5G2.5 re	14,2	120	350	14
46220G72051M40	5G4 re	15,1	192	480	12
46220G72051M60	5G6 re	17,6	288	610	10
46220G72051M61	5G10 re	19,7	480	880	8
46220G72051M62	5G16 re	22,1	768	1250	6
46220G72051M63	5G25 rm	27,2	1200	1950	4
46220G72051M65	5G50 rm	-	2400	3500	1
46220G72051M69	5G150 rm	49	7200	8490	250 MCM
46220G70071M15	7G1.5 re	14	101	300	16
46220G70071M25	7G2.5 re	15,2	168	420	14
46220G70071M40	7G4 re	16,7	269	630	12
46220G70121M15	12G1.5 re	17,5	173	400	16
46220G70121M25	12G2.5 re	18,9	288	560	14
46220G70241M15	24G1.5 re	22,5	346	700	16
46220G70241M25	24G2.5 re	25,4	576	1050	14

Other dimensions and colours available on request.

INDUSTRIAL LOW VOLTAGE CABLES

(N)2XY-J/O FR

Power Cable 0,6/1 kV acc. to IEC 60502-1



ELETTROTEK KABEL® N2XY-J/O FR

(N)2XY-O

Part no.	No. of cores x cross section n x mm ²	Outer-Ø ca. mm ± 10%	Copper weight kg/km	Cable weight approx. kg/km	AWG no. *)
46220G7L010M62	1x16 re	10	154	240	6
46220G7L010M63	1x25 rm	11,8	240	350	4
46220G7L010M64	1x35 rm	13	336	460	2
46220G7L010M65	1x50 rm	14,5	480	600	1
46220G7L010M66	1x70 rm	16,5	672	779	2/0
46220G7L010M67	1x95 rm	18,4	912	1040	3/0
46220G7L010M68	1x120 rm	20,2	1152	1350	4/0
46220G7L010M69	1x150 rm	22,2	1440	1579	250 MCM
46220G7L010M70	1x185 rm	24,8	1776	1981	350 MCM
46220G7L010M71	1x240 rm	27,7	2304	2560	450 MCM
46220G7L010M72	1x300 rm	29,9	2880	3142	550 MCM
46220G7L010M73	1x400 rm	33,5	3840	4100	750 MCM
46220G7L010M74	1x500 rm	38	4800	5200	950 MCM
46220G73020M15	2x1,5 re	10,7	29	159	16
46220G73020M40	2x4 re	12,5	77	249	12
46220G73020M60	2x6 re	13,5	115,2	311	10
46220G73020M61	2x10 re	16	192	465	8
46220G73020M62	2x16 re	18,2	307,2	642	6
46220G73020M63	2x25 re	22,4	480	1000	4
46220G73020M64	2x35 re	25	672	1302	2
46220G73020M65	2x50 re	28	960	1824	1
46220G73020M66	2x70 re	31	1344	2554	2/0

Other dimensions and colours available on request.

INDUSTRIAL LOW VOLTAGE CABLES

U-1000 R2V



ELETTROTEK KABEL® U-1000 R2V

Construction:

Conductor:	solid or stranded red copper conductor Cl. 1 or 2, acc. to IEC 60228
Insulation:	XLPE compound
Colour cores:	2 core: blue-brown 3 cores: brown-black-blue(1,2/2,5 mm ²) 3G cores: Y/G,blue,brown (4 mm ²) 4 cores: blue-brown-black-gray 4G cores: brown-black-gray-Y/G 5 cores: brown-blue-grey-black 5G cores: blue-brown-black-gray-Y/G
Wrapping:	non fibrous and not hygroscopic filler
Outer sheath:	black (RAL 9005),PVC compound

Resistance:



Flame retardant acc. to:
DIN VDE 0482 part 265-2-1
EN 50265-2-1
IEC 60332-1



Oil resistant acc. to:
IEC 60811-2-1
DIN VDE 0473 part 811-2-1

Technical data:

Nominal voltage:	0,6/1 kV
Test voltage:	4 kV
Temperature range:	- 10 °C / + 90 °C
Max short circuit temperature:	+ 250 °C
Min. bending radius:	6 x d

Features:

according to IEC 60502-1

according to NFC 32-321 C32-321/A1

Applications:

For use in industrial sites and the upright columns of buildings. particularly suited in cases of high resistance to solar radiation and atmospheric agents is required good resistance to low temperatures and chemical agents. Can be used without additional mechanical protection in the open air, fixed to walls or in raceways, inside walkways, and in empty in constructions in general. can be laid underground with mechanical protection constructed from slab, tiles, or bricks. It is no recommended to lay this cable in ground flooded for more than two months for year. With appropriate mechanical protection it can be use in areas subject to risk of explosion, but in this case the permitted current load is reduced by 15% It can be used in ambient temperatures down to - 25°.

Part no.	No. of cores x cross section n x mm ²	Outer-Ø ca.mm ± 10%	Copper weight kg/km	Cable weight approx. kg/km	AWG no.)*
46230G7L010M15	1x1,5	6,6	14,4	45	16
46230G7L010M25	1x2,5	7	24	55	14
46230G7L010M40	1x4	7,6	38,4	75	12
46230G7L010M60	1x6	8,2	37,6	100	10
46230G7L010M61	1x10	9,2	96	140	8
46230G7L010M62	1x16	10,5	153,6	205	6
46230G7L010M63	1x25	12,5	240	315	4
46230G7L010M64	1x35	13,5	336	400	2
46230G7L010M65	1x50	15	480	530	1
46230G7L010M66	1x70	17	672	725	2/0
46230G7L010M67	1x95	19	912	985	3/0
46230G7L010M68	1x120	21	1152	1260	4/0
46230G7L010M69	1x150	23	1440	1520	250 MCM
46230G7L010M70	1x185	25,5	1776	1940	350 MCM
46230G7L010M71	1x240	28,5	2304	2310	450 MCM
46230G7L010M72	1x300	31	2880	3200	550 MCM

INDUSTRIAL LOW VOLTAGE CABLES

U-1000 R2V



ELETTROTEK KABEL® U-1000 R2V

Part no.	No. of cores x cross section n x mm ²	Outer-Ø ca. mm ± 10%	Copper weight kg/km	Cable weight approx. kg/km	AWG no. *)
46230G73020M15	2x1.5	10,5	28,8	115	16
46230G73020M25	2x2.5	11,5	48	145	14
46230G73020M40	2x4	13	76,8	195	12
46230G73020M60	2x6	14	115,2	265	10
46230G73020M61	2x10	16	192	390	8
46230G73020M62	2x16	18,5	307,2	560	6
46230G73020M63	2x25	22	480	850	4
46230G73020M64	2x35	24,5	672	1080	2
46230G73030M15	3x1,5	11	43,2	130	16
46230G73030M25	3x2,5	12,5	72	170	14
46230G73030M40	3x4	13,5	115,2	230	12
46230G73030M60	3x6	15	172,8	325	10
46230G73030M61	3x10	17	288	485	8
46230G73030M62	3x16	19,5	460,8	705	6
46230G73030M63	3x25	23,5	720	1080	4
46230G73030M64	3x35	26	1008	1390	2
46230G73030M65	3x50	29	1440	1840	1
46230G73030M66	3x70	34	2016	2540	2/0
46230G73030M67	3x95	38,5	2736	3430	3/0
46230G73030M68	3x120	42,5	3456	4440	4/0
46230G73030M69	3x150	47,5	4320	5380	250 MCM
46230G73030M70	3x185	53	5328	6920	350 MCM
46230G73030M71	3x240	59,5	6912	8420	450 MCM
46230G73030M72	3x300	66,0	8640	11300	550 MCM
46230G72041M15	4G1,5	12	59,4	150	16
46230G72041M25	4G2,5	13	96	205	14
46230G72041M40	4G4	14,5	153,6	280	12
46230G72041M60	4G6	16	230,4	390	10
46230G72041M61	4G10	18,5	384	590	8
46230G72041M62	4G16	21	614,4	870	6
46230G72041M63	4G25	25,5	960	1365	4
46230G72041M64	4G35	28,5	1344	1760	2
46230G73035M65	3x50+1x35	31,1	1776	2160	1
46230G73035M66	3x70+1x50	36,2	2496	3010	2/0
46230G73035M67	3x95+1x50	40,6	3216	3960	3/0
46230G73035M68	3x120+1x70	45,4	4128	5160	4/0
46230G73035M69	3x150+1x70	49,5	4992	6150	250 MCM
46230G73035M70	3x185+1x70	54,4	6000	7780	350 MCM
46230G73035M71	3x240+1x95	61,5	7824	9550	450 MCM
46230G73050M15	5x1,5	13	72	180	16
46230G73050M25	5x2,5	14,5	120	240	14
46230G73050M40	5x4	16	192	335	12
46230G73050M60	5x6	17,5	288	475	10
46230G73050M61	5x10	20	480	720	8
46230G73050M62	5x16	23	768	1060	6
46230G73050M63	5x25	28	1200	1645	4
46230G70071M15	7x1,5	13,5	100,8	220	16
46230G70071M25	7x2,5	15	168	310	14
46230G70101M15	10x1,5	16,5	144	310	16
46230G70101M25	10x2,5	19	240	440	14
46230G70121M15	12x1,5	17	172,8	370	16
46230G70121M25	12x2,5	19,5	240	525	14
46230G70141M15	14x1,5	18	201,6	430	16
46230G70141M25	14x2,5	20,5	336	610	14
46230G70191M15	19x1,5	19,5	273,6	560	16
46230G70191M25	19x2,5	22,5	456	745	14
46230G70241M15	24x1,5	22,5	345,6	710	16
46230G70241M25	24x2,5	25,5	576	1000	14

Other dimensions and colours available on request.

U-1000 RV FV



ELETTROTEK KABEL® U-1000 RV FV

Construction:

Conductor:	solid or stranded red copper conductor Cl. 1 or 2, acc. to IEC 60228
Insulation:	XLPE compound
Colour cores:	acc. to DIN VDE 0293-308, HD 308 S2 from 6 cores black cores with consecutive numbers acc. to EN 50334; green-yellow earth-wire from 3 cores
Wrapping:	non fibrous and not hygroscopic filler
Inner sheath:	PVC compound
Armour:	steel tape
Outer sheath:	black (RAL 9005),PVC compound

Resistance:



Flame retardant acc. to:
DIN VDE 0482 part 265-2-1
EN 50265-2-1
IEC 60332-1

Technical data:

Nominal voltage:	0,6/1 kV
Test voltage:	4 kV
Temperature range:	- 15 °C / + 90 °C
Min. bending radius	
<i>Fixed laying:</i>	8 x d
<i>Flexible application:</i>	16 x d

Features:

according to IEC 60502-1

according to NFC 32-321 C32-321/A1

Applications:

For use in industrial sites and the upright columns of buildings. particularly suited in cases of high resistance to solar radiation and atmospheric agents is required good resistance to low temperatures and chemical agents. Can be used without additional mechanical protection in the open air, fixed to walls or in raceways, inside walkways, and in empty in constructions in general. can be laid underground with mechanical protection constructed from slab, tiles, or bricks. It is no recommended to lay this cable in ground flooded for more than two months for year. With appropriate mechanical protection it can be use in areas subject to risk of explosion, but in this case the permitted current load is reduced by 15% It can be used in ambient temperatures down to - 25°.

INDUSTRIAL LOW VOLTAGE CABLES

U-1000 RV FV



ELETTROTEK KABEL® U-1000 RV FV

Part no.	No. of cores x cross section n x mm ²	Outer-Ø ca. mm ± 10%	Copper weight kg/km	Cable weight approx. kg/km	AWG no. *)
46240G72031M64	3G35	26	1008	1700	2
46240G72031M65	3G50	29	1440	2195	1
46240G72031M66	3G70	34	2016	3015	2/0
46240G72031M67	3G95	38,5	2736	4300	3/0
46240G72031M68	3G120	42,5	3456	5250	4/0
46240G72031M69	3G150	47,5	4320	6480	250 MCM
46240G72031M70	3G185	53	5328	8020	350 MCM
46240G72031M71	3G240	59,5	6912	10170	450 MCM
46240G72031M72	3G300	66	8640	12170	550 MCM
46240G72041M15	4G1,5	12	59,4	278	16
46240G72041M25	4G2,5	13	96	344	14
46240G72041M40	4G4	14,5	153,6	430	12
46240G72041M60	4G6	16	230,4	579	10
46240G72041M61	4G10	18,5	384	799	8
46240G72041M62	4G16	21	614,4	1096	6
46240G72041M63	4G25	25,5	960	1610	4
46240G72041M64	4G35	28,5	1344	2090	2
46240G72041M65	4x50	32,5	1920	2710	1
46240G72041M66	4x70	39,5	2688	4180	2/0
46240G72041M67	4x95	44	3648	5320	3/0
46240G72041M68	4x120	49,2	4608	6750	4/0
46240G72041M69	4x150	54	5760	8110	300 MCM
46240G72041M70	4x185	59,5	7104	9990	350 MCM
46240G72041M71	4x240	67	9216	12730	500 MCM
46240G72041M72	4x300	73,5	11520	15500	600 MCM
46240G72035M64	3x35+1x25	28,5	1248	2000	2
46240G72035M65	3x50+1x35	31,1	1776	2575	1
46240G72035M66	3x70+1x50	36,2	2496	3560	2/0
46240G72035M67	3x95+1x50	40,6	3216	4810	3/0
46240G72035M68	3x120+1x70	45,4	4128	6100	4/0
46240G72035M69	3x150+1x70	49,5	4992	7225	250 MCM
46240G72035M70	3x185+1x70	54,4	6000	8650	350 MCM
46240G72035M71	3x240+1x95	61,5	7824	11020	450 MCM
46240G72051M15	5G1,5	13	72	310	16
46240G72051M25	5G2,5	14,5	120	390	14
46240G72051M40	5G4	16	192	495	12
46240G72051M60	5G6	17,5	288	645	10
46240G72051M61	5G10	20	480	910	8
46240G72051M62	5G16	23	768	1290	6
46240G72051M63	5G25	28	1200	1900	4
46240G70071M15	7G1,5	13,5	100,8	245	16
46240G70071M25	7G2,5	15	168	335	14
46240G70121M15	12G1,5	17	172,8	370	16
46240G70121M25	12G2,5	19,5	240	520	14
46240G70191M15	19G1,5	19,5	273,6	530	16
46240G70191M25	19G2,5	22,5	456	750	14
46240G70241M15	24G1,5	22,5	345,6	650	16
46240G70241M25	24G2,5	25,5	576	930	14
46240G73020M15	2x1,5	11,7	28,8	210	16
46240G73020M25	2x2,5	12,5	48	253	14
46240G73020M40	2x4	13,7	76,8	311	12
46240G73020M60	2x6	15	115,2	409	10
46240G73020M61	2x10	16,7	192	548	8
46240G73020M62	2x16	18,7	307,2	720	6
46240G73020M63	2x25	22,2	480	1110	4
46240G73020M64	2x35	24,7	672	1400	2
46240G73030M15	3x1,5	12,2	43,2	240	16
46240G73030M25	3x2,5	13	72	295	14
46240G72031M40	3G4	14,2	115,2	365	12
46240G72031M60	3G6	15,7	172,8	491	10
46240G72031M61	3G10	17,5	288	665	8
46240G72031M62	3G16	19,7	460,8	898	6
46240G72031M63	3G25	23,5	720	1320	4

Other dimensions and colours available on request.

ELETTROTEK KABEL® RV-K

Construction:

Conductor:	flexible red copper conductor Cl.5, acc. to IEC 60228
Insulation:	XLPE, type DIX3
Colour cores:	acc. to DIN VDE 0293-308, HD 308 S2 from 6 cores black cores with consecutive numbers acc. to EN 50334; green-yellow earth-wire from 3 cores
Outer sheath:	black (RAL 9005), PVC compound

Technical data:

Nominal voltage:	0,6/1 kV
Test voltage:	3,5 kV
Temperature range	
<i>Fixed laying:</i>	- 50 °C / + 90 °C
<i>Flexible application:</i>	- 35 °C / + 90 °C
Max short circuit temperature:	+ 250 °C
Min. bending radius:	5 x d

Resistance:



Flame retardant acc. to:
DIN VDE 0482 part 265-2-1
EN 50265-2-1
IEC 60332-1

Features:

according to IEC 60502-1

according to HD603-1



re: circular solid conductor



rm: circular stranded conductor



sm: sector-shaped stranded conductor



se: sector-shaped solid conductor

Applications:

This cable for energy distribution is suitable for all types of low voltage industrial-type connections. Its high flexibility makes the installation process substantially easier and as a result is particularly suitable for use in difficult layouts. It can be buried or installed in a tube as well as outdoors without requiring additional protection. Lastly, RV-K cable can withstand damp conditions.

INDUSTRIAL LOW VOLTAGE CABLES

RV-K



ELETTROTEK KABEL® RV-K

Part no.	No. of cores x cross section n x mm ²	Outer-Ø ca. mm ± 10%	Copper weight kg/km	Cable weight approx. kg/km	AWG no.*)
46250G7L010M40	1x4 re	6,8	38	70	12
46250G7L010M60	1x6 re	7,2	58	90	10
46250G7L010M61	1x10 re	8,3	96	131	8
46250G7L010M62	1x16 re	9,5	154	193	6
46250G7L010M63	1x25 rm	10,9	240	281	4
46250G7L010M64	1x35 rm	12	336	375	2
46250G7L010M65	1x50 rm	13,7	480	515	1
46250G7L010M66	1x70 rm	15,7	672	705	2/0
46250G7L010M67	1x95 rm	17,5	912	925	3/0
46250G7L010M68	1x120 rm	19,3	1152	1150	4/0
46250G7L010M69	1x150 rm	21,7	1440	1450	250 MCM
46250G7L010M70	1x185 rm	24	1776	1770	350 MCM
46250G7L010M71	1x240 rm	26,7	2304	2300	450 MCM
46250G7L010M72	1x300 rm	30,1	2880	2820	550 MCM
46250G73020M15	2x1,5 re	8,2	29	85	16
46250G73020M25	2x2,5 re	9,1	48	110	14
46250G73020M40	2x4 re	10,4	77	155	12
46250G73020M60	2x6 re	11,4	15	205	10
46250G73020M61	2x10 re	13,5	192	310	8
46250G73020M62	2x16 re	15,2	307	456	6
46250G73020M63	2x25 rm	18	480	670	4
46250G73030M15	3x1,5 re	8,8	43	100	16
46250G72031M15	3G1,5 re	8,8	43	100	16
46250G73030M25	3x2,5 re	9,8	72	140	14
46250G72031M25	3G2,5 re	9,8	72	140	14
46250G73030M40	3x4 re	11,1	115	195	12
46250G73030M60	3x6 re	12,2	173	262	10
46250G73030M61	3x10 re	14,3	288	395	8
46250G73030M62	3x16 re	16,5	461	590	6
46250G73030M63	3x25 rm	19,6	720	870	4
46250G73040M15	4x1,5 re	9,5	57,6	120	16
46250G73040M25	4x2,5 re	10,8	96,0	175	14
46250G72041M25	4G2,5 rm	10,8	96,0	175	14
46250G73040M40	4x4 re	12,2	153,6	245	12
46250G73040M60	4x6 re	13,4	230,4	325	10
46250G72041M60	4G6 re	13,4	230,4	325	10
46250G73040M61	4x10 re	15,7	384	495	8
46250G72041M61	4G10 re	15,7	384	495	8
46250G73040M62	4x16 re	18,6	614,4	760	6
46250G72041M62	4G16 re	18,6	614,4	760	6
46250G73040M63	4x25 rm	22	960	1130	4
46250G72041M63	4G25 rm	22	960	1130	4
46250G73040M64	4x35 sm	26	1344	1630	2
46250G73040M65	4x50 sm	31	1920	2320	1
46250G73040M66	4x70 sm	36,4	2688	3230	2/0
46250G73040M67	4x95 sm	41	3648	4200	3/0
46250G72051M15	5G1,5	10,5	72	150	16
46250G72051M25	5G2,5	12	120	205	14
46250G72051M40	5G4	13,5	192	300	12
46250G72051M60	5G6	14,9	288	400	10
46250G72051M61	5G10	17,4	480	61	8
46250G72051M62	5G16	20,5	768	930	6
46250G72051M63	5G25	24,3	1200	1380	4
46250G72051M64	5G35	28,8	1680	1995	2

Other dimensions and colours available on request.

RE4(O)R (XLPE/PVC)



ELETTROTEK KABEL® RE4OR

Construction:

Conductor:	stranded red copper conductor Cl. 2, acc to IEC 60228
Insulation:	XLPE compound
Colour cores:	acc. to DIN VDE 0293-308, HD 308 S2 from 6 cores black cores with consecutive numbers acc. to EN 50334; green-yellow earth-wire from 3 cores
Outer sheath:	black (RAL 9005),PVC compound

Resistance:



Flame retardant acc. to:
DIN VDE 0482 part 265-2-1
EN 50265-2-1
IEC 60332-1-2

Technical data:

Nominal voltage:	0,6/1 kV
Test voltage:	4 kV
Temperature range:	- 15 °C / + 90 °C
Max short circuit temperature:	+ 250 °C
Min. bending radius:	6 x d

Features:

according to IEC 60502-1

INDUSTRIAL LOW VOLTAGE CABLES

RE4(O)R (XLPE/PVC)



ELETTROTEK KABEL® RE4OR



Part no.	No. of cores x cross section n x mm ²	Outer-Ø ca. mm ± 10%	Copper weight kg/km	Cable weight approx. kg/km	AWG no. *)
46260G7L010M15	1x1,5	5,5	4,8	45	16
46260G7L010M25	1x2,5	6	24	60	14
46260G7L010M40	1x4	6,5	38,4	75	12
46260G7L010M60	1x6	7	57,6	95	10
46260G7L010M61	1x10	8	96	140	8
46260G7L010M62	1x16	9	153	195	6
46260G7L010M63	1x25	11	240	285	4
46260G7L010M64	1x35	12	336	380	2
46260G7L010M65	1x50	13,5	480	520	1
46260G7L010M66	1x70	15,5	672	720	2/0
46260G7L010M67	1x95	17,5	912	930	3/0
46260G7L010M68	1x120	19,5	1152	1170	4/0
46260G7L010M69	1x150	21,5	1440	1450	250 MCM
46260G7L010M70	1x185	23	1776	1740	350 MCM
46260G7L010M71	1x240	26,5	2304	2310	450 MCM
46260G7L010M72	1x300	30	2880	2890	550 MCM
46260G7L010M73	1x400	35	3840	3920	750 MCM
46260G7L010M74	1x500	39	4800	5015	1000 MCM
46260G7L010M75	1x630	43,5	6048	6585	1250 MCM
46260G73020M15	2x1,5	8,5	28,8	100	16
46260G73020M25	2x2,5	9,5	48	130	14
46260G73020M40	2x4	10,5	76,8	170	12
46260G73020M60	2x6	11,5	115,2	220	10
46260G73020M61	2x10	13,5	192	330	8
46260G73020M62	2x16	15,5	307,2	470	6
46260G73020M63	2x25	19	480	705	4
46260G73020M64	2x35	21	672	945	2
46260G72031M15	3G1,5	9	43,2	115	16
46260G72031M25	3G2,5	10	72	155	14
46260G72031M40	3G4	11	115,2	205	12
46260G72031M60	3G6	12	172,8	275	10
46260G72031M61	3G10	14	288	420	8
46260G72031M62	3G16	16,5	460	605	6
46260G72031M63	3G25	20	720	910	4
46260G72031M64	3G35	22,5	1008	1235	2
46260G72041M15	4G1,5	10	57,6	140	16
46260G72041M25	4G2,5	11	96	185	14
46260G72041M40	4G4	12	153,6	255	12
46260G72041M60	4G6	13,5	230,4	340	10
46260G72041M61	4G10	16	384	530	8
46260G72041M62	4G16	18,5	614,4	770	6
46260G72041M63	4G25	22,5	960	1165	4
46260G72041M64	4G35	25	1344	1570	2
46260G73050M15	5x1,5	12,7	72	225	16
46260G71070M15	7x1,5	13,1	100,8	260	16
46260G71100M15	10x1,5	13,8	144	-	16
46260G71120M15	12x1,5	15,2	172,8	385	16
46260G71190M15	19x1,5	17,3	273,6	-	16
46260G71240M15	24x1,5	20,2	345,6	880	16
46260G71070M25	7x2,5	13,5	168	365	14
46260G71100M25	10x2,5	15,9	240	-	14
46260G71120M25	12x2,5	17,3	288	542,5	14
46260G71190M25	19x2,5	21,3	456	-	14
46260G71240M25	24x2,5	24,6	576	1025	14

Other dimensions and colours available on request.

FE4(O)CR

inverter, connection to frequency converters



ELETTROTEK KABEL® FE4OCR



Construction:

- Conductor:** flexible red copper conductor Cl.5, acc. to IEC 60228
- Insulation:** XLPE compound
- Colour cores:** acc. to DIN VDE 0293-308, HD 308 (brown - gray - black)
- Stranding:** cores laying to concentric crowns to ensure roundness to the cable
- Inner sheath:** PVC compound
- Screen:** red copper braid of the same section as the phase conductor (for sections up to 16 mm²) or equal to half phase conductor, with a minimum of 16 mm² (for section greater than 25 mm²)
- Outer sheath:** grey (RAL 7001), PVC, type Rz

Resistance:



Flame retardant acc. to:
DIN VDE 0482 part 265-2-1
EN 50265-2-1
IEC 60332-1 CEI 20-22 III

Technical data:

- Nominal voltage:** 0,6/1 kV
- Test voltage:** 4 kV
- Temperature range:** - 20 °C / + 90 °C
- Max short circuit temperature:** + 250 °C
- Min. bending radius:** 8 x d

Features:

- according to IEC 60502-1 and CEI 20-13
- according to CEI-UNEL 35375

Part no.	No. of cores x cross section n x mm ²	Outer-Ø ca. mm ± 10%	Copper weight kg/km	Cable weight approx. kg/km	AWG no. *)
33200G83030M25	3x2,5+SH	14,6	96	340	14
33200G83030M40	3x4+SH	15,8	134	400	12
33200G83030M60	3x6+SH	18,7	231	490	10
33200G83030M61	3x10+SH	21,7	336	720	8
33200G83030M62	3x16+SH	25,3	615	1040	6
33200G83030M63	3x25+SH	28,8	873	1410	4
33200G83030M64	3x35+SH	32,2	1162	1870	2
33200G83030M65	3x50+SH	36	1680	2400	1
33200G83030M66	3x70+SH	40,7	2352	3360	2/0
33200G83030M67	3x95+SH	47,6	3192	4350	3/0
33200G83030M68	3x120+SH	52,2	4032	5540	4/0
33200G83030M69	3x150+SH	56,4	5040	6880	250 MCM
33200G83030M70	3x185+SH	64,8	6216	8350	350 MCM
33200G83030M71	3x240+SH	74,5	8604	11540	450 MCM
33200G83030M72	3x300+SH	85,5	10080	13480	550 MCM

Other dimensions and colours available on request.

INDUSTRIAL LOW VOLTAGE CABLES

RE4(O)FR (XLPE/PVC/SWA/PVC)

Construction acc. to IEC 60502-1



ELETTROTEK KABEL® RE4OFR



Construction:

Conductor:	stranded red copper conductor Cl. 2, acc to IEC 60228
Insulation:	XLPE compound
Colour cores:	acc. to DIN VDE 0293-308, HD 308 S2 from 6 cores black cores with consecutive numbers acc. to EN 50334; green-yellow earth-wire from 3 cores
Inner sheath:	PVC compound
Armour:	steel wires
Outer sheath:	black (RAL 9005),PVC compound

Resistance:



Flame retardant and self extinguishing acc. to:
DIN VDE 0482 part 266-2-4
EN 50266-2-4
IEC 60332-1-2

Technical data:

Nominal voltage:	0,6/1 kV
Test voltage:	4 kV
Temperature range:	- 0 °C / + 90 °C
Max short circuit temperature:	+ 250 °C
Min. bending radius:	8 x d

Features:

according to IEC 60502-1
on request 300/500 V

INDUSTRIAL LOW VOLTAGE CABLES

RE4(O)FR (XLPE/PVC/SWA/PVC)

Construction acc. to IEC 60502-1



ELETTROTEK KABEL® RE4OFR



Part no.	No. of cores x cross section n x mm ²	Outer-Ø ca. mm ± 10%	Copper weight kg/km	Cable weight approx. kg/km	AWG no. *)
46270G73020M15	2 x 1,5	12,3	28,8	300	16
46270G73020M25	2 x 2,5	13,6	48	360	14
46270G73020M40	2 x 4	14,7	76,8	420	12
46270G73020M60	2 x 6	15,9	115,2	500	10
46270G73020M61	2 x 10	18	192	650	8
46270G73020M62	2 x 16	20	307,2	910	6
46270G73020M63	2 x 25	24,1	480	1060	4
46270G73020M64	2 x 35	27,9	672	1480	2
46270G73020M65	2 x 50	25,8	960	1800	1
46270G73020M66	2 x 70	29	1344	2300	2/0
46270G73020M67	2 x 95	33,1	1824	3170	3/0
46270G73020M68	2 x 120	36,1	2304	3800	4/0
46270G73020M69	2 x 150	39,3	2880	4500	300 MCM
46270G73020M70	2 x 185	44,7	3552	5800	350 MCM
46270G73020M71	2 x 240	59	4608	7280	500 MCM
46270G73020M72	2 x 300	53,5	5760	8750	600 MCM
46270G73020M73	2 x 400	59	7680	10700	750 MCM
46270G72031M15	3 G 1,5	12,8	43,2	341	16
46270G72031M25	3 G 2,5	14,1	72	405	14
46270G72031M40	3 G 4	15,3	115,2	495	12
46270G72031M60	3 G 6	16,6	172,8	600	10
46270G72031M61	3 G 10	19,5	288	900	8
46270G72031M62	3 G 16	21,2	460,8	1080	6
46270G72031M63	3 G 25	26,7	720	1750	4
46270G72031M64	3 G 35	29,6	1008	2100	2
46270G72031M65	3 G 50	28,5	1440	2350	1
46270G72031M66	3 G 70	32,2	2016	3150	2/0
46270G72031M67	3 G 95	37	2736	4300	3/0
46270G72031M68	3 G 120	40,4	3456	5250	4/0
46270G72031M69	3G 150	45,5	4320	6720	300 MCM
46270G72031M70	3 G 185	49,8	5328	8040	350 MCM
46270G72031M71	3 G 240	55,1	6912	10150	500 MCM
46270G72031M72	3 G 300	60,2	8640	12320	600 MCM
46270G72031M73	3 G 400	66,6	11520	15090	750 MCM
46270G72041M15	4 G 1,5	13,5	57,6	390	16
46270G72041M25	4 G 2,5	15	96	465	14
46270G72041M40	4 G 4	16,4	153,6	579	12
46270G72041M60	4 G 6	18,7	230,4	820	10
46270G72041M61	4 G 10	21,1	384	1090	8
46270G72041M62	4 G 16	22,9	614,4	1400	6
46270G72041M63	4 G 25	28,9	960	2100	4
46270G72041M64	4 G 35	32,1	1344	2580	2
46270G72041M65	4 G 50	32	1920	3000	1
46270G72041M66	4 G 70	37,7	2688	4300	2/0
46270G72041M67	4 G 95	41,7	3648	5510	3/0
46270G72041M68	4 G 120	47,1	4608	7150	4/0
46270G72041M69	4 G 150	51,4	5760	8500	300 MCM
46270G72041M70	4 G 185	56,6	7104	10300	350 MCM
46270G72041M71	4 G 240	63	9216	13000	500 MCM
46270G72041M72	4 G 300	68,8	11520	15750	600 MCM
46270G72041M73	4 G 400	78,1	15360	20450	750 MCM

INDUSTRIAL LOW VOLTAGE CABLES

RE4(O)FR (XLPE/PVC/SWA/PVC)

Construction acc. to IEC 60502-1



ELETTROTEK KABEL® RE4OFR



Part no.	No. of cores x cross section n x mm ²	Outer-Ø ca. mm ± 10%	Copper weight kg/km	Cable weight approx. kg/km	AWG no. *)
46270G73050M15	5 x 1,5	14,2	72	433	16
46270G73050M25	5 x 2,5	16	120	530	14
46270G73050M40	5 x 4	18,4	192	775	12
46270G73050M60	5 x 6	19,7	288	929	10
46270G73050M61	5 x 10	23,2	480	1300	8
46270G73050M62	5 x 16	26,6	768	1880	6
46270G73050M63	5 x 25	31,7	1200	2670	4
46270G73050M64	5 x 35	33	1680	2800	2
46270G71060M15	6 x 1,5	15,2	86,4	497	16
46270G71060M25	6 x 2,5	17,1	144	609	14
46270G71060M40	6 x 4	19,7	230,4	886	12
46270G71060M60	6 x 6	21,3	345,6	1070	10
46270G71060M61	6 x 10	25,6	576	1650	8
46270G71060M62	6 x 16	28,8	921,6	2190	6
46270G71060M63	6 x 25	34,1	1440	3090	4
46270G71070M15	7 x 1,5	15,2	100,8	506	16
46270G71070M25	7 x 2,5	17,1	168	618	14
46270G71070M40	7 x 4	19,7	268,8	907	12
46270G71070M60	7 x 6	21,3	403,2	1110	10
46270G71070M61	7 x 10	25,6	672	1720	8
46270G71070M62	7 x 16	28,8	1075,2	2300	6
46270G71070M63	7 x 25	38,6	1680	3900	4
46270G71080M15	8 x 1,5	17,6	115,2	663	16
46270G71080M25	8 x 2,5	18,8	192	793	14
46270G71080M40	8 x 4	21,2	396,8	1030	12
46270G71080M60	8 x 6	24,1	460,8	1440	10
46270G71080M61	8 x 10	27,7	768	1960	8
46270G71100M15	10 x 1,5	19,8	144	812	16
46270G71100M25	10 x 2,5	21,4	240	989	14
46270G71100M40	10 x 4	25,1	384	1410	12
46270G71100M60	10 x 6	27,3	576	1680	10
46270G71100M61	10 x 10	31,5	960	2320	8
46270G71120M15	12 x 1,5	19,4	172,8	854	16
46270G71120M25	12 x 2,5	22,4	288	1080	14
46270G71120M40	12 x 4	27,7	460,8	1550	12
46270G71120M60	12 x 6	28	691,2	1920	10
46270G71120M61	12 x 10	32,3	1152	2660	8
46270G71160M15	16 x 1,5	21,9	230,4	1020	16
46270G71160M25	16 x 2,5	25	384	1430	14
46270G71160M40	16 x 4	29,1	614,4	1950	12
46270G71160M60	16 x 6	30,4	921,6	2300	10
46270G71190M15	19 x 1,5	23,2	273,6	1120	16
46270G71190M25	19 x 2,5	26,1	456	1570	14
46270G71190M40	19 x 4	29,3	729,6	2050	12
46270G71220M15	22 x 1,5	27,3	316,8	1560	16
46270G71220M25	22 x 2,5	29,7	528	1930	14
46270G71220M40	22 x 4	33,5	844,8	2530	12
46270G71270M15	27 x 1,5	27,9	388,8	1630	16
46270G71270M25	27 x 2,5	30,2	648	2050	14
46270G71270M40	27 x 4	34,2	1036,8	2740	12
46270G71300M15	30 x 1,5	28,5	432	1730	16
46270G71300M25	30 x 2,5	31,3	720	2200	14
46270G71370M15	37 x 1,5	30,6	532,8	1970	16
46270G71370M25	37 x 2,5	33,8	888	2540	14
46270G71370M40	37 x 4	39,6	1420,8	-	12
46270G71400M15	40 x 1,5	31,5	576	2080	16
46270G71400M25	40 x 2,5	35,9	960	2970	14
46270G71480M15	48 x 1,5	33,9	691,2	2390	16
46270G71480M25	48 x 2,5	38,8	1152	3430	14
46270G71480M40	48 x 4	44,6	1843,2	-	12

Other dimensions and colours available on request.

RE4(O)FR (XLPE/PVC/SWA/PVC)

0,6/1 kV according to BS 5467



ELETTROTEK KABEL® RE4OFR



Construction:

Conductor:	stranded red copper conductor Cl. 2, acc to IEC 60228
Insulation:	XLPE compound
Colour cores:	acc. to DIN VDE 0293-308, HD 308 S2 from 6 cores black cores with consecutive numbers acc. to EN 50334; green-yellow earth-wire from 3 cores
Inner sheath:	PVC compound
Armour:	steel wires
Outer sheath:	black (RAL 9005),PVC compound

Technical data:

Nominal voltage:	0,6/1 kV
Test voltage:	4 kV
Temperature range:	- 0 °C / + 90 °C
Max short circuit temperature:	+ 250 °C
Min. bending radius:	8 x d

Resistance:



Flame retardant and self extinguishing acc. to:
DIN VDE 0482 part 266-2-4
EN 50266-2-4
IEC 60332-1-2

Features:

according to BS 5467
according to IEC 60502-1
on request 300/500 V

INDUSTRIAL LOW VOLTAGE CABLES

RE4(O)FR (XLPE/PVC/SWA/PVC)

0,6/1 kV according to BS 5467



ELETTROTEK KABEL® RE4OFR



Part no.	No. of cores x cross section n x mm ²	Outer-Ø ca. mm ± 10%	Copper weight kg/km	Cable weight approx. kg/km	AWG no. *)
46280G73020M15	2 x 1,5	12,3	28,8	300	16
46280G73020M25	2 x 2,5	13,6	48	360	14
46280G73020M40	2 x 4	14,7	76,8	420	12
46280G73020M60	2 x 6	15,9	115,2	500	10
46280G73020M61	2 x 10	18	192	650	8
46280G73020M62	2 x 16	20	307,2	910	6
46280G73020M63	2 x 25	24,1	480	1060	4
46280G73020M64	2 x 35	27,9	672	1480	2
46280G73020M65	2 x 50	25,8	960	1800	1
46280G73020M66	2 x 70	29	1344	2300	2/0
46280G73020M67	2 x 95	33,1	1824	3170	3/0
46280G73020M68	2 x 120	36,1	2304	3800	4/0
46280G73020M69	2 x 150	39,3	2880	4500	300 MCM
46280G73020M70	2 x 185	44,7	3552	5800	350 MCM
46280G73020M71	2 x 240	59	4608	7280	500 MCM
46280G73020M72	2 x 300	53,5	5760	8750	600 MCM
46280G73020M73	2 x 400	59	7680	10700	750 MCM
46280G72031M15	3 G 1,5	12,8	43,2	341	16
46280G72031M25	3 G 2,5	14,1	72	405	14
46280G72031M40	3 G 4	15,3	115,2	495	12
46280G72031M60	3 G 6	16,6	172,8	600	10
46280G72031M61	3 G 10	19,5	288	900	8
46280G72031M62	3 G 16	21,2	460,8	1080	6
46280G72031M63	3 G 25	26,7	720	1750	4
46280G72031M64	3 G 35	29,6	1008	2100	2
46280G72031M65	3 G 50	28,5	1440	2350	1
46280G72031M66	3 G 70	32,2	2016	3150	2/0
46280G72031M67	3 G 95	37	2736	4300	3/0
46280G72031M68	3 G 120	40,4	3456	5250	4/0
46280G72031M69	3G 150	45,5	4320	6720	300 MCM
46280G72031M70	3 G 185	49,8	5328	8040	350 MCM
46280G72031M71	3 G 240	55,1	6912	10150	500 MCM
46280G72031M72	3 G 300	60,2	8640	12320	600 MCM
46280G72031M73	3 G 400	66,6	11520	15090	750 MCM
46280G72041M15	4 G 1,5	13,5	57,6	390	16
46280G72041M25	4 G 2,5	15	96	465	14
46280G72041M40	4 G 4	16,4	153,6	579	12
46280G72041M60	4 G 6	18,7	230,4	820	10
46280G72041M61	4 G 10	21,1	384	1090	8
46280G72041M62	4 G 16	22,9	614,4	1400	6
46280G72041M63	4 G 25	28,9	960	2100	4
46280G72041M64	4 G 35	32,1	1344	2580	2
46280G72041M65	4 G 50	32	1920	3000	1
46280G72041M66	4 G 70	37,7	2688	4300	2/0
46280G72041M67	4 G 95	41,7	3648	5510	3/0
46280G72041M68	4 G 120	47,1	4608	7150	4/0
46280G72041M69	4 G 150	51,4	5760	8500	300 MCM
46280G72041M70	4 G 185	56,6	7104	10300	350 MCM
46280G72041M71	4 G 240	63	9216	13000	500 MCM
46280G72041M72	4 G 300	68,8	11520	15750	600 MCM
46280G72041M73	4 G 400	78,1	15360	20450	750 MCM

INDUSTRIAL LOW VOLTAGE CABLES

RE4(O)FR (XLPE/PVC/SWA/PVC)

0,6/1 kV according to BS 5467



ELETTROTEK KABEL® RE4OFR



Part no.	No. of cores x cross section n x mm ²	Outer-Ø ca. mm ± 10%	Copper weight kg/km	Cable weight approx. kg/km	AWG no. *)
46280G73050M15	5 x 1,5	14,2	72	433	16
46280G73050M25	5 x 2,5	16	120	530	14
46280G73050M40	5 x 4	18,4	192	775	12
46280G73050M60	5 x 6	19,7	288	929	10
46280G73050M61	5 x 10	23,2	480	1300	8
46280G73050M62	5 x 16	26,6	768	1880	6
46280G73050M63	5 x 25	31,7	1200	2670	4
46280G73050M64	5 x 35	33	1680	2800	2
46280G71060M15	6 x 1,5	15,2	86,4	497	16
46280G71060M25	6 x 2,5	17,1	144	609	14
46280G71060M40	6 x 4	19,7	230,4	886	12
46280G71060M60	6 x 6	21,3	345,6	1070	10
46280G71060M61	6 x 10	25,6	576	1650	8
46280G71060M62	6 x 16	28,8	921,6	2190	6
46280G71060M63	6 x 25	34,1	1440	3090	4
46280G71070M15	7 x 1,5	15,2	100,8	506	16
46280G71070M25	7 x 2,5	17,1	168	618	14
46280G71070M40	7 x 4	19,7	268,8	907	12
46280G71070M60	7 x 6	21,3	403,2	1110	10
46280G71070M61	7 x 10	25,6	672	1720	8
46280G71070M62	7 x 16	28,8	1075,2	2300	6
46280G71070M63	7 x 25	38,6	1680	3900	4
46280G71080M15	8 x 1,5	17,6	115,2	663	16
46280G71080M25	8 x 2,5	18,8	192	793	14
46280G71080M40	8 x 4	21,2	396,8	1030	12
46280G71080M60	8 x 6	24,1	460,8	1440	10
46280G71080M61	8 x 10	27,7	768	1960	8
46280G71100M15	10 x 1,5	19,8	144	812	16
46280G71100M25	10 x 2,5	21,4	240	989	14
46280G71100M40	10 x 4	25,1	384	1410	12
46280G71100M60	10 x 6	27,3	576	1680	10
46280G71100M61	10 x 10	31,5	960	2320	8
46280G71120M15	12 x 1,5	19,4	172,8	854	16
46280G71120M25	12 x 2,5	22,4	288	1080	14
46280G71120M40	12 x 4	27,7	460,8	1550	12
46280G71120M60	12 x 6	28	691,2	1920	10
46280G71120M61	12 x 10	32,3	1152	2660	8
46280G71160M15	16 x 1,5	21,9	230,4	1020	16
46280G71160M25	16 x 2,5	25	384	1430	14
46280G71160M40	16 x 4	29,1	614,4	1950	12
46280G71160M60	16 x 6	30,4	921,6	2300	10
46280G71190M15	19 x 1,5	23,2	273,6	1120	16
46280G71190M25	19 x 2,5	26,1	456	1570	14
46280G71190M40	19 x 4	29,3	729,6	2050	12
46280G71220M15	22 x 1,5	27,3	316,8	1560	16
46280G71220M25	22 x 2,5	29,7	528	1930	14
46280G71220M40	22 x 4	33,5	844,8	2530	12
46280G71270M15	27 x 1,5	27,9	388,8	1630	16
46280G71270M25	27 x 2,5	30,2	648	2050	14
46280G71270M40	27 x 4	34,2	1036,8	2740	12
46280G71300M15	30 x 1,5	28,5	432	1730	16
46280G71300M25	30 x 2,5	31,3	720	2200	14
46280G71370M15	37 x 1,5	30,6	532,8	1970	16
46280G71370M25	37 x 2,5	33,8	888	2540	14
46280G71370M40	37 x 4	39,6	1420,8	-	12
46280G71400M15	40 x 1,5	31,5	576	2080	16
46280G71400M25	40 x 2,5	35,9	960	2970	14
46280G71480M15	48 x 1,5	33,9	691,2	2390	16
46280G71480M25	48 x 2,5	38,8	1152	3430	14
46280G71480M40	48 x 4	44,6	1843,2	-	12

Other dimensions and colours available on request.

INDUSTRIAL LOW VOLTAGE CABLES

RE4(O)MI (XLPE/LS0H)



ELETTROTEK KABEL® RE4OM1

Construction:

- Conductor:** stranded red copper conductor Cl. 2, acc to IEC 60228
- Insulation:** XLPE compound
- Colour cores:** acc. to DIN VDE 0293-308, HD 308 S2 from 6 cores black cores with consecutive numbers acc. to EN 50334; green-yellow earth-wire from 3 cores
- Outer sheath:** black (RAL 9005), thermoplastic polyolefine compound

Resistance:



Self-extinguishing and flame retardant acc. to:
DIN VDE 0482 part 265-2-1
EN 50265-2-1
IEC 60332-1-2
IEC 60332-3-24



Halogen free acc. to:
DIN VDE 0482 part 267,
EN 50267-2-1
IEC 60754-1 (equivalent DIN VDE 0472 part 815)



Low smoke emission acc. to:
IEC 61034-1,
EN 50268-1,
DIN VDE 0482 part.268-1

Technical data:

- Nominal voltage:** 0,6/1 kV
- Test voltage:** 4 kV
- Temperature range**
- Fixed laying:* - 25 °C / + 90 °C
- Flexible application:* - 5 °C / + 90 °C
- Max short circuit temperature:** + 250 °C
- Min. bending radius:** 12 x d
- Max. tensile stress:** 50 N/mm²

Features:

according to IEC 60502-1

Part no.	No. of cores x cross section n x mm ²	Outer-Ø ca. mm ± 10%	Copper weight kg/km	Cable weight approx. kg/km	AWG no. *)
46290G7L010M40	1x4	6,5	38	65	12
46290G7L010M60	1x6	7	58	85	10
46290G7L010M61	1x10	8	96	125	8
46290G7L010M62	1x16	9	154	190	6
46290G7L010M63	1x25	11	240	300	4
46290G7L010M64	1x35	12	336	375	2
46290G7L010M65	1x50	14	480	500	1
46290G7L010M66	1x70	15	672	700	2/0
46290G7L010M67	1x95	17	912	950	3/0
46290G7L010M68	1x120	19	1152	950	4/0
46290G7L010M69	1x150	21	1440	1400	250 MCM
46290G7L010M70	1x185	23	1776	1800	350 MCM
46290G7L010M71	1x240	26	2304	-	450 MCM
46290G7L010M72	1x300	28	2880	3000	550 MCM
46290G7L010M73	1x400	32	3840	-	750 MCM
46290G7L010M74	1x500	36	4800	-	1000 MCM
46290G73020M15	2x1,5	11,1	29	180	16
46290G73020M25	2x2,5	11,9	48	210	14
46290G73020M40	2x4	12,7	77	270	12
46290G73020M60	2x6	13,7	115	340	10

INDUSTRIAL LOW VOLTAGE CABLES

RE4(O)MI (XLPE/LS0H)



ELETTROTEK KABEL® RE4OM1

Part no.	No. of cores x cross section n x mm ²	Outer-Ø ca. mm ± 10%	Copper weight kg/km	Cable weight approx. kg/km	AWG no. *)
46290G72031M15	3G1,5	11	43	135	16
46290G72031M25	3G2,5	11,5	72	175	14
46290G72031M40	3G4	12,5	115	225	12
46290G72031M60	3G6	13,5	173	300	10
46290G72031M61	3G10	15,5	288	430	8
46290G72031M62	3G16	18	461	650	6
46290G72031M63	3G25	22	720	950	4
46290G72031M64	3G35	24	1008	1250	2
46290G72031M65	3G50	27	1440	1700	1
46290G72031M66	3G70	31	2016	2450	2/0
46290G72031M67	3G95	35	2736	3300	3/0
46290G72031M68	3G120	39	3240	4100	4/0
46290G72031M69	3G150	43	4320	5050	150 MCM
46290G72031M70	3G185	48	5328	6250	250 MCM
46290G72031M71	3G240	54	6912	8150	500 MCM
46290G72031M72	3G300	60	8640	10200	600 MCM
46290G72031M73	3G400	67	11520	13000	750 MCM
46290G72035M62	3x16+1x10	19,5	556	750	8
46290G72035M63	3x25+1x16	23	873,6	1150	6
46290G72035M64	3x35+1x16	25	1161,6	1450	6
46290G72035M65	3x50+1x25	29	1680	2000	4
46290G72035M66	3x70+1x35	33	2016	2800	2
46290G72035M67	3x95+1x50	37	3408	3800	1
46290G72035M68	3x120+1x70	42	4128	4800	2/0
46290G72035M69	3x150+1x70	46	5232	5750	2/0
46290G72035M70	3x185+1x95	51	6240	7250	3/0
46290G72035M71	3x240+1x120	57	8352	9350	4/0
46290G72035M72	3x300+1x150	63	10080	11650	150 MCM
46290G72035M73	3x400+1x185	71	13296	14750	250 MCM
46290G72041M15	4G1,5	11,5	57,6	160	16
46290G72041M25	4G2,5	12,5	96	210	14
46290G72041M40	4G4	13,5	153,6	280	12
46290G72041M60	4G6	15	230,4	380	10
46290G72041M61	4G10	17	384	540	8
46290G72041M62	4G16	20	614,4	800	6
46290G72041M63	4G25	24	960	1250	4
46290G72041M64	4G35	26	1344	1650	2
46290G72041M65	4G50	30	1920	2250	1
46290G72041M66	4G70	35	2688	3150	2/0
46290G72041M67	4G95	39	3648	4200	3/0
46290G72041M68	4G120	44	4608	5300	4/0
46290G72041M69	4G150	48	5760	6500	150 MCM
46290G72041M70	4G185	53	7104	8100	250 MCM
46290G72041M71	4G240	60	9216	10500	500 MCM
46290G72041M72	4G300	66	11520	13100	600 MCM
46290G72041M73	4G400	75	15360	16750	750 MCM

INDUSTRIAL LOW VOLTAGE CABLES

RE4(O)MI (XLPE/LS0H)



ELETTROTEK KABEL® RE4OM1

Part no.	No. of cores x cross section n x mm ²	Outer-Ø ca. mm ± 10%	Copper weight kg/km	Cable weight approx. kg/km	AWG no. *)
46290G71070M10	7x1	12,2	67	210	17
46290G71100M10	10x1	14,7	96	310	17
46290G71180M10	18x1	17,5	172	460	17
46290G73050M15	5x1,5	12,7	72	206	16
46290G71070M15	7x1,5	13,1	100,8	243	16
46290G71100M15	10x1,5	13,8	144	287	16
46290G71120M15	12x1,5	15,2	172,8	328	16
46290G71190M15	19x1,5	17,3	273,6	484	16
46290G71240M15	24x1,5	20,2	345,6	603	16
46290G71070M25	7x2,5	13,5	168	310	14
46290G71100M25	10x2,5	15,9	240	472	14
46290G71120M25	12x2,5	17,3	288	540	14
46290G71190M25	19x2,5	21,3	456	840	14
46290G71240M25	24x2,5	24,6	576	1050	14
46290G73050M60	5x 6	16,6	260	500	10
46290G73050M63	5x25	26,1	1095	1600	4
46290G73050M64	5x35	29,3	1525	2110	2
46290G73050M67	5x95	43,8	4135	5360	3/0

Other dimensions and colours available on request.

INDUSTRIAL LOW VOLTAGE CABLES

RE4(O)FMI (XLPE/LS0H/SWA/LS0H)



ELETTROTEK KABEL® RE4OFM1



Construction:

Conductor:	stranded red copper conductor Cl. 2, acc to IEC 60228
Insulation:	XLPE compound
Colour cores:	acc. to DIN VDE 0293-308, HD 308 S2 from 6 cores black cores with consecutive numbers acc. to EN 50334; green-yellow earth-wire from 3 cores
Inner sheath:	thermoplastic, halogen free compound
Armour:	steel wires
Outer sheath:	black (RAL 9005), halogen free compound

Technical data:

Nominal voltage:	0,6/1 kV
Test voltage:	4 kV
Temperature range:	- 0 °C / + 90 °C
Max short circuit temperature:	+ 250 °C
Min. bending radius:	8 x d

Resistance:



Self-extinguishing and flame retardant acc. to:

DIN VDE 0482 part 266-1
EN 50266-1
IEC 60332-1-2
IEC 60332-3-24



Halogen free acc. to:

acc. to DIN VDE 0482 part 267
EN 50267-2-1 /
IEC 60754-1 (equivalent DIN VDE 0472 part 815)



Low smoke emission acc. to:

IEC 61034-1
EN 50268-1
DIN VDE 0482 part.268-1

Features:

according to IEC 60502-1

Part no.	No. of cores x cross section n x mm ²	Outer-Ø ca. mm ± 10%	Copper weight kg/km	Cable weight approx. kg/km	AWG no. *)
46300G7L010M65	1x50	19,7	480	850	1
46300G7L010M66	1x70	21,6	672	1080	2/0
46300G7L010M67	1x95	23,2	912	1360	3/0
46300G7L010M68	1x120	25,0	1152	1630	4/0
46300G7L010M69	1x150	26,8	1440	1940	250 MCM
46300G7L010M70	1x185	28,6	1776	2320	350 MCM
46300G7L010M71	1x240	31,7	2304	2920	450 MCM
46300G7L010M72	1x300	34,2	2880	3580	550 MCM
46300G7L010M73	1x400	37,6	3840	4490	750 MCM
46300G7L010M74	1x500	41,5	4800	5630	1000 MCM
46300G7L010M75	1x630	45,8	6048	7140	1250 MCM
46300G73020M15	2x1,5	13,3	28,8	330	16
46300G73020M25	2x2,5	14	48	370	14
46300G73020M40	2x4	15,1	76,8	440	12
46300G73020M60	2x6	16,2	115,2	530	10
46300G73020M61	2x10	18,5	192	800	8
46300G73020M62	2x16	20,4	307,2	1010	6
46300G73020M63	2x25	24,3	480	1510	4
46300G73020M64	2x35	26,4	672	1820	2
46300G73020M65	2x50	28,9	960	2230	1
46300G73020M66	2x70	33,1	1344	2930	2/0
46300G73020M67	2x95	37,7	1824	3990	3/0
46300G73020M68	2x120	41,5	2304	4810	4/0
46300G73020M69	2x150	45,3	2880	5690	150 MCM
46300G73020M70	2x185	50,8	3552	7300	250 MCM

INDUSTRIAL LOW VOLTAGE CABLES

RE4(O)FMI (XLPE/LS0H/SWA/LS0H)



ELETTROTEK KABEL® RE40FM1

Part no.	No. of cores x cross section n x mm ²	Outer-Ø ca. mm ± 10%	Copper weight kg/km	Cable weight approx. kg/km	AWG no. *)
46300G72031M15	3G1,5	13,7	43,2	360	16
46300G72031M25	3G2,5	14,6	72	410	14
46300G72031M40	3G4	15,7	115,2	500	12
46300G72031M60	3G6	16,9	172,8	600	10
46300G72031M61	3G10	19,3	288	910	8
46300G72031M62	3G16	21,3	460,8	1170	6
46300G72031M63	3G25	25,6	720	1760	4
46300G72031M64	3G35	27,8	1008	2160	2
46300G72031M65	3G50	30,7	1440	2700	1
46300G72031M66	3G70	36,2	2016	3850	2/0
46300G72031M67	3G95	40	2736	4880	3/0
46300G72031M68	3G120	44,1	3456	5900	4/0
46300G72031M69	3G150	49,8	4320	7550	150 MCM
46300G72031M70	3G185	54	5328	9010	250 MCM
46300G72041M15	4G1.5	14,5	57,6	400	16
46300G72041M25	4G2.5	15,4	96	460	14
46300G72041M40	4G4	16,8	153,6	570	12
46300G72041M60	4G6	19	230,4	830	10
46300G72041M61	4G10	20,6	384	1060	8
46300G72041M62	4G16	23,6	614,4	1510	6
46300G72041M63	4G25	27,6	960	2080	4
46300G72041M64	4G35	30,3	1344	2610	2
46300G72041M65	4G50	33,5	1920	3270	1
46300G72041M66	4G70	39,7	2688	4680	2/0
46300G72041M67	4G95	43,8	3648	5970	3/0
46300G72041M68	4G120	49,9	4608	7770	4/0
46300G72041M69	4G150	54,4	5760	9240	150 MCM
46300G72041M70	4G185	59,3	7104	11090	250 MCM
46300G72035M64	3x35+1x25	29,5	1248	2460	4
46300G72035M65	3x50+1x25	32,1	1680	2960	4
46300G72035M66	3x70+1x35	37,9	2352	4220	2
46300G72035M67	3x95+1x70	41,8	3408	5350	1
46300G72035M68	3x120+1x70	46,5	4128	6610	1
46300G72035M69	3x150+1x95	52,4	5232	8510	2/0
46300G72035M70	3x185+1x95	56,3	6240	9920	2/0
46300G72035M71	3x240+1x150	64,5	8352	12840	3/0
46300G72035M72	3x300+1x150	69	10080	15110	3/0
46300G73050M15	5x1,5	12,7	72	206	16
46300G71070M15	7x1,5	13,1	100,8	243	16
46300G71100M15	10x1,5	13,8	144	287	16
46300G71120M15	12x1,5	15,2	172,8	328	16
46300G71190M15	19x1,5	17,3	273,6	484	16
46300G71240M15	24x1,5	20,2	345,6	603	16
46300G71070M25	7x2,5	13,5	168	310	14
46300G71100M25	10x2,5	15,9	240	472	14
46300G71120M25	12x2,5	17,3	288	540	14
46300G71190M25	19x2,5	21,3	456	840	14
46300G71240M25	24x2,5	24,6	576	1050	14

Other dimensions and colours available on request.

INDUSTRIAL LOW VOLTAGE CABLES

N2XH



CE

ELETTROTEK KABEL® N2XH

Construction:

Conductor:	plain Cu wire conductor, single or multiple wire, according to DIN VDE 0295 cl.1 and IEC 60228cl. 1 or 2, HD 38
Insulation:	Halogen-free core insulation, cross-linked polyethylene compound 2X11, to HD 604 S
Colour cores:	acc. to DIN VDE 0293-308, HD 308 S2 from 6 cores black cores with consecutive numbers acc. to EN 50334; green-yellow earth-wire from 3 cores
Stranding:	cores stranded in layers
Wrapping:	filling compound or wrapped tape
Outer sheath:	black (RAL 9005), thermoplastic polyolefine compound HM4 to HD 604 S1

Resistance:



Flame retardant acc. to:
DIN VDE 0482 part 266-2-4
EN 50266-2-4
IEC 60332-3-24



Halogen free acc. to:
DIN VDE 0482 part 267,
EN 50267-2-1
IEC 60754-1 (equivalent DIN VDE 0472 part 815)



Corrosiveness of conflagration gases acc. to:
DIN VDE 0482 part 267
EN 50267-2-2
IEC 60754-2 (equivalent DIN VDE 0472 part 813)



Smoke density acc. to:
IEC 61034-1-2,
DIN VDE 0482 part. 268-1-2,
EN 50268-1-2

Technical data:

Nominal voltage:	0,6/1 kV
Test voltage:	4 kV
Highest voltage:	Um 1,2 kV
Temperature range	
<i>fixed laying:</i>	- 30 °C / + 90 °C
<i>flexible application:</i>	- 5 °C / + 70 °C
Max short circuit temperature:	+ 250 °C
Min. bending radius	
<i>Single core:</i>	12 x d
<i>Multi cores:</i>	15 x d
Radiation resistance:	up to 100x10 ⁶ cJ/kg

Features:

according to IEC 60502-1

UV resistance



re: circular solid conductor



rm: circular stranded conductor



sm: sector-shaped stranded conductor



se: sector-shaped solid conductor

INDUSTRIAL LOW VOLTAGE CABLES

N2XH



CE

ELETTROTEK KABEL® N2XH

Part no.	No. of cores x cross section n x mm ²	Outer-Ø ca. mm ± 10%	Copper weight kg/km	Cable weight approx. kg/km	AWG no. *)
46310G7L010M40	1x4 re	8	39	68	12
46310G7L010M60	1x6 re	9	58	90	10
46310G7L010M61	1x10 re	9	96	140	8
46310G7L010M62	1x16 rm	10	154	190	6
46310G7L010M63	1x25 rm	11	240	290	4
46310G7L010M64	1x35 rm	12	336	390	2
46310G7L010M65	1x50 rm	15	480	510	1
46310G7L010M66	1x70 rm	17	672	710	2/0
46310G7L010M67	1x95 rm	19	912	960	3/0
46310G7L010M68	1x120 rm	21	1152	1200	4/0
46310G7L010M69	1x150 rm	23	1440	1480	250 MCM
46310G7L010M70	1x185 rm	25	1776	1910	350 MCM
46310G7L010M71	1x240 rm	28	2304	2370	450 MCM
46310G7L010M72	1x300 rm	30	2880	2970	550 MCM
46310G7L010M73	1x400 rm	32	3840	4420	750 MCM
46310G7L010M74	1x500 rm	37	4800	4866	1000 MCM
46310G73020M15	2x1,5 re	12	29	185	16
46310G73020M25	2x2,5 re	12,2	48	220	14
46310G73020M40	2x4 re	13,2	77	275	12
46310G73020M60	2x6 re	14,1	115	335	10
46310G73020M61	2x10 re	16,2	192	450	8
46310G73020M62	2x16 re	17,8	307	620	6
46310G73020M63	2x25 rm	21	480	930	4
46310G72031M15	3G1,5 re	13	43	220	16
46310G72031M25	3G2,5 re	14	72	280	14
46310G72031M40	3G4 re	15	115	350	12
46310G72031M60	3G6 re	16	173	420	10
46310G72031M61	3G10 re	18	288	600	8
46310G72031M62	3G16 re	20	461	770	6
46310G72031M63	3G25 rm	21,8	720	1120	4
46310G72031M64	3G35 rm	24,9	1008	1550	2
46310G72031M65	3G50 rm	25,2	1440	1750	1
46310G72031M66	3G70 rm	29,2	2016	2450	2/0
46310G72031M67	3G95 rm	32	2736	3250	3/0
46310G72031M68	3G120 rm	34,9	3456	4000	4/0
46310G72031M69	3G150 rm	39,2	4320	5000	250 MCM
46310G72031M70	3G185 rm	44,1	5328	6150	350 MCM
46310G72031M71	3G240 rm	49,2	6912	8000	450 MCM
46310G72041M15	4G1,5 re	13	58	235	16
46310G72041M25	4G2,5 re	14	96	290	14
46310G72041M40	4G4 re	15	154	370	12
46310G72041M60	4G6 re	16	253	470	10
46310G72041M61	4G10 re	18	384	670	8
46310G72041M62	4G16 re	20	614	930	6
46310G72041M63	4G25 rm	25	960	1440	4
46310G72041M64	4G35 rm	27	1344	1890	2
46310G72041M65	4G50 rm	28	1920	2300	1
46310G72041M66	4G70 rm	32	2668	3200	2/0
46310G72041M67	4G95 rm	36	3648	4250	3/0
46310G72041M68	4G120 rm	40,2	4608	5350	4/0
46310G72041M69	4G150 rm	45,8	5760	6550	250 MCM
46310G72041M70	4G185 rm	49,5	7104	8100	350 MCM
46310G72041M71	4G240 rm	56	9216	10550	450 MCM

INDUSTRIAL LOW VOLTAGE CABLES

N2XH



CE

ELETTROTEK KABEL® N2XH

Part no.	No. of cores x cross section n x mm ²	Outer-Ø ca. mm ± 10%	Copper weight kg/km	Cable weight approx. kg/km	AWG no. *)
46310G72051M15	5G1,5 re	14,5	72	280	16
46310G72051M25	5G2,5 re	16	120	350	14
46310G72051M40	5G4 re	17	192	450	12
46310G72051M60	5G6 re	18,5	288	600	10
46310G72051M61	5G10 re	21	480	850	8
46310G72051M62	5G16 re	24	768	1200	6
46310G70071M15	7G1,5 re	15,5	101	350	16
46310G70071M25	7G2,5 re	17	168	370	14
46310G70071M40	7G4 re	17,2	269	530	12
46310G70101M15	10G1,5 re	18,5	144	480	16
46310G70101M25	10G2,5 re	20	240	500	14
46310G70121M15	12G1,5 re	19	173	520	16
46310G70121M25	12G2,5 re	21	288	560	14
46310G70121M40	12G4 re	21,2	461	800	12
46310G70141M15	14G1,5 re	20	202	550	16
46310G70141M25	14G2,5 re	22	336	630	14
46310G70191M15	19G1,5 re	22	274	700	16
46310G70191M25	19G2,5 re	24	456	800	14
46310G70241M15	24G1,5 re	25	346	850	16
46310G70241M25	24G2,5 re	27	576	990	14
46310G70301M15	30G1,5 re	26	432	950	16
46310G70301M25	30G2,5 re	28	720	1180	14

3+1/2 conductors

Part no.	No. of cores x cross section n x mm ²	Outer-Ø ca. mm ± 10%	Copper weight kg/km	Cable weight approx. kg/km	AWG no. *)
46310G72035M65	3X50/25 rm	28,5	1680	2300	1
46310G72035M66	3X70/35 rm	31,4	2352	2800	2/0
46310G72035M67	3X95/50 rm	34,9	3216	3800	3/0
46310G72035M68	3X120/70 rm	38	4128	4700	4/0
46310G72035M69	3X150/70	43,3	4992	5600	250 MCM
46310G72035M70	3X185/95	47,2	6240	7400	350 MCM
46310G72035M71	3X240/120	53,4	8064	9600	450 MCM

Other dimensions and colours available on request.

INDUSTRIAL LOW VOLTAGE CABLES

N2XCH



CE

ELETTROTEK KABEL® N2XCH

Construction:

Conductor:	plain Cu wire conductor, single or multiple wire, according to DIN VDE 0295 cl.1 and IEC 60228cl. 1 or 2, HD 38
Insulation:	Halogen-free core insulation, cross-linked polyethylene compound 2X11, to HD 604 S
Colour cores:	acc. to DIN VDE 0293-308, HD 308 S2 from 6 cores black cores with consecutive numbers acc. to EN 50334
Stranding:	cores stranded in layers
Wrapping:	filling compound or wrapped tape
Screen:	concentric conductor of plain Copper wires
Outer sheath:	black (RAL 9005), thermoplastic polyolefine compound HM4 to HD 604 S1

Resistance:



Flame retardant acc. to:
DIN VDE 0482 part 266-2-4
EN 50266-2-4
IEC 60332-3-24



Halogen free acc. to:
DIN VDE 0482 part 267
EN 50267-2-1 /
IEC 60754-1 (equivalent DIN VDE 0472 part 815)



Corrosiveness of conflagration gases acc. to:
DIN VDE 0482 part 267
EN 50267-2-2 /
IEC 60754-2 (equivalent DIN VDE 0472 part 813)



Smoke density acc. to:
IEC 61034-1-2
DIN VDE 0482 part. 268-1-2,
EN 50268-1-2

Technical data:

Nominal voltage:	0,6/1 kV
Test voltage:	4 kV
Highest voltage:	Um 1,2 kV
Temperature range	
<i>fixed laying:</i>	- 30 °C / + 90 °C
<i>flexible application:</i>	- 5 °C / + 70 °C
Max short circuit temperature:	+ 250 °C
Min. bending radius:	12 x d
Radiation resistance:	up to 100x10 ⁶ cJ/kg

Features:

according to IEC 60502-1

UV resistance



re: circular solid conductor



rm: circular stranded conductor



sm: sector-shaped stranded conductor



se: sector-shaped solid conductor

INDUSTRIAL LOW VOLTAGE CABLES

N2XCH



CE

ELETTROTEK KABEL® N2XCH

Part no.	No. of cores x cross section n x mm ²	Outer-Ø ca. mm ± 10%	Copper weight kg/km	Cable weight approx. kg/km	AWG no. *)
46320G73020M15	2x1,5/1,5 re	14	53	250	16
46320G73020M25	2x2,5/2,5 re	15	81,1	280	14
46320G73020M40	2x4/4 re	14	122	320	12
46320G73020M60	2x6/6 re	15	183	400	10
46320G73020M61	2x10/10 re	16	311	560	8
46320G73020M62	2x16/16 re	19,1	490	780	6
46320G73030M15	3x1,5/1,5 re	14,5	67	250	16
46320G73030M25	3x2,5/2,5 re	15,5	104	320	14
46320G73030M40	3x4/4 re	16,5	161	400	12
46320G73030M60	3x6/6 re	18	242	500	10
46320G73030M61	3x10/10 re	20	408	750	8
46320G73030M62	3x16/16 re	22,5	643	1000	6
46320G73030M63	3x25/16 re	27	1001	1600	4
46320G73030M64	3x35/16 re	27,5	1190	1900	2
46320G73030M65	3x50/25 re	32,3	2003	2400	1
46320G73030M66	3x70/35 re	35,6	2794	3060	2/0
46320G73030M67	3x95/50 re	39	3790	4200	3/0
46320G73030M68	3x120/70 re	42	4785	5207	4/0
46320G73030M69	3x150/70 re	43,5	5100	5700	250 MCM
46320G73030M70	3x185/95 re	47,4	6381	7150	350 MCM
46320G73030M71	3x240/120 re	53,5	8240	9250	450 MCM
46320G73040M15	4x1,5/1,5 re	15,5	81	300	16
46320G73040M25	4x2,5/2,5 re	16,5	129	380	14
46320G73040M40	4x4/4 re	17,5	202	480	12
46320G73040M60	4x6/6 re	19	297	600	10
46320G73040M61	4x10/10 re	21,5	504	850	8
46320G73040M62	4x16/16 re	24,5	797	1200	6
46320G73040M63	4x25/16 rm	29	1142	1800	4
46320G73040M64	4x35/16 rm	29,5	1528	2100	2
46320G73040M65	4x50/25 rm	32,5	2203	2800	1
46320G73040M66	4x70/35 rm	38	3082	3800	2/0
46320G73040M67	4x95/50 rm	43,5	4208	5100	3/0
46320G73040M68	4x120/70 rm	50,5	5382	6556	4/0
46320G73040M69	4x150/70 rm	52,1	6540	7600	250 MCM
46320G73040M70	4x185/95 rm	57,2	8159	9370	350 MCM
46320G73040M71	4x240/120 re	62,6	10546	11611	450 MCM
46320G70070M15	7x1,5/2,5 re	14,5	132	320	16
46320G70070M25	7x2,5/2,5 re	15,1	200	400	14
46320G70070M40	7x4/4 re	18,1	316	580	12
46320G70100M15	10x1,5/2,5 re	17,2	177	420	16
46320G70100M25	10x2,5/4 re	18,9	287	550	14
46320G70120M15	12x1,5/2,5 re	18,4	204	460	16
46320G70120M25	12x2,5/4 re	19,2	335	610	14
46320G70120M40	12x4/6 re	22,6	528	910	12
46320G70160M15	16x1,5/4 re	20	275	686	16
46320G70160M25	16x2,5/6 re	20,9	450	805	14
46320G70210M15	21x1,5/6 re	22,6	370	766	16
46320G70210M25	21x2,5/6 re	25,2	572	1015	14
46320G70240M15	24x1,5/6 re	23,2	412	800	16
46320G70240M25	24x2,5/10 re	26,1	695	1100	14
46320G70300M15	30x1,5/6 re	24,3	500	930	16
46320G70300M25	30x2,5/10 re	28	842	1290	14

Other dimensions and colours available on request.

INDUSTRIAL LOW VOLTAGE CABLES

GAALFLEX® CONTROL 07BQ-F

PUR power cable, single core, 450/750 V



Construction:

Conductor:	flexible red copper conductor Cl. 5, acc to IEC 60228, DIN VDE 0295
Insulation:	rubber compound
Colour cores:	acc. to DIN VDE 0293-308, HD 308 S2
Stranding:	in layers
Outer sheath:	orange (RAL 2003),PUR

Features:

- Chemical resistant
- UV resistant
- Abrasion resistant

Technical data:

Nominal voltage:	450/750 V
Test voltage:	2,5 kV
Temperature range	
<i>fixed laying:</i>	- 40 °C / + 90 °C
<i>flexible application:</i>	- 40 °C / + 90 °C
Min. bending radius:	10 x d
Insulation resistance:	min. 20 MΩ x km

Applications:

Connecting cable used in hand-held electric tools, for flexible and fixed installation. Suitable in dry, humid or wet rooms. Outdoor use within temperature range, no laying underground

Part no.	No. of cores x cross section n x mm ²	Outer-Ø ca. mm ± 10%	Copper weight kg/km	Cable weight approx. kg/km	AWG no. *)
31310EGL010M62	1x16	10,8	153,6	230	6
31310EGL010M63	1x25	12,8	240	350	4
31310EGL010M64	1x35	15,3	336	484	2
31310EGL010M65	1x50	16,8	480	620	1
31310EGL010M66	1x70	19	672	830	2/0
31310EGL010M67	1x95	21,8	912	1130	3/0
31310EGL010M68	1x120	24,3	1152	1390	4/0
31310EGL010M69	1x150	26,6	1440	1710	250 MCM
31310EGL010M70	1x185	29,2	1776	2130	350 MCM
31310EGL010M71	1x240	33	2304	2720	450 MCM
31310EGL010M72	1x300	35	2880	3140	550 MCM

Other dimensions and colours available on request.

* Black or green/yellow insulation

L: black
PE: green/yellow.

INDUSTRIAL LOW VOLTAGE CABLES

GAALFLEX® CONTROL (H)07BQ-F

PUR power cable, multi core, 450/750 V



Construction:

Conductor:	flexible red copper conductor Cl. 5, acc to IEC 60228, DIN VDE 0295
Insulation:	rubber compound
Colour cores:	acc. to DIN VDE 0293-308, HD 308 S2 green-yellow earth-wire from 3 cores
Stranding:	in layers
Outer sheath:	orange (RAL 2003),PUR

Technical data:

Nominal voltage:	450/750 V
Test voltage:	2,5 kV
Temperature range	
<i>fixed laying:</i>	- 40 °C / + 90 °C
<i>flexible application:</i>	- 40 °C / + 90 °C
Min. bending radius:	4 x d
Insulation resistance:	min. 20 MΩ x km

Features:

Chemical resistant
UV resistant
Abrasion resistant
acc. to standard HD 22.10.S1 and DIN VDE 0282 T10
acc. to HAR HD 22.10.S1 (H07BQ-F)

Applications:

Connecting cable used in hand-held electric tools, for flexible and fixed installation. Suitable in dry, humid or wet rooms. Outdoor use within temperature range, no laying underground

Part no.	No.of cores x cross section n x mm ²	Outer-Ø ca.mm ± 10%	Copper weight kg/km	Cable weight approx. kg/km	AWG no.®)
31310EG3020M15	2 x 1,5	8,8	28,8	115	16
31310EG2031M15	3 G 1,5	9,3	43,2	135	16
31310EG2041M15	4 G 1,5	10,5	57,6	165	16
31310EG2051M15	5 G 1,5	11,5	72	200	16
31310EG2031M25	3 G 2,5	11,2	72	190	14
31310EG2041M25	4 G 2,5	12,5	96	230	14
31310EG2051M25	5 G 2,5	13,8	120	290	14
31310EG2041M40	4 G 4	14,7	153,6	325	12
31310EG2051M40	5 G 4	16,2	192	400	12
31310EG2041M60	4 G 6	16,4	230,4	350	10
31310EG2051M60	5 G 6	18,1	288	520	10
31310EG2041M61	4 G 10	21,3	384	730	8
31310EG2051M61	5 G 10	23,4	480	900	8
31310EG2041M62	4 G16	24,4	614,4	1020	6
31310EG2051M62	5 G16	27,2	768	1260	6
31310EG2041M63	4G25	29,5	960	1229	4
31310EG2051M63	5G25	35	1200	1535	4
31310EG2041M64	4G35	33,5	1344	1665	2
31310EG2051M64	5G35	39	1680	2103	2
31310EG2041M65	4G50	39,4	1920	2341	1
31310EG2051M65	5G50	47	2400	2955	1
31310EG2041M66	4G70	49	2688	3259	2/0
31310EG2051M66	5G70	53	3360	4001	2/0
31310EG2051M67	5G95	60	4560	5369	3/0

Other dimensions and colours available on request.



INDUSTRIAL MEDIUM VOLTAGE CABLES



INDUSTRIAL MEDIUM VOLTAGE CABLES

RG7HIR



Construction:

Conductor:	stranded red copper conductor Cl.2 acc.to IEC 60228
Insulation:	rubber,type G7
Screen:	red copper tape
Outer sheath:	red (RAL 3000),PVC,type RZ

Resistance:



Flame retardant acc. to:
DIN VDE 0482 part 265-2-1
EN 50265-2-1
EN 60332-1-2

Technical data:

Nominal voltage:	1,8/3 kV, 3,6/6 kV, 6/10 kV 8,7/15 kV, 12/20 kV 18/30 kV, 26/45 kV
Test voltage:	1,8/3 kV = 6 kV 8,7/15 kV = 24 kV 3,6/6 kV = 11 kV 12/20 kV = 29 kV 6/10 kV = 17 kV 18/30 kV = 45 kV
Temperature range:	- 15 °C / + 90 °C
Max short circuit temperature:	+ 250 °C
Min installation temperature:	0 °C
Min. bending radius:	12 x d
Max. tensile stress:	60 N/mm ²

Features:

according to IEC 60502-2

1,8/3 kV

Part no.	No.of cores x cross section n x mm ²	Outer-Ø ca.mm ± 10%	Cable weight approx. kg/km	AWG no.*)
48010KRL010M61	1x10	14,5	290	8
48010KRL010M62	1x16	15,2	350	6
48010KRL010M63	1x25	16,5	450	4
48010KRL010M64	1x35	17,5	550	2
48010KRL010M65	1x50	18,5	670	1
48010KRL010M66	1x70	20	880	2/0
48010KRL010M67	1x95	22	1100	3/0
48010KRL010M68	1x120	23,3	1400	4/0
48010KRL010M69	1x150	24,7	1650	250 MCM
48010KRL010M70	1x185	26,5	2000	350 MCM
48010KRL010M71	1x240	29	2550	450 MCM
48010KRL010M72	1x300	31,6	3150	550 MCM
48010KRL010M73	1x400	34,6	3950	750 MCM
48010KRL010M74	1x500	38,3	5050	900 MCM
48010KRL010M75	1x630	43,1	6300	1150 MCM

INDUSTRIAL MEDIUM VOLTAGE CABLES

RG7HIR



3,6/6 kV

Part no.	No. of cores x cross section n x mm ²	Outer-Ø ca. mm ± 10%	Cable weight approx. kg/km	AWG no.®)
48010MRL010M61	1x10	17	330	8
48010MRL010M62	1x16	17,5	410	6
48010MRL010M63	1x25	18,8	510	4
48010MRL010M64	1x35	19,8	630	2
48010MRL010M65	1x50	21,4	750	1
48010MRL010M66	1x70	23,3	1010	2/0
48010MRL010M67	1x95	24,8	1250	3/0
48010MRL010M68	1x120	26,3	1500	4/0
48010MRL010M69	1x150	27,8	1800	250 MCM
48010MRL010M70	1x185	29,5	2100	350 MCM
48010MRL010M71	1x240	32,1	2650	450 MCM
48010MRL010M72	1x300	34,8	3200	550 MCM
48010MRL010M73	1x400	37,8	4000	750 MCM
48010MRL010M74	1x500	41,8	5100	900 MCM
48010MRL010M75	1x630	45,8	6500	1150 MCM

6/10 kV

Part no.	No. of cores x cross section n x mm ²	Outer-Ø ca. mm ± 10%	Cable weight approx. kg/km	AWG no.®)
48010QRL010M61	1x10	19,9	420	8
48010QRL010M62	1x16	20,4	530	6
48010QRL010M63	1x25	21,8	650	4
48010QRL010M64	1x35	23,3	760	2
48010QRL010M65	1x50	24,8	880	1
48010QRL010M66	1x70	26,3	1100	2/0
48010QRL010M67	1x95	27,8	1400	3/0
48010QRL010M68	1x120	29,3	1630	4/0
48010QRL010M69	1x150	30,8	1900	250 MCM
48010QRL010M70	1x185	32,8	2350	350 MCM
48010QRL010M71	1x240	35,3	2900	450 MCM
48010QRL010M72	1x300	37,8	3500	550 MCM
48010QRL010M73	1x400	40,8	4300	750 MCM
48010QRL010M74	1x500	44,3	5420	900 MCM
48010QRL010M75	1x630	54,8	6850	1150 MCM

8,7/15 kV

Part no.	No. of cores x cross section n x mm ²	Outer-Ø ca. mm ± 10%	Cable weight approx. kg/km	AWG no.®)
48010SRL010M62	1x16	23	650	6
48010SRL010M63	1x25	24,3	750	4
48010SRL010M64	1x35	25,3	850	2
48010SRL010M65	1x50	26,3	1000	1
48010SRL010M66	1x70	28,3	1220	2/0
48010SRL010M67	1x95	30,3	1500	3/0
48010SRL010M68	1x120	31,9	1900	4/0
48010SRL010M69	1x150	33,3	2100	250 MCM
48010SRL010M70	1x185	35,3	2500	350 MCM
48010SRL010M71	1x240	38,3	3030	450 MCM
48010SRL010M72	1x300	40,3	3800	550 MCM
48010SRL010M73	1x400	43,3	4600	750 MCM
48010SRL010M74	1x500	47,3	5700	900 MCM
48010SRL010M75	1x630	52,3	7100	1150 MCM

INDUSTRIAL MEDIUM VOLTAGE CABLES

RG7HIR



12/20 kV

Part no.	No. of cores x cross section n x mm ²	Outer-Ø ca. mm ± 10%	Cable weight approx. kg/km	AWG no. *)
48010URL010M64	1x35	27,3	960	2
48010URL010M65	1x50	28,5	1100	1
48010URL010M66	1x70	30,4	1350	2/0
48010URL010M67	1x95	32,4	1650	3/0
48010URL010M68	1x120	33,9	1950	4/0
48010URL010M69	1x150	35,2	2300	250 MCM
48010URL010M70	1x185	37	2600	350 MCM
48010URL010M71	1x240	39,5	3200	450 MCM
48010URL010M72	1x300	42	3900	550 MCM
48010URL010M73	1x400	45,3	4800	750 MCM
48010URL010M74	1x500	49	5900	900 MCM
48010URL010M75	1x630	53,7	7300	1150 MCM

18/30 kV

Part no.	No. of cores x cross section n x mm ²	Outer-Ø ca. mm ± 10%	Cable weight approx. kg/km	AWG no. *)
48010XRL010M65	1x50	35,9	1400	1
48010XRL010M66	1x70	36,1	1700	2/0
48010XRL010M67	1x95	37,8	1950	3/0
48010XRL010M68	1x120	39,1	2230	4/0
48010XRL010M69	1x150	40,7	2550	250 MCM
48010XRL010M70	1x185	42,6	3000	350 MCM
48010XRL010M71	1x240	45,3	3600	450 MCM
48010XRL010M72	1x300	47,8	4300	550 MCM
48010XRL010M73	1x400	51,2	5200	750 MCM
48010XRL010M74	1x500	55	6300	900 MCM
48010XRL010M75	1x630	61,9	7800	1150 MCM

26/45 kV

Part no.	No. of cores x cross section n x mm ²	Outer-Ø ca. mm ± 10%	Cable weight approx. kg/km	AWG no. *)
48010ZRL010M66	1x70	43	2150	2/0
48010ZRL010M67	1x95	44	2490	3/0
48010ZRL010M68	1x120	45,6	2735	4/0
48010ZRL010M69	1x150	46	3020	250 MCM
48010ZRL010M70	1x185	47	3395	350 MCM
48010ZRL010M71	1x240	49,5	4025	450 MCM
48010ZRL010M72	1x300	53	4725	550 MCM
48010ZRL010M73	1x400	56	5635	750 MCM
48010ZRL010M74	1x500	59	6825	900 MCM
48010ZRL010M75	1x630	64	8260	1150 MCM

* For cables laying in earth a screen-cross section of 16 mm is permitted.

Other dimensions and colours available on request.

INDUSTRIAL MEDIUM VOLTAGE CABLES

RG7HI(O)R



ELETTROTEK KABEL® RG7H10R

Construction:

Conductor:	stranded red copper conductor Cl. 2, acc. to IEC 60228
Insulation:	rubber, type G7
Screen:	red copper tape
Inner sheath:	not hygroscopic filler
Outer sheath:	red (RAL 3000), PVC, type RZ

Resistance:



Flame retardant acc. to:
DIN VDE 0482 part 265-2-1
EN 50265-2-1
EN 60332-1-2

Technical data:

Nominal voltage:	1,8/3 kV, 3,6/6 kV, 6/10 kV 8,7/15 kV, 12/20 kV 18/30 kV, 26/45 kV
Test voltage:	1,8/3 kV = 6 kV 3,6/6 kV = 11 kV 6/10 kV = 17 kV 8,7/15 kV = 24 kV 12/20 kV = 29 kV 18/30 kV = 45 kV
Temperature range:	- 15 °C / + 90 °C
Max short circuit temperature:	+ 250 °C
Min installation temperature:	0 °C
Min. bending radius:	12 x d
Max. tensile stress:	60 N/mm ²

Features:

according to IEC 60502-2

1,8/3 kV

Part no.	No. of cores x cross section n x mm ²	Outer-Ø ca. mm ± 10%	Cable weight approx. kg/km	AWG no. *)
48010KR1030M61	3x10	27,2	904	8
48010KR1030M62	3x16	29,5	1155	6
48010KR1030M63	3x25	32,5	1575	4
48010KR1030M64	3x35	34,5	1952	2
48010KR1030M65	3x50	37,2	2332	1
48010KR1030M66	3x70	41,4	3150	2/0
48010KR1030M67	3x95	45	4024	3/0
48010KR1030M68	3x120	48,7	4918	4/0
48010KR1030M69	3x150	52,2	5791	250 MCM
48010KR1030M70	3x185	56,5	7086	350 MCM
48010KR1030M71	3x240	62	8975	450 MCM
48010KR1030M72	3x300	67,3	11069	550 MCM
48010KR1030M73	3x400	74,2	13756	750 MCM

3,6/6 kV

Part no.	No. of cores x cross section n x mm ²	Outer-Ø ca. mm ± 10%	Cable weight approx. kg/km	AWG no. *)
48010MR1030M61	3x10	31,8	1287	8
48010MR1030M62	3x16	34,4	1530	6
48010MR1030M63	3x25	37,4	1980	4
48010MR1030M64	3x35	39,7	2406	2
48010MR1030M65	3x50	42,8	2896	1
48010MR1030M66	3x70	46,3	3663	2/0
48010MR1030M67	3x95	50	4653	3/0
48010MR1030M68	3x120	54,2	5544	4/0
48010MR1030M69	3x150	57,3	6435	250 MCM
48010MR1030M70	3x185	61,5	7821	350 MCM
48010MR1030M71	3x240	66,8	9900	450 MCM
48010MR1030M72	3x300	72,9	12375	550 MCM
48010MR1030M73	3x400	78,2	15420	750 MCM

INDUSTRIAL MEDIUM VOLTAGE CABLES

RG7HI(O)R



ELETTROTEK KABEL® RG7H10R

6/10 kV

Part no.	No. of cores x cross section n x mm ²	Outer-Ø ca. mm ± 10%	Cable weight approx. kg/km	AWG no. *)
48010QR1030M61	3x10	36,9	1791	8
48010QR1030M62	3x16	39	2070	6
48010QR1030M63	3x25	42	2497	4
48010QR1030M64	3x35	44	2945	2
48010QR1030M65	3x50	47	3463	1
48010QR1030M66	3x70	51	4378	2/0
48010QR1030M67	3x95	55	5403	3/0
48010QR1030M68	3x120	57,1	6358	4/0
48010QR1030M69	3x150	62	7413	250 MCM
48010QR1030M70	3x185	66	8806	350 MCM
48010QR1030M71	3x240	72,1	10935	450 MCM
48010QR1030M72	3x300	77,8	13293	550 MCM
48010QR1030M73	3x400	85	16000	750 MCM

8,7/15 kV

Part no.	No. of cores x cross section n x mm ²	Outer-Ø ca. mm ± 10%	Cable weight approx. kg/km	AWG no. *)
48010SR1030M62	3x16	45,5	2567	6
48010SR1030M63	3x25	48	3025	4
48010SR1030M64	3x35	51,2	3512	2
48010SR1030M65	3x50	53,5	4109	1
48010SR1030M66	3x70	58	5035	2/0
48010SR1030M67	3x95	61,5	6119	3/0
48010SR1030M68	3x120	65	7094	4/0
48010SR1030M69	3x150	68,2	8199	250 MCM
48010SR1030M70	3x185	72,5	9652	350 MCM
48010SR1030M71	3x240	78,2	11860	450 MCM
48010SR1030M72	3x300	78,6	14185	550 MCM

12/20 kV

Part no.	No. of cores x cross section n x mm ²	Outer-Ø ca. mm ± 10%	Cable weight approx. kg/km	AWG no. *)
48010UR1030M64	3x35	57,6	4050	2
48010UR1030M65	3x50	60,1	4637	1
48010UR1030M66	3x70	64,5	5652	2/0
48010UR1030M67	3x95	69,5	6786	3/0
48010UR1030M68	3x120	74,8	7791	4/0
48010UR1030M69	3x150	75	8925	250 MCM
48010UR1030M70	3x185	80,3	10428	350 MCM
48010UR1030M71	3x240	84	12627	450 MCM
48010UR1030M72	3x300	91,5	15094	550 MCM

18/30 kV

Part no.	No. of cores x cross section n x mm ²	Outer-Ø ca. mm ± 10%	Cable weight approx. kg/km	AWG no. *)
48010XR1030M65	3x50	72	6420	1
48010XR1030M66	3x70	75,9	7500	2/0
48010XR1030M67	3x95	80,1	8740	3/0
48010XR1030M68	3x120	83,2	9840	4/0
48010XR1030M69	3x150	86,9	11070	250 MCM
48010XR1030M70	3x185	91	12730	350 MCM
48010XR1030M71	3x240	96,3	15060	450 MCM

* For cables laying in earth a screen-cross section of 16 mm is permitted.

Other dimensions and colours available on request.

RG7HI(O)NR



ELETTROTEK KABEL® RG7H10NR



Construction:

Conductor:	stranded red copper conductor Cl. 2, acc. to IEC 60228
Insulation:	rubber, type G7
Screen:	red copper tape
Inner sheath:	not hygroscopic filler
Armour:	steel tape
Outer sheath:	red (RAL 3000), PVC, type RZ

Resistance:



Flame retardant acc. to:
DIN VDE 0482 part 265-2-1
EN 50265-2-1
EN 60332-1-2

Technical data:

Nominal voltage:	1,8/3 kV, 3,6/6 kV, 6/10 kV 8,7/15 kV, 12/20 kV 18/30 kV, 26/45 kV
Test voltage:	1,8/3 kV = 6 kV 8,7/15 kV = 24 kV 3,6/6 kV = 11 kV 12/20 kV = 29 kV 6/10 kV = 17 kV 18/30 kV = 45 kV
Temperature range:	- 15 °C / + 90 °C
Max short circuit temperature:	+ 250 °C
Min installation temperature:	0 °C
Min. bending radius:	16 x d
Max. tensile stress:	60 N/mm ²

Features:

according to IEC 60502-2

1,8/3 kV

Part no.	No. of cores x cross section n x mm ²	Outer-Ø ca. mm ± 10%	Cable weight approx. kg/km	AWG no. *)
48020KR1030M61	3x10	30,5	1343	8
48020KR1030M62	3x16	32,5	1642	6
48020KR1030M63	3x25	35,5	1990	4
48020KR1030M64	3x35	37,5	2388	2
48020KR1030M65	3x50	40,5	2985	1
48020KR1030M66	3x70	44,5	3861	2/0
48020KR1030M67	3x95	48	4876	3/0
48020KR1030M68	3x120	52	5871	4/0
48020KR1030M69	3x150	55,5	6915	250 MCM
48020KR1030M70	3x185	59,5	8278	350 MCM
48020KR1030M71	3x240	65	10393	450 MCM
48020KR1030M72	3x300	70,5	13154	550 MCM
48020KR1030M73	3x400	77,5	15821	750 MCM

3,6/6 kV

Part no.	No. of cores x cross section n x mm ²	Outer-Ø ca. mm ± 10%	Cable weight approx. kg/km	AWG no. *)
48020MR1030M61	3x10	36	1525	8
48020MR1030M62	3x16	37,5	1812	6
48020MR1030M63	3x25	40,5	2267	4
48020MR1030M64	3x35	43	2723	2
48020MR1030M65	3x50	46	3544	1
48020MR1030M66	3x70	49,5	4455	2/0
48020MR1030M67	3x95	53,5	4554	3/0
48020MR1030M68	3x120	57,5	6336	4/0
48020MR1030M69	3x150	60,5	7623	250 MCM
48020MR1030M70	3x185	64,5	9009	350 MCM
48020MR1030M71	3x240	70	11187	450 MCM
48020MR1030M72	3x300	76	13662	550 MCM
48020MR1030M73	3x400	82,5	16731	750 MCM

INDUSTRIAL MEDIUM VOLTAGE CABLES

RG7HI(O)NR



ELETTROTEK KABEL® RG7H10NR

6/10 kV

Part no.	No. of cores x cross section n x mm ²	Outer-Ø ca. mm ± 10%	Cable weight approx. kg/km	AWG no. *)
4802QR1030M61	3x10	39,5	2607	8
4802QR1030M62	3x16	41,5	2965	6
4802QR1030M63	3x25	44,3	3453	4
4802QR1030M64	3x35	47,5	4040	2
4802QR1030M65	3x50	50	4617	1
4802QR1030M66	3x70	54,5	5622	2/0
4802QR1030M67	3x95	58,5	6746	3/0
4802QR1030M68	3x120	62	7831	4/0
4802QR1030M69	3x150	65,5	8965	250 MCM
4802QR1030M70	3x185	69	10408	350 MCM
4802QR1030M71	3x240	75,5	12756	450 MCM
4802QR1030M72	3x300	81,5	15258	550 MCM

12/20 kV

Part no.	No. of cores x cross section n x mm ²	Outer-Ø ca. mm ± 10%	Cable weight approx. kg/km	AWG no. *)
4802UR1030M64	3x35	58,3	5393	2
4802UR1030M65	3x50	61	6099	1
4802UR1030M66	3x70	65,5	7214	2/0
4802UR1030M67	3x95	69,5	8448	3/0
4802UR1030M68	3x120	73	9602	4/0
4802UR1030M69	3x150	76,5	10826	250 MCM
4802UR1030M70	3x185	80,5	12338	350 MCM
4802UR1030M71	3x240	86,8	14510	450 MCM
4802UR1030M72	3x300	93,5	17300	550 MCM

18/30 kV

Part no.	No. of cores x cross section n x mm ²	Outer-Ø ca. mm ± 10%	Cable weight approx. kg/km	AWG no. *)
4802XR1030M65	3x50	76	8210	1
4802XR1030M66	3x70	78	9460	2/0
4802XR1030M67	3x95	81	10810	3/0
4802XR1030M68	3x120	84,5	12080	4/0
4802XR1030M69	3x150	89	13420	250 MCM
4802XR1030M70	3x185	93	15070	350 MCM
4802XR1030M71	3x240	98	17550	450 MCM

26/45 kV

Part no.	No. of cores x cross section n x mm ²	Outer-Ø ca. mm ± 10%	Cable weight approx. kg/km	AWG no. *)
4802ZR1030M66	3x70	33,3	9157	2/0
4802ZR1030M67	3x95	35	10500	3/0
4802ZR1030M68	3x120	37	11980	4/0
4802ZR1030M69	3x150	37	12450	250 MCM
4802ZR1030M70	3x185	39	13990	350 MCM

* For cables laying in earth a screen-cross section of 16 mm is permitted.

Other dimensions and colours available on request.

INDUSTRIAL MEDIUM VOLTAGE CABLES

ARG7HIE

Single-core, overall copper wires and tape screen 12/20 kV up to 18/30 kV



Construction:

Conductor:	stranded plain aluminium conductor Cl.2, acc. to IEC 60228
Insulation:	special EPR type DIH2
Inner semi-conductive layer:	extruded compound
Outer semi-conductive layer:	strippable cold extruded compound
Screen:	red copper wires and one or two copper tape(s) applied helically
Outer sheath:	red(RAL 3000),PE type DMZ1

Resistance:



Self-extinguishing and flame retardant acc. to:
DIN VDE 0482 part 265-2-1
EN 50265-2-1
IEC 60332-1

Technical data:

Nominal voltage:	12/20 kV up to 18/30 kV
Test voltage:	12/20 kV = 29 kV 18/30 kV = 43 kV
Temperature range:	- 25 °C / + 105 °C
Max short circuit temperature:	+ 300 °C
Min. bending radius:	13 x d
Max. tensile stress:	60 N/mm ²

Features:

according to IEC 60502-2

12/20 kV

Part no.	No. of cores x cross section n x mm ²	Outer-Ø ca. mm ± 10%	Cable weight approx. kg/km	AWG no. *)
48040URL010M63	1 x 35	26,1	570	2
48040URL010M64	1 x 50	26,9	620	1
48040URL010M65	1 x 70	28,1	700	2/0
48040URL010M66	1 x 95	29,6	800	3/0
48040URL010M67	1 x 120	31,2	910	4/0
48040URL010M68	1 x 150	32,7	1030	250 MCM
48040URL010M69	1 x 185	35	1210	350 MCM
48040URL010M70	1 x 240	37,5	1430	450 MCM
48040URL010M71	1 x 300	41,4	1730	550 MCM
48040URL010M72	1 x 400	44,6	2090	750 MCM
48040URL010M73	1 x 500	47,1	2520	1000 MCM
48040URL010M75	1 x 630	51,8	3080	1250 MCM

18/30 kV

Part no.	No. of cores x cross section n x mm ²	Outer-Ø ca. mm ± 10%	Cable weight approx. kg/km	AWG no. *)
48040XRL010M64	1 x 50	34,5	990	1
48040XRL010M65	1 x 70	34,8	1040	2/0
48040XRL010M66	1 x 95	35,8	1120	3/0
48040XRL010M67	1 x 120	36,7	1220	4/0
48040XRL010M68	1 x 150	37,6	1310	250 MCM
48040XRL010M69	1 x 185	39,1	1450	350 MCM
48040XRL010M70	1 x 240	41,8	1710	450 MCM
48040XRL010M71	1 x 300	45,3	2030	550 MCM
48040XRL010M72	1 x 400	48,9	2420	750 MCM
48040XRL010M73	1 x 500	53,4	2960	1000 MCM
48040XRL010M75	1 x 630	58,2	3560	1250 MCM

Other dimension and colors available on request.

INDUSTRIAL MEDIUM VOLTAGE CABLES

ARG7H1EX

Three-cores, overall copper wires and tape screen 12/20 kV up to 18/30 kV



Construction:

Conductor:	stranded plain aluminium conductor Cl.2, acc. to IEC 60228
Insulation:	special EPR type DIH2
Inner semi-conductive layer:	extruded compound
Outer semi-conductive layer:	strippable cold extruded compound
Screen:	red copper wires and one or two copper tape(s) applied helically.
Outer sheath:	red(RAL 3000),PE type DMZ1

Resistance:



Self-extinguishing and flame retardant acc. to:
DIN VDE 0482 part 265-2-1
EN 50265-2-1
IEC 60332-1

Technical data:

Nominal voltage:	12/20 kV up to 18/30 kV
Test voltage:	12/20 kV = 29 kV 18/30 kV = 43 kV
Temperature range:	- 25 °C / + 105 °C
Max short circuit temperature:	+ 300 °C
Min. bending radius:	13 x d
Max. tensile stress:	60 N/mm ²

Features:

according to IEC 60502-2

12/20 kV

Part no.	No. of cores x cross section n x mm ²	Outer-Ø ca. mm ± 10%	Cable weight approx. kg/km	AWG no.®)
48050URL030M63	3 x 1 x 35	52,2	5100	2
48050URL030M64	3 x 1 x 50	53,8	5580	1
48050URL030M65	3 x 1 x 70	56,2	6300	2/0
48050URL030M66	3 x 1 x 95	59,2	7260	3/0
48050URL030M67	3 x 1 x 120	62,4	8250	4/0
48050URL030M68	3 x 1 x 150	65,4	9330	250 MCM
48050URL030M69	3 x 1 x 185	70	10920	350 MCM
48050URL030M70	3 x 1 x 240	75	12930	450 MCM
48050URL030M71	3 x 1 x 300	82,8	15600	550 MCM
48050URL030M72	3 x 1 x 400	89,2	18900	750 MCM

18/30 kV

Part no.	No. of cores x cross section n x mm ²	Outer-Ø ca. mm ± 10%	Cable weight approx. kg/km	AWG no.®)
48050XRL030M64	3 x 1 x 50	69	8940	1
48050XRL030M65	3 x 1 x 70	69,6	9360	2/0
48050XRL030M66	3 x 1 x 95	71,6	10140	3/0
48050XRL030M67	3 x 1 x 120	73,4	10980	4/0
48050XRL030M68	3 x 1 x 150	75,2	11820	250 MCM
48050XRL030M69	3 x 1 x 185	78,2	13110	350 MCM
48050XRL030M70	3 x 1 x 240	83,6	15390	450 MCM
48050XRL030M71	3 x 1 x 300	90,6	18300	550 MCM
48050XRL030M72	3 x 1 x 400	97,8	21840	550 MCM

Other dimensions and colours available on request.

INDUSTRIAL MEDIUM VOLTAGE CABLES

RG7HIM1



ELETTROTEK KABEL® RG7H1M1

Construction:

Conductor:	stranded red copper conductor Cl. 2, acc to IEC 60228
Insulation:	rubber,type G7
Screen:	red copper wires and one or two copper tape(s) applied helically
Outer sheath:	red (RAL 3000),thermoplastic polyolefine,halogen-free, type M1

Technical data:

Nominal voltage:	1,8/3 kV, 3,6/6 kV, 6/10 kV 8,7/15 kV, 12/20 kV 18/30 kV, 26/45 kV
Test voltage:	1,8/3 kV = 6 kV 8,7/15 kV = 24 kV 3,6/6 kV = 11 kV 12/20 kV= 29 kV 6/10 kV = 17 kV 18/30 kV = 45 kV
Temperature range:	- 5 °C / + 105 °C
Max short circuit temperature:	+ 250 °C

Resistance:



Flame retardant acc to:
DIN VDE 0482 part 265-2-1
EN 50265-2-1
IEC 60332-3-24 CEI 20-22 III



Halogen free acc. to:
DIN VDE 0482 part 267
EN 50267-2-1
IEC 60754-1 (equivalent DIN VDE 0472 part 815)



Corrosiveness of conflagration gases acc. to:
DIN VDE 0482 part 267
EN 50267-2-2 /
IEC 60754-2 (equivalent DIN VDE 0472 part 813)

Features:

according to IEC 60502-2

Acc. to normatives DIN VDE and IEC standards.

1,8/3 kV

Part no.	No. of cores x cross section n x mm ²	Outer-Ø ca. mm ± 10%	Cable weight approx. kg/km	AWG no.®)
48060KRL010M61	1x10	14	290	8
48060KRL010M62	1x16	15	350	6
48060KRL010M63	1x25	16	450	4
48060KRL010M64	1x35	17	550	2
48060KRL010M65	1x50	18,5	670	1
48060KRL010M66	1x70	20,5	880	2/0
48060KRL010M67	1x95	22	1100	3/0
48060KRL010M68	1x120	24,5	1400	4/0
48060KRL010M69	1x150	26	1650	250 MCM
48060KRL010M70	1x185	27,5	2000	350 MCM
48060KRL010M71	1x240	30	2550	450 MCM
48060KRL010M72	1x300	32,5	3150	550 MCM
48060KRL010M73	1x400	35,5	3950	750 MCM
48060KRL010M74	1x500	40	5050	900 MCM
48060KRL010M75	1x630	44	6300	1150 MCM

3,6/6 kV

Part no.	No. of cores x cross section n x mm ²	Outer-Ø ca. mm ± 10%	Cable weight approx. kg/km	AWG no.®)
48060MRL010M61	1x10	16	330	8
48060MRL010M62	1x16	17	410	6
48060MRL010M63	1x25	18,5	510	4
48060MRL010M64	1x35	20	630	2
48060MRL010M65	1x50	21,5	750	1
48060MRL010M66	1x70	23,5	1010	2/0
48060MRL010M67	1x95	25	1250	3/0
48060MRL010M68	1x120	26,5	1500	4/0
48060MRL010M69	1x150	28	1800	250 MCM
48060MRL010M70	1x185	30	2100	350 MCM
48060MRL010M71	1x240	32,5	2650	450 MCM
48060MRL010M72	1x300	35,3	3200	550 MCM
48060MRL010M73	1x400	37,5	4000	750 MCM
48060MRL010M74	1x500	41,6	5100	900 MCM
48060MRL010M75	1x630	46	6500	1150 MCM

INDUSTRIAL MEDIUM VOLTAGE CABLES

RG7H1M1



6/10 kV

Part no.	No. of cores x cross section n x mm ²	Outer-Ø ca. mm ± 10%	Cable weight approx. kg/km	AWG no. *)
48060QRL010M61	1x10	19,5	420	8
48060QRL010M62	1x16	21	530	6
48060QRL010M63	1x25	22,2	650	4
48060QRL010M64	1x35	23	760	2
48060QRL010M65	1x50	24,5	880	1
48060QRL010M66	1x70	26,5	1100	2/0
48060QRL010M67	1x95	28	1400	3/0
48060QRL010M68	1x120	29,3	1630	4/0
48060QRL010M69	1x150	31	1900	250 MCM
48060QRL010M70	1x185	33,3	2350	350 MCM
48060QRL010M71	1x240	35,6	2900	450 MCM
48060QRL010M72	1x300	38,5	3500	550 MCM
48060QRL010M73	1x400	41	4300	750 MCM
48060QRL010M74	1x500	45	5420	900 MCM
48060QRL010M75	1x630	48	6850	1150 MCM

8,7/15 kV

Part no.	No. of cores x cross section n x mm ²	Outer-Ø ca. mm ± 10%	Cable weight approx. kg/km	AWG no. *)
48060SRL010M62	1x16	23,3	650	6
48060SRL010M63	1x25	24,5	750	4
48060SRL010M64	1x35	25,8	850	2
48060SRL010M65	1x50	27	1000	1
48060SRL010M66	1x70	28,5	1220	2/0
48060SRL010M67	1x95	30,1	1500	3/0
48060SRL010M68	1x120	32,5	1900	4/0
48060SRL010M69	1x150	33,5	2100	250 MCM
48060SRL010M70	1x185	35,5	2500	350 MCM
48060SRL010M71	1x240	38	3030	450 MCM
48060SRL010M72	1x300	41,5	3800	550 MCM
48060SRL010M73	1x400	43,3	4600	750 MCM
48060SRL010M74	1x500	47,4	5700	900 MCM
48060SRL010M75	1x630	52,6	7100	1150 MCM

12/20 kV

Part no.	No. of cores x cross section n x mm ²	Outer-Ø ca. mm ± 10%	Cable weight approx. kg/km	AWG no. *)
48060URL010M64	1x35	27,7	960	2
48060URL010M65	1x50	29	1100	1
48060URL010M66	1x70	30,5	1350	2/0
48060URL010M67	1x95	33	1650	3/0
48060URL010M68	1x120	34,8	1950	4/0
48060URL010M69	1x150	36,2	2300	250 MCM
48060URL010M70	1x185	37,6	2600	350 MCM
48060URL010M71	1x240	40,2	3200	450 MCM
48060URL010M72	1x300	43	3900	550 MCM
48060URL010M73	1x400	45,8	4800	750 MCM
48060URL010M74	1x500	50	5900	900 MCM
48060URL010M75	1x630	54	7300	1150 MCM

INDUSTRIAL MEDIUM VOLTAGE CABLES

RG7H1M1



ELETTROTEK KABEL® RG7H1M1

18/30 kV

Part no.	No. of cores x cross section n x mm ²	Outer-Ø ca. mm ± 10%	Cable weight approx. kg/km	AWG no. *)
48060XRL010M65	1x50	34,1	1400	1
48060XRL010M66	1x70	36,2	1700	2/0
48060XRL010M67	1x95	38,2	1950	3/0
48060XRL010M68	1x120	40	2230	4/0
48060XRL010M69	1x150	41	2550	250 MCM
48060XRL010M70	1x185	43	3000	350 MCM
48060XRL010M71	1x240	45	3600	450 MCM
48060XRL010M72	1x300	47	4300	550 MCM
48060XRL010M73	1x400	51,1	5200	750 MCM
48060XRL010M74	1x500	53	6300	900 MCM
48060XRL010M75	1x630	60,2	7800	1150 MCM

26/45 kV

Part no.	No. of cores x cross section n x mm ²	Outer-Ø ca. mm ± 10%	Cable weight approx. kg/km	AWG no. *)
48060ZRL010M66	1x70	41,9	2150	2/0
48060ZRL010M67	1x95	43,8	2490	3/0
48060ZRL010M68	1x120	44,8	2735	4/0
48060ZRL010M69	1x150	45,1	3020	250 MCM
48060ZRL010M70	1x185	47,1	3395	350 MCM
48060ZRL010M71	1x240	49,2	4025	450 MCM
48060ZRL010M72	1x300	52,2	4725	550 MCM
48060ZRL010M73	1x400	54,8	5635	750 MCM
48060ZRL010M74	1x500	58,6	6825	900 MCM
48060ZRL010M75	1x630	62,7	8260	1150 MCM

* For cables laying in earth a screen-cross section of 16 mm is permitted.

Other dimensions and colours available on request.

INDUSTRIAL MEDIUM VOLTAGE CABLES

RG7HI(O)M1



ELETTROTEK KABEL® RG7H10M1

Construction:

Conductor:	stranded red copper conductor Cl. 2, acc. to IEC 60228
Insulation:	rubber, type G7
Screen:	red copper tape
Inner sheath:	halogen free compound, type M1, colour natural
Outer sheath:	thermoplastic polyolefine, halogen-free, type M1

Technical data:

Nominal voltage:	1,8/3 kV, 3,6/6 kV, 6/10 kV 8,7/15 kV, 12/20 kV 18/30 kV, 26/45 kV
Test voltage:	1,8/3 kV = 6 kV 8,7/15 kV = 24 kV 3,6/6 kV = 11 kV 12/20 kV = 29 kV 6/10 kV = 17 kV 18/30 kV = 45 kV
Temperature range:	- 5 °C / + 105 °C
Max short circuit temperature:	+ 250 °C

Resistance:



Flame retardant acc to:
DIN VDE 0482 part 265-2-1
EN 50265-2-1
IEC 60332-3-24 CEI 20-22 III



Halogen free acc. to:
DIN VDE 0482 part 267
EN 50267-2-1
IEC 60754-1 (equivalent DIN VDE 0472 part 815)



Corrosiveness of conflagration gases acc. to:
DIN VDE 0482 part 267
EN 50267-2-2 /
IEC 60754-2 (equivalent DIN VDE 0472 part 813)

Features:

according to IEC 60502-2

1,8/3 kV

Part no.	No. of cores x cross section n x mm ²	Outer-Ø ca. mm ± 10%	Cable weight approx. kg/km	AWG no. *)
48060KR1030M61	3x10	27,2	904	8
48060KR1030M62	3x16	29,5	1155	6
48060KR1030M63	3x25	32,5	1575	4
48060KR1030M64	3x35	34,5	1952	2
48060KR1030M65	3x50	37,2	2332	1
48060KR1030M66	3x70	41,4	3150	2/0
48060KR1030M67	3x95	45	4024	3/0
48060KR1030M68	3x120	48,7	4918	4/0
48060KR1030M69	3x150	52,2	5791	250 MCM
48060KR1030M70	3x185	56,5	7086	350 MCM
48060KR1030M71	3x240	62	8975	450 MCM
48060KR1030M72	3x300	67,3	11069	550 MCM
48060KR1030M73	3x400	74,2	13756	750 MCM

3,6/6 kV

Part no.	No. of cores x cross section n x mm ²	Outer-Ø ca. mm ± 10%	Cable weight approx. kg/km	AWG no. *)
48060MR1030M61	3x10	31,8	1287	8
48060MR1030M62	3x16	34,4	1530	6
48060MR1030M63	3x25	37,4	1980	4
48060MR1030M64	3x35	39,7	2406	2
48060MR1030M65	3x50	42,8	2896	1
48060MR1030M66	3x70	46,3	3663	2/0
48060MR1030M67	3x95	50	4653	3/0
48060MR1030M68	3x120	54,2	5544	4/0
48060MR1030M69	3x150	57,3	6435	250 MCM
48060MR1030M70	3x185	61,5	7821	350 MCM
48060MR1030M71	3x240	66,8	9900	450 MCM
48060MR1030M72	3x300	72,9	12375	550 MCM
48060MR1030M73	3x400	78,2	15420	750 MCM

* For cables laying in earth a screen-cross section of 16 mm is permitted.

Other dimensions and colours available on request.

INDUSTRIAL MEDIUM VOLTAGE CABLES

RG7HI(O)MI



ELETTROTEK KABEL® RG7H10M1



6/10 kV

Part no.	No. of cores x cross section n x mm ²	Outer-Ø ca. mm ± 10%	Cable weight approx. kg/km	AWG no. *)
48060QR1030M61	3x10	36,9	1791	8
48060QR1030M62	3x16	39	2070	6
48060QR1030M63	3x25	42	2497	4
48060QR1030M64	3x35	44	2945	2
48060QR1030M65	3x50	47	3463	1
48060QR1030M66	3x70	51	4378	2/0
48060QR1030M67	3x95	55	5403	3/0
48060QR1030M68	3x120	57,1	6358	4/0
48060QR1030M69	3x150	62	7413	250 MCM
48060QR1030M70	3x185	66	8806	350 MCM
48060QR1030M71	3x240	72,1	10935	450 MCM
48060QR1030M72	3x300	77,8	13293	550 MCM
48060QR1030M73	3x400	85	16000	750 MCM

8,7/15 kV

Part no.	No. of cores x cross section n x mm ²	Outer-Ø ca. mm ± 10%	Cable weight approx. kg/km	AWG no. *)
48060SR1030M62	3x16	45,5	2567	6
48060SR1030M63	3x25	48	3025	4
48060SR1030M64	3x35	51,2	3512	2
48060SR1030M65	3x50	53,5	4109	1
48060SR1030M66	3x70	58	5035	2/0
48060SR1030M67	3x95	61,5	6119	3/0
48060SR1030M68	3x120	65	7094	4/0
48060SR1030M69	3x150	68,2	8199	250 MCM
48060SR1030M70	3x185	72,5	9652	350 MCM
48060SR1030M71	3x240	78,2	11860	450 MCM
48060SR1030M72	3x300	78,6	14185	550 MCM

12/20 kV

Part no.	No. of cores x cross section n x mm ²	Outer-Ø ca. mm ± 10%	Cable weight approx. kg/km	AWG no. *)
48060UR1030M64	3x35	57,6	4050	2
48060UR1030M65	3x50	60,1	4637	1
48060UR1030M66	3x70	64,5	5652	2/0
48060UR1030M67	3x95	69,5	6786	3/0
48060UR1030M68	3x120	74,8	7791	4/0
48060UR1030M69	3x150	75	8925	250 MCM
48060UR1030M70	3x185	80,3	10428	350 MCM
48060UR1030M71	3x240	84	12627	450 MCM
48060UR1030M72	3x300	91,5	15094	550 MCM

18/30 kV

Part no.	No. of cores x cross section n x mm ²	Outer-Ø ca. mm ± 10%	Cable weight approx. kg/km	AWG no. *)
48060XR1030M65	3x50	72	6420	1
48060XR1030M66	3x70	75,9	7500	2/0
48060XR1030M67	3x95	80,1	8740	3/0
48060XR1030M68	3x120	83,2	9840	4/0
48060XR1030M69	3x150	86,9	11070	250 MCM
48060XR1030M70	3x185	91	12730	350 MCM
48060XR1030M71	3x240	96,3	15060	450 MCM

* For cables laying in earth a screen-cross section of 16 mm is permitted.

Other dimensions and colours available on request.

INDUSTRIAL MEDIUM VOLTAGE CABLES

RG7HI(O)NMI



ELETTROTEK KABEL® RG7H10NM1

Construction:

Conductor:	stranded red copper conductor Cl. 2, acc. to IEC 60228
Insulation:	rubber, type G7
Screen:	red copper tape
Inner sheath:	halogen free compound, type M1, colour natural
Armour:	steel tape
Outer sheath:	red (RAL 3000), thermoplastic polyolefine, halogen-free, type M1

Technical data:

Nominal voltage:	1,8/3 kV, 3,6/6 kV, 6/10 kV 8,7/15 kV, 12/20 kV 18/30 kV, 26/45 kV
Test voltage:	1,8/3 kV = 6 kV 8,7/15 kV = 24 kV 3,6/6 kV = 11 kV 12/20 kV = 29 kV 6/10 kV = 17 kV 18/30 kV = 45 kV
Temperature range:	- 15 °C / + 90 °C
Max short circuit temperature:	+ 250 °C
Min installation temperature:	0 °C

1,8/3 kV

Part no.	No. of cores x cross section n x mm ²	Outer-Ø ca. mm ± 10%	Cable weight approx. kg/km	AWG no. (*)
48070KR1030M61	3x10	30,5	1343	8
48070KR1030M62	3x16	32,5	1642	6
48070KR1030M63	3x25	35,5	1990	4
48070KR1030M64	3x35	37,5	2388	2
48070KR1030M65	3x50	40,5	2985	1
48070KR1030M66	3x70	44,5	3861	2/0
48070KR1030M67	3x95	48	4876	3/0
48070KR1030M68	3x120	52	5871	4/0
48070KR1030M69	3x150	55,5	6915	250 MCM
48070KR1030M70	3x185	59,5	8278	350 MCM
48070KR1030M71	3x240	65	10393	450 MCM
48070KR1030M72	3x300	70,5	13154	550 MCM
48070KR1030M73	3x400	77,5	15821	750 MCM

3,6/6 kV

Part no.	No. of cores x cross section n x mm ²	Outer-Ø ca. mm ± 10%	Cable weight approx. kg/km	AWG no. (*)
48070MR1030M61	3x10	36	1525	8
48070MR1030M62	3x16	37,5	1812	6
48070MR1030M63	3x25	40,5	2267	4
48070MR1030M64	3x35	43	2723	2
48070MR1030M65	3x50	46	3544	1
48070MR1030M66	3x70	49,5	4455	2/0
48070MR1030M67	3x95	53,5	4554	3/0
48070MR1030M68	3x120	57,5	6336	4/0
48070MR1030M69	3x150	60,5	7623	250 MCM
48070MR1030M70	3x185	64,5	9009	350 MCM
48070MR1030M71	3x240	70	11187	450 MCM
48070MR1030M72	3x300	76	13662	550 MCM
48070MR1030M73	3x400	82,5	16731	750 MCM

Resistance:



Flame retardant acc. to:
DIN VDE 0482 part 265-2-1
EN 50265-2-1
IEC 60332-3-24 CEI 20-22 III



Halogen free acc. to:
acc. to DIN VDE 0482 part 267
EN 50267-2-1
IEC 60754-1 (equivalent DIN VDE 0472 part 815)



Corrosiveness of conflagration gases acc. to:
DIN VDE 0482 part 267
EN 50267-2-2
IEC 60754-2 (equivalent DIN VDE 0472 part 813)

Features:

according to IEC 60502-2

INDUSTRIAL MEDIUM VOLTAGE CABLES

RG7HI(O)NMI



ELETTROTEK KABEL® RG7H10NM1

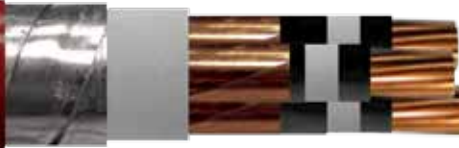

6/10 kV

Part no.	No. of cores x cross section n x mm ²	Outer-Ø ca. mm ± 10%	Cable weight approx. kg/km	AWG no.*)
48070QR1030M61	3x10	39,5	2607	8
48070QR1030M62	3x16	41,5	2965	6
48070QR1030M63	3x25	44,3	3453	4
48070QR1030M64	3x35	47,5	4040	2
48070QR1030M65	3x50	50	4617	1
48070QR1030M66	3x70	54,5	5622	2/0
48070QR1030M67	3x95	58,5	6746	3/0
48070QR1030M68	3x120	62	7831	4/0
48070QR1030M69	3x150	65,5	8965	250 MCM
48070QR1030M70	3x185	69	10408	350 MCM
48070QR1030M71	3x240	75,5	12756	450 MCM
48070QR1030M72	3x300	81,5	15258	550 MCM

12/20 kV

Part no.	No. of cores x cross section n x mm ²	Outer-Ø ca. mm ± 10%	Cable weight approx. kg/km	AWG no.*)
48070UR1030M64	3x35	58,3	5393	2
48070UR1030M65	3x50	61	6099	1
48070UR1030M66	3x70	65,5	7214	2/0
48070UR1030M67	3x95	69,5	8448	3/0
48070UR1030M68	3x120	73	9602	4/0
48070UR1030M69	3x150	76,5	10826	250 MCM
48070UR1030M70	3x185	80,5	12338	350 MCM
48070UR1030M71	3x240	86,8	14510	450 MCM
48070UR1030M72	3x300	93,5	17300	550 MCM

18/30 kV

Part no.	No. of cores x cross section n x mm ²	Outer-Ø ca. mm ± 10%	Cable weight approx. kg/km	AWG no.*)
48070XR1030M65	3x50	76	8210	1
48070XR1030M66	3x70	78	9460	2/0
48070XR1030M67	3x95	81	10810	3/0
48070XR1030M68	3x120	84,5	12080	4/0
48070XR1030M69	3x150	89	13420	250 MCM
48070XR1030M70	3x185	93	15070	350 MCM
48070XR1030M71	3x240	98	17550	450 MCM

26/45 kV

Part no.	No. of cores x cross section n x mm ²	Outer-Ø ca. mm ± 10%	Cable weight approx. kg/km	AWG no.*)
48070ZR1030M66	3x70	33,3	9157	2/0
48070ZR1030M67	3x95	35	10500	3/0
48070ZR1030M68	3x120	37	11980	4/0
48070ZR1030M69	3x150	37	12450	250 MCM
48070ZR1030M70	3x185	39	13990	350 MCM

* For cables laying in earth a screen-cross section of 16 mm is permitted.

Other dimensions and colours available on request.

INDUSTRIAL MEDIUM VOLTAGE CABLES

RG7H1O(GS)M1

Three-cores, copper tape screen, GAALSHOCK inner sheath, 12/20 kV up to 18/30 kV



ELETTROTEK KABEL® RG7H1O(GS)M1

Construction:

Conductor:	stranded red copper conductor Cl.2, acc. to IEC 60228
Insulation:	rubber type G7
Inner semi-conductive layer:	extruded compound
Outer semi-conductive layer:	strippable cold extruded compound
Screen:	red copper tape
Inner sheath:	non-hygroscopic compound
Armour:	GAAL THERM® 600 (GAALSHOCK technology)
Outer sheath:	red (RAL 3000), thermoplastic polyolefine, halogen-free, type M1

Resistance:



Self-extinguishing and Flame retardant acc to:
DIN VDE 0482 part 266-2-4
EN 50266-2-4
IEC 60332-3C



Halogen free acc. to:
EN 50267-2-1
IEC 60754-1
DIN VDE 0482 part.267-2



Corrosiveness of conflagration gases acc. to:
IEC 60754-2
DIN EN 50267-2-2,



Smoke density acc. to:
IEC 61034
EN 61034, CEI 20-38

Technical data:

Nominal voltage:	12/20 kV up to 18/30 kV
Test voltage:	29 kV 43 kV
Temperature range:	- 25 °C / + 90 °C
Max short circuit temperature:	+ 250 °C
Min. bending radius:	12 x d

Features:

according to IEC 60502-2

GAALSHOCK PROTECTION:

- 1: Excellent mechanical protection than steel
- 2: Reduced weight
- 3: Installation, storage and transport reduced costs

12/20 kV

Part no.	No. of cores x cross section n x mm ²	Outer-Ø ca. mm ± 10%	Cable weight approx. kg/km	AWG no. *)
48090UR1030M64	3 x 35	58,6	4160	2
48090UR1030M65	3 x 50	61,2	4750	1
48090UR1030M66	3 x 70	63,1	5600	2/0
48090UR1030M67	3 x 95	70,1	6880	3/0
48090UR1030M68	3 x 120	73,6	7940	4/0
48090UR1030M69	3 x 150	76,8	9050	250 MCM
48090UR1030M70	3 x 185	80,8	10520	350 MCM
48090UR1030M71	3 x 240	86,4	12760	450 MCM

18/30 kV

Part no.	No. of cores x cross section n x mm ²	Outer-Ø ca. mm ± 10%	Cable weight approx. kg/km	AWG no. *)
48090XR1030M65	3 x 50	74,2	6450	1
48090XR1030M66	3 x 70	78,3	7520	2/0
48090XR1030M67	3 x 95	82	8740	3/0
48090XR1030M68	3 x 120	85,7	9890	4/0
48090XR1030M69	3 x 150	88,9	11080	250 MCM
48090XR1030M70	3 x 185	92,6	12600	350 MCM
48090XR1030M71	3 x 240	98,4	15020	450 MCM

Other dimensions and colours available on request.

INDUSTRIAL MEDIUM VOLTAGE CABLES

RE4HIR (XLPE/CTS/PVC)



Construction:

- Conductor:** stranded red copper conductor Cl.2 acc.to IEC 60228
- Insulation:** XLPE compound
- Screen:** red copper wires and one or two copper tape(s) applied helically
- Outer sheath:** red (RAL 3000),PVC,type ST2

Resistance:



Flame retardant acc. to:
DIN VDE 0482 part 265-2-1
EN 50265-2-1
IEC 60332-1

Technical data:

- Nominal voltage:** 3,6/6 kV, 6/10 kV
8,7/15 kV, 12/20 kV
18/30 kV, 26/45 kV
- Test voltage:** 3,6/6 kV = 11 kV 12/20 kV= 29 kV
6/10 kV = 17 kV 18/30 kV = 45 kV
8,7/15 kV = 24 kV
- Temperature range:** - 15 °C / + 90 °C
- Max short circuit temperature:** + 250 °C
- Min installation temperature:** 0 °C
- Min. bending radius:** 12 x d
- Max. tensile stress:** 60 N/mm²

Features:

according to IEC 60502-2

3,6/6 kV

Part no.	No.of cores x cross section n x mm ²	Outer-Ø ca.mm ± 10%	Cable weight approx. kg/km	AWG no.*)
48100MRL010M64	1x35	18	620	2
48100MRL010M65	1x50	19,2	750	1
48100MRL010M66	1x70	20,7	970	2/0
48100MRL010M67	1x95	22,4	1240	3/0
48100MRL010M68	1x120	23,9	1470	4/0
48100MRL010M69	1x150	25,3	1780	250 MCM
48100MRL010M70	1x185	6,8	2130	350 MCM
48100MRL010M71	1x240	29,8	2730	450 MCM
48100MRL010M72	1x300	32,9	3390	550 MCM
48100MRL010M73	1x400	35,9	4260	750 MCM
48100MRL010M74	1x500	39,7	5390	900 MCM
48100MRL010M75	1x630	44,3	6880	1150 MCM

6/10 kV

Part no.	No.of cores x cross section n x mm ²	Outer-Ø ca.mm ± 10%	Cable weight approx. kg/km	AWG no.*)
48100QRL010M64	1x35	19,8	680	2
48100QRL010M65	1x50	21	810	1
48100QRL010M66	1x70	22,5	1040	2/0
48100QRL010M67	1x95	24,2	1320	3/0
48100QRL010M68	1x120	25,5	1570	4/0
48100QRL010M69	1x150	27	1850	250 MCM
48100QRL010M70	1x185	28,8	2230	350 MCM
48100QRL010M71	1x240	31,6	2830	450 MCM
48100QRL010M72	1x300	34	3460	550 MCM
48100QRL010M73	1x400	36,5	4310	750 MCM
48100QRL010M74	1x500	40	5420	900 MCM
48100QRL010M75	1x630	44,5	6910	1150 MCM

INDUSTRIAL MEDIUM VOLTAGE CABLES

RE4HIR (XLPE/CTS/PVC)



8,7/15 kV

Part no.	No. of cores x cross section n x mm ²	Outer-Ø ca. mm ± 10%	Cable weight approx. kg/km	AWG no. *)
48100SRL010M64	1x35	22	760	2
48100SRL010M65	1x50	23	900	1
48100SRL010M66	1x70	24,5	1130	2/0
48100SRL010M67	1x95	26,5	1410	3/0
48100SRL010M68	1x120	28	1690	4/0
48100SRL010M69	1x150	29,5	1970	250 MCM
48100SRL010M70	1x185	31	2360	350 MCM
48100SRL010M71	1x240	34	2950	450 MCM
48100SRL010M72	1x300	36,5	3610	550 MCM
48100SRL010M73	1x400	39	4470	750 MCM
48100SRL010M74	1x500	42,5	5590	900 MCM
48100SRL010M75	1x630	47	7100	1150 MCM

12/20 kV

Part no.	No. of cores x cross section n x mm ²	Outer-Ø ca. mm ± 10%	Cable weight approx. kg/km	AWG no. *)
48100URL010M64	1x35	24	840	2
48100URL010M65	1x50	25,2	980	1
48100URL010M66	1x70	26,5	1130	2/0
48100URL010M67	1x95	28,5	1520	3/0
48100URL010M68	1x120	30	1790	4/0
48100URL010M69	1x150	31,5	2090	250 MCM
48100URL010M70	1x185	33,2	2460	350 MCM
48100URL010M71	1x240	36	3080	450 MCM
48100URL010M72	1x300	38,5	3750	550 MCM
48100URL010M73	1x400	41,3	4620	750 MCM
48100URL010M74	1x500	44,5	5760	900 MCM
48100URL010M75	1x630	49,3	7280	1150 MCM

18/30 kV

Part no.	No. of cores x cross section n x mm ²	Outer-Ø ca. mm ± 10%	Cable weight approx. kg/km	AWG no. *)
48100XRL010M65	1x50	30,3	1230	1
48100XRL010M66	1x70	32	1500	2/0
48100XRL010M67	1x95	34	1820	3/0
48100XRL010M68	1x120	35,5	2100	4/0
48100XRL010M69	1x150	37	2390	250 MCM
48100XRL010M70	1x185	38,5	2800	350 MCM
48100XRL010M71	1x240	41,5	3450	450 MCM
48100XRL010M72	1x300	44	4120	550 MCM
48100XRL010M73	1x400	46,5	5030	750 MCM
48100XRL010M74	1x500	50	6170	900 MCM
48100XRL010M75	1x630	55	7760	1150 MCM

* For cables laying in earth a screen-cross section of 16 mm is permitted.

Other dimensions and colours available on request.

INDUSTRIAL MEDIUM VOLTAGE CABLES

RE4HI(O)R (XLPE/CTS/PVC)



ELETTROTEK KABEL® RE4H1OR

Construction:

Conductor:	stranded red copper conductor Cl.2 acc.to IEC 60228
Insulation:	XLPE compound
Screen:	red copper tape
Inner sheath:	not hygroscopic filler
Outer sheath:	red (RAL 3000),PVC,type RZ

Resistance:



Flame retardant acc. to:
DIN VDE 0482 part 265-2-1
EN 50265-2-1
IEC 60332-1

Technical data:

Nominal voltage:	3,6/6 kV, 6/10 kV 8,7/15 kV, 12/20 kV 18/30 kV
Test voltage:	3,6/6 kV = 11 kV 12/20 kV = 29 kV 6/10 kV = 17 kV 18/30 kV = 45 kV 8,7/15 kV = 24 kV
Temperature range:	0 °C / + 90 °C
Max short circuit temperature:	+ 250 °C
Min. bending radius:	14 x d

Features:

according to IEC 60502-2

3,6/6 kV

Part no.	No.of cores x cross section n x mm ²	Outer-Ø ca.mm ± 10%	Cable weight approx. kg/km	AWG no.*)
48100KR1030M64	3x35	37	2430	2
48100KR1030M65	3x50	40	2950	1
48100KR1030M66	3x70	43,2	3750	2/0
48100KR1030M67	3x95	47,3	4790	3/0
48100KR1030M68	3x120	51	5750	4/0
48100KR1030M69	3x150	54	6760	250 MCM
48100KR1030M70	3x185	57,5	8060	350 MCM
48100KR1030M71	3x240	64,3	10320	450 MCM
48100KR1030M72	3x300	71	12780	550 MCM
48100KR1030M73	3x400	77,5	15880	750 MCM

6/10 kV

Part no.	No.of cores x cross section n x mm ²	Outer-Ø ca.mm ± 10%	Cable weight approx. kg/km	AWG no.*)
48100QR1030M64	3x35	41,3	2790	2
48100QR1030M65	3x50	44	3330	1
48100QR1030M66	3x70	47,5	4180	2/0
48100QR1030M67	3x95	51,5	5250	3/0
48100QR1030M68	3x120	54,9	6220	4/0
48100QR1030M69	3x150	58,5	7320	250 MCM
48100QR1030M70	3x185	61,9	8630	350 MCM
48100QR1030M71	3x240	67,9	10840	450 MCM
48100QR1030M72	3x300	73,8	13210	550 MCM
48100QR1030M73	3x400	79,8	16290	750 MCM

INDUSTRIAL MEDIUM VOLTAGE CABLES

RE4HI(O)R (XLPE/CTS/PVC)



ELETTROTEK KABEL® RE4HIOR



8,7/15 kV

Part no.	No. of cores x cross section n x mm ²	Outer-Ø ca. mm ± 10%	Cable weight approx. kg/km	AWG no. *)
48100SR1030M64	3x35	52	3290	2
48100SR1030M65	3x50	54	3880	1
48100SR1030M66	3x70	58	4760	2/0
48100SR1030M67	3x95	62	5850	3/0
48100SR1030M68	3x120	66	6900	4/0
48100SR1030M69	3x150	70	7970	250 MCM
48100SR1030M70	3x185	74	9350	350 MCM
48100SR1030M71	3x240	78	11610	450 MCM
48100SR1030M72	3x300	85	14010	550 MCM

12/20 kV

Part no.	No. of cores x cross section n x mm ²	Outer-Ø ca. mm ± 10%	Cable weight approx. kg/km	AWG no. *)
48100UR1030M64	3x35	51	3790	2
48100UR1030M65	3x50	54	4380	1
48100UR1030M66	3x70	57,3	5300	2/0
48100UR1030M67	3x95	61,5	6470	3/0
48100UR1030M68	3x120	65	7510	4/0
48100UR1030M69	3x150	68	8610	250 MCM
48100UR1030M70	3x185	71,8	10050	350 MCM
48100UR1030M71	3x240	77,5	12300	450 MCM
48100UR1030M72	3x300	84	14920	550 MCM

18/30 kV

Part no.	No. of cores x cross section n x mm ²	Outer-Ø ca. mm ± 10%	Cable weight approx. kg/km	AWG no. *)
48100XR1030M65	3x50	65,7	5920	1
48100XR1030M66	3x70	69	6920	2/0
48100XR1030M67	3x95	73	8140	3/0
48100XR1030M68	3x120	76,5	9260	4/0
48100XR1030M69	3x150	80	10530	250 MCM
48100XR1030M70	3x185	83,5	12020	350 MCM
48100XR1030M71	3x240	89,5	14490	450 MCM

* For cables laying in earth a screen-cross section of 16 mm is permitted.

Other dimensions and colours available on request.

INDUSTRIAL MEDIUM VOLTAGE CABLES

RE4H1RFR (XLPE/CTS/PVC/AWA/PVC)



ELETTROTEK KABEL® RE4H1RFR

Construction:

Conductor:	stranded red copper conductor Cl.2 acc.to IEC 60228
Insulation:	XLPE compound
Screen:	red copper tape
Inner sheath:	PVC compound
Armour:	Aluminium wires
Outer sheath:	red (RAL 3000),PVC,type ST2

Resistance:



Flame retardant acc. to:
DIN VDE 0482 part 265-2-1
EN 50265-2-1
IEC 60332-1

Technical data:

Nominal voltage:	3,6/6 kV, 6/10 kV 8,7/15 kV, 12/20 kV 18/30 kV
Test voltage:	3,6/6 kV = 11 kV 12/20 kV= 29 kV 6/10 kV = 17 kV 18/30 kV = 45 kV 8,7/15 kV = 24 kV
Temperature range:	0 °C / + 90 °C
Max short circuit temperature:	+ 250 °C
Min. bending radius:	14 x d

Features:

according to IEC 60502-2

3,6/6 kV

Part no.	No.of cores x cross section n x mm ²	Outer-Ø ca.mm ± 10%	Cable weight approx. kg/km	AWG no.*)
48110MRL010M65	1x50	25,4	1140	1
48110MRL010M66	1x70	27,5	1380	2/0
48110MRL010M67	1x95	29	1700	3/0
48110MRL010M68	1x120	30,5	1970	4/0
48110MRL010M69	1x150	32	2280	250 MCM
48110MRL010M70	1x185	33,5	2660	350 MCM
48110MRL010M71	1x240	37	3410	450 MCM
48110MRL010M72	1x300	40	4130	550 MCM
48110MRL010M73	1x400	43,3	5060	750 MCM
48110MRL010M74	1x500	48,5	6480	900 MCM
48110MRL010M75	1x630	52,7	7900	1150 MCM

6/10 kV

Part no.	No.of cores x cross section n x mm ²	Outer-Ø ca.mm ± 10%	Cable weight approx. kg/km	AWG no.*)
48110QRL010M65	1x50	27,3	1230	1
48110QRL010M66	1x70	29	1500	2/0
48110QRL010M67	1x95	31	1820	3/0
48110QRL010M68	1x120	32,5	2100	4/0
48110QRL010M69	1x150	34,8	2490	250 MCM
48110QRL010M70	1x185	36	2880	350 MCM
48110QRL010M71	1x240	39	3540	450 MCM
48110QRL010M72	1x300	41,5	4230	550 MCM
48110QRL010M73	1x400	44,3	5150	750 MCM
48110QRL010M74	1x500	49	6510	900 MCM
48110QRL010M75	1x630	53	7950	1150 MCM

INDUSTRIAL MEDIUM VOLTAGE CABLES

RE4H1RFR (XLPE/CTS/PVC/AWA/PVC)



8,7/15 kV

Part no.	No. of cores x cross section n x mm ²	Outer-Ø ca. mm ± 10%	Cable weight approx. kg/km	AWG no. *)
48110SRL010M65	1x50	29,7	1380	1
48110SRL010M66	1x70	31,6	1650	2/0
48110SRL010M67	1x95	34	2020	3/0
48110SRL010M68	1x120	35,5	2320	4/0
48110SRL010M69	1x150	37	2640	250 MCM
48110SRL010M70	1x185	38,5	3070	350 MCM
48110SRL010M71	1x240	41,5	3730	450 MCM
48110SRL010M72	1x300	44	4420	550 MCM
48110SRL010M73	1x400	48	5530	750 MCM
48110SRL010M74	1x500	51,3	6500	900 MCM
48110SRL010M75	1x630	55,5	8180	1150 MCM

12/20 kV

Part no.	No. of cores x cross section n x mm ²	Outer-Ø ca. mm ± 10%	Cable weight approx. kg/km	AWG no. *)
48110URL010M65	1x50	31,9	1510	1
48110URL010M66	1x70	33,5	1770	2/0
48110URL010M67	1x95	36	2170	3/0
48110URL010M68	1x120	37,5	2470	4/0
48110URL010M69	1x150	39	2800	250 MCM
48110URL010M70	1x185	40,5	3210	350 MCM
48110URL010M71	1x240	43,5	3890	450 MCM
48110URL010M72	1x300	47,3	4770	550 MCM
48110URL010M73	1x400	50	5710	750 MCM
48110URL010M74	1x500	53,5	6960	900 MCM
48110URL010M75	1x630	57,5	8410	1150 MCM

18/30 kV

Part no.	No. of cores x cross section n x mm ²	Outer-Ø ca. mm ± 10%	Cable weight approx. kg/km	AWG no. *)
48110XRL010M65	1x50	38,2	1950	1
48110XRL010M66	1x70	39,8	2220	2/0
48110XRL010M67	1x95	41,7	2580	3/0
48110XRL010M68	1x120	43,2	2890	4/0
48110XRL010M69	1x150	46	3410	250 MCM
48110XRL010M70	1x185	47,9	3850	350 MCM
48110XRL010M71	1x240	50,3	4540	450 MCM
48110XRL010M72	1x300	52,9	5320	550 MCM
48110XRL010M73	1x400	56,5	6280	750 MCM
48110XRL010M74	1x500	60,1	7560	900 MCM
48110XRL010M75	1x630	-	9000	1150 MCM

* For cables laying in earth a screen-cross section of 16 mm is permitted.

Other dimensions and colours available on request.

INDUSTRIAL MEDIUM VOLTAGE CABLES

RE4HI(O)RFR (XLPE/CTS/PVC/SWA/PVC)



ELETTROTEK KABEL® RE4HIORFR



Construction:

Conductor:	stranded red copper conductor Cl.2 acc.to IEC 60228
Insulation:	XLPE compound
Screen:	red copper tape
Inner sheath:	PVC compound
Armour:	steel wires
Outer sheath:	red (RAL 3000),PVC,type ST2

Resistance:



Flame retardant acc. to:
DIN VDE 0482 part 265-2-1
EN 50265-2-1
IEC 60332-1

Technical data:

Nominal voltage:	3,6/6 kV, 6/10 kV 8,7/15 kV, 12/20 kV 18/30 kV
Test voltage:	3,6/6 kV = 11 kV 12/20 kV= 29 kV 6/10 kV = 17 kV 18/30 kV = 45 kV 8,7/15 kV = 24 kV
Temperature range:	0 °C / + 90 °C
Max short circuit temperature:	+ 250 °C
Min. bending radius:	14 x d

Features:

according to IEC 60502-2

3,6/6 kV

Part no.	No.of cores x cross section n x mm ²	Outer-Ø ca.mm ± 10%	Cable weight approx. kg/km	AWG no.*)
48110MR1030M64	3x35	44	4210	2
48110MR1030M65	3x50	48	5300	1
48110MR1030M66	3x70	52	6330	2/0
48110MR1030M67	3x95	55,5	7590	3/0
48110MR1030M68	3x120	59	8710	4/0
48110MR1030M69	3x150	62,5	9920	250 MCM
48110MR1030M70	3x185	66	11450	350 MCM
48110MR1030M71	3x240	73	13620	450 MCM
48110MR1030M72	3x300	81	17400	550 MCM

6/10 kV

Part no.	No.of cores x cross section n x mm ²	Outer-Ø ca.mm ± 10%	Cable weight approx. kg/km	AWG no.*)
48110QR1030M64	3x35	49,5	5220	2
48110QR1030M65	3x50	52,3	5940	1
48110QR1030M66	3x70	56	6980	2/0
48110QR1030M67	3x95	60	8290	3/0
48110QR1030M68	3x120	63,5	9490	4/0
48110QR1030M69	3x150	67,3	10790	250 MCM
48110QR1030M70	3x185	70,5	11900	350 MCM
48110QR1030M71	3x240	78	15300	450 MCM

INDUSTRIAL MEDIUM VOLTAGE CABLES

RE4HI(O)RFR (XLPE/CTS/PVC/SWA/PVC)



8,7/15 kV

Part no.	No. of cores x cross section n x mm ²	Outer-Ø ca. mm ± 10%	Cable weight approx. kg/km	AWG no. *)
48110SR1030M64	3x35	52	3500	2
48110SR1030M65	3x50	54	4000	1
48110SR1030M66	3x70	58	4800	2/0
48110SR1030M67	3x95	62	5900	3/0
48110SR1030M68	3x120	66	6950	4/0
48110SR1030M69	3x150	70	8000	250 MCM
48110SR1030M70	3x185	74	9500	350 MCM

12/20 kV

Part no.	No. of cores x cross section n x mm ²	Outer-Ø ca. mm ± 10%	Cable weight approx. kg/km	AWG no. *)
48110UR1030M64	3x35	54	6790	2
48110UR1030M65	3x50	56,3	7570	1
48110UR1030M66	3x70	59,6	8720	2/0
48110UR1030M67	3x95	64	9790	3/0
48110UR1030M68	3x120	68	11830	4/0
48110UR1030M69	3x150	71,5	13170	250 MCM
48110UR1030M70	3x185	74,5	14900	350 MCM

18/30 kV

Part no.	No. of cores x cross section n x mm ²	Outer-Ø ca. mm ± 10%	Cable weight approx. kg/km	AWG no. *)
48110XR1030M65	3x50	75,6	10290	1
48110XR1030M66	3x70	79,5	11600	2/0

* For cables laying in earth a screen-cross section of 16 mm is permitted.

Other dimensions and colours available on request.

INDUSTRIAL MEDIUM VOLTAGE CABLES

ARE4HIR

Single-core, overall copper wires + tape screen 12/20 kV up to 18/30 kV



Construction:

Conductor:	stranded plain aluminium conductor Cl.2, acc. to IEC 60228
Insulation:	XLPE compound
Inner semi-conductive layer:	extruded compound
Outer semi-conductive layer:	extruded compound
Screen:	red copper wires and one or two copper tape(s) applied helically
Outer sheath:	red(RAL 3000),PVC type RZ

Resistance:



Self-extinguishing and flame retardant acc. to:
DIN VDE 0482 part 265-2-1
EN 50265-2-1
IEC 60332-1

Technical data:

Nominal voltage:	12/20 kV up to 18/30 kV
Test voltage:	12/20 kV = 29 kV 18/30 kV = 43 kV
Temperature range:	0 °C / + 90 °C
Max short circuit temperature:	+ 250 °C
Min. bending radius:	13 x d
Max. tensile stress:	60 N/mm ²

Features:

according to IEC 60502-2

12/20 kV

Part no.	No. of cores x cross section n x mm ²	Outer-Ø ca.mm ± 10%	Cable weight approx. kg/km	AWG no.)*
48120URL010M64	1 x 35	26,5	640	2
48120URL010M65	1 x 50	27,7	710	1
48120URL010M66	1 x 70	29,5	820	2/0
48120URL010M67	1 x 95	31,6	940	3/0
48120URL010M68	1 x 120	33	1080	4/0
48120URL010M69	1 x 150	34,2	1180	250 MCM
48120URL010M70	1 x 185	36,3	1360	350 MCM
48120URL010M71	1 x 240	38,8	1600	450 MCM
48120URL010M72	1 x 300	42,1	1890	550 MCM
48120URL010M73	1 x 400	45,4	2270	750 MCM
48120URL010M74	1 x 500	48,6	2685	1000 MCM
48120URL010M75	1 x 630	53,4	3280	1250 MCM

18/30 kV

Part no.	No. of cores x cross section n x mm ²	Outer-Ø ca.mm ± 10%	Cable weight approx. kg/km	AWG no.)*
48120XRL010M65	1 x 50	33	960	1
48120XRL010M66	1 x 70	34,6	1070	2/0
48120XRL010M67	1 x 95	36,6	1220	3/0
48120XRL010M68	1x 120	38,1	1350	4/0
48120XRL010M69	1 x 150	39,5	1480	250 MCM
48120XRL010M70	1 x 185	41,4	1660	350 MCM
48120XRL010M71	1 x 240	44,1	1930	450 MCM
48120XRL010M72	1 x 300	47,4	2250	550 MCM
48120XRL010M73	1 x 400	50,7	2650	750 MCM
48120XRL010M74	1 x 500	53,9	3100	1000 MCM
48120XRL010M75	1 x 630	58,7	3730	1250 MCM

Other dimensions and colours available on request.

INDUSTRIAL MEDIUM VOLTAGE CABLES

ARE4HIRX

Three-cores, overall copper wires + tape screen 12/20 kV up to 18/30 kV



Construction:

Conductor:	stranded plain aluminium conductor Cl.2, acc. to IEC 60228
Insulation:	XLPE compound
Inner semi-conductive layer:	extruded compound
Outer semi-conductive layer:	extruded compound
Screen:	red copper wires and one or two copper tape(s) applied helically
Outer sheath:	red(RAL 3000),PVC type RZ

Resistance:



Self-extinguishing and flame retardant acc. to:
DIN VDE 0482 part 265-2-1
EN 50265-2-1
IEC 60332-1

Technical data:

Nominal voltage:	12/20 kV up to 18/30 kV
Test voltage:	12/20 kV = 29 kV 18/30 kV = 43 kV
Temperature range:	0 °C / + 90 °C
Max short circuit temperature:	+ 250 °C
Min. bending radius:	20 x d
Max. tensile stress:	60 N/mm ²

Features:

according to IEC 60502-2

12/20 kV

Part no.	No. of cores x cross section n x mm ²	Outer-Ø ca. mm ± 10%	Cable weight approx. kg/km	AWG no. *)
48130URL030M64	3 x 1 x 35	56,1	1930	2
48130URL030M65	3 x 1 x 50	58,8	2140	1
48130URL030M66	3 x 1 x 70	62,6	2490	2/0
48130URL030M67	3 x 1 x 95	66,3	2860	3/0
48130URL030M68	3 x 1 x 120	70,2	3260	4/0
48130URL030M69	3 x 1 x 150	72,7	3560	250 MCM
48130URL030M70	3 x 1 x 185	77,7	4100	350 MCM
48130URL030M71	3 x 1 x 240	82,6	4830	450 MCM
48130URL030M72	3 x 1 x 300	89,9	5720	550 MCM

18/30 kV

Part no.	No. of cores x cross section n x mm ²	Outer-Ø ca. mm ± 10%	Cable weight approx. kg/km	AWG no. *)
48130XRL030M65	3 x 1 x 50	70,3	2900	1
48130XRL030M66	3 x 1 x 70	73,6	3250	2/0
48130XRL030M67	3 x 1 x 95	77,8	3700	3/0
48130XRL030M68	3 x 1 x 120	81,3	4090	4/0
48130XRL030M69	3 x 1 x 150	84,3	4490	250 MCM
48130XRL030M70	3 x 1 x 185	88,3	5020	350 MCM
48130XRL030M71	3 x 1 x 240	94,1	5840	450 MCM
48130XRL030M72	3 x 1 x 300	101,3	6830	550 MCM

Other dimensions and colours available on request.

INDUSTRIAL MEDIUM VOLTAGE CABLES

ARE4H5(GS)E

Single-core, overall aluminium screen, GAALSHOCK inner sheath 12/20 kV up to 18/30 kV



Construction:

Conductor:	stranded plain aluminium conductor Cl.2, acc. to IEC 60228
Insulation:	XLPE type DIX8
Inner semi-conductive layer:	extruded compound
Outer semi-conductive layer:	extruded compound
Wrapping:	semi-conductive watertight tape
Screen:	aluminium tape
Armour:	GAALTHERM®600 (GAALSHOCK technology)
Outer sheath:	red(RAL 3000), PE type DMP

Resistance:



Self-extinguishing and flame retardant acc. to:
DIN VDE 0482 part 265-2-1
EN 50265-2-1
IEC 60332-1

Technical data:

Nominal voltage:	12/20 kV up to 18/30 kV
Test voltage:	12/20 kV = 29 kV 18/30 kV = 43 kV
Temperature range:	-25 °C / + 90 °C
Max short circuit temperature:	+ 250 °C
Min. bending radius:	13 x d

Features:

according to IEC 60502-2

GAALSHOCK PROTECTION:

- 1: Excellent mechanical protection than steel
- 2: Reduced weight
- 3: Installation, storage and transport reduced costs

INDUSTRIAL MEDIUM VOLTAGE CABLES

ARE4H5(GS)E

Single-core, overall aluminium screen, GAALSHOCK inner sheath 12/20 kV up to 18/30 kV



ELETTROTEK KABEL® ARE4H5(GS)E

12/20 kV

Part no.	No. of cores x cross section n x mm ²	Outer-Ø ca. mm ± 10%	Cable weight approx. kg/km	AWG no. *)
48140URL010M65	1 x 50	34,5	810	1
48140URL010M66	1 x 70	35,5	890	2/0
48140URL010M67	1 x 95	37	1000	3/0
48140URL010M68	1x 120	38,2	1100	4/0
48140URL010M69	1 x 150	39,5	1210	250 MCM
48140URL010M70	1 x 185	41,3	1370	350 MCM
48140URL010M71	1 x 240	44	1620	450 MCM
48140URL010M72	1 x 300	47,6	1900	550 MCM
48140URL010M73	1 x 400	51,3	2300	750 MCM
48140URL010M74	1 x 500	54,5	2710	1000 MCM
48140URL010M75	1 x 630	59,5	3310	1250 MCM

18/30 kV

Part no.	No. of cores x cross section n x mm ²	Outer-Ø ca. mm ± 10%	Cable weight approx. kg/km	AWG no. *)
48140XRL010M65	1 x 50	40,7	1110	1
48140XRL010M66	1 x 70	40,8	1150	2/0
48140XRL010M67	1 x 95	41,8	1240	3/0
48140XRL010M68	1x 120	42,9	1350	4/0
48140XRL010M69	1 x 150	43,6	1440	250 MCM
48140XRL010M70	1 x 185	45,1	1580	350 MCM
48140XRL010M71	1 x 240	47,4	1810	450 MCM
48140XRL010M72	1 x 300	50,9	2120	550 MCM
48140XRL010M73	1 x 400	54,6	2520	750 MCM
48140XRL010M74	1 x 500	58,1	2970	1000 MCM
48140XRL010M75	1 x 630	63	3590	1250 MCM

Other dimensions and colours available on request.

INDUSTRIAL MEDIUM VOLTAGE CABLES

ARE4H5(GS)EX

Three-cores, overall aluminium screen, GAALSHOCK inner sheath 12/20 kV up to 18/30 kV



ELETTROTEK KABEL® ARE4H5(GS)EX

Construction:

Conductor:	stranded plain aluminium conductor Cl.2, acc. to IEC 60228
Insulation:	XLPE type DIX8
Inner semi-conductive layer:	extruded compound
Outer semi-conductive layer:	extruded compound
Wrapping:	semi-conductive watertight tape
Screen:	aluminium tape
Armour:	GAALTHERM® 600 (GAALSHOCK technology)
Outer sheath:	red(RAL 3000), PE type DMP

Resistance:



Self-extinguishing and flame retardant acc. to:
DIN VDE 0482 part 265-2-1
EN 50265-2-1
IEC 60332-1

Technical data:

Nominal voltage:	12/20 kV up to 18/30 kV
Test voltage:	12/20 kV = 29 kV 18/30 kV = 43 kV
Temperature range:	-25 °C / + 90 °C
Max short circuit temperature:	+ 250 °C
Min. bending radius:	20 x d

Features:

according to IEC 60502-2

GAALSHOCK PROTECTION:

- 1: Excellent mechanical protection than steel
- 2: Reduced weight
- 3: Installation, storage and transport reduced costs

INDUSTRIAL MEDIUM VOLTAGE CABLES

ARE4H5(GS)EX

Three-cores, overall aluminium screen, GAALSHOCK inner sheath I2/20 kV up to I8/30 kV



12/20 kV

Part no.	No. of cores x cross section n x mm ²	Outer-Ø ca.mm ± 10%	Cable weight approx. kg/km	AWG no. *)
48150UR1030M65	3 x 1 x 50	69	2430	1
48150UR1030M66	3 x 1 x 70	71	2660	2/0
48150UR1030M67	3 x 1 x 95	74	3010	3/0
48150UR1030M68	3 x 1 x 120	76,4	3300	4/0
48150UR1030M69	3 x 1 x 150	79	3640	250 MCM
48150UR1030M70	3 x 1 x 185	82,6	4120	350 MCM
48150UR1030M71	3 x 1 x 240	88	4770	450 MCM
48150UR1030M72	3 x 1 x 300	95,2	5730	550 MCM

18/30 kV

Part no.	No. of cores x cross section n x mm ²	Outer-Ø ca.mm ± 10%	Cable weight approx. kg/km	AWG no. *)
48150XR1030M65	3 x 1 x 50	81,4	3330	1
48150XR1030M66	3 x 1 x 70	81,6	3450	2/0
48150XR1030M67	3 x 1 x 95	43,6	3730	3/0
48150XR1030M68	3 x 1 x 120	85,8	4050	4/0
48150XR1030M69	3 x 1 x 150	87,2	4310	250 MCM
48150XR1030M70	3 x 1 x 185	90,2	4740	350 MCM
48150XR1030M71	3 x 1 x 240	94,8	5440	450 MCM
48150XR1030M72	3 x 1 x 300	101,8	6360	550 MCM

Other dimensions and colours available on request.

INDUSTRIAL MEDIUM VOLTAGE CABLES

RE4HIMI (XLPE/CTS/LS0H)



ELETTROTEK KABEL® RE4H1M1



Construction:

- Conductor:** stranded red copper conductor Cl.2 acc.to IEC 60228
- Insulation:** XLPE compound
- Screen:** red copper wires and one or two copper tape(s) applied helically
- Outer sheath:** red (RAL 3000), thermoplastic polyolefine, halogen-free, type M1

Technical data:

- Nominal voltage:** 3,6/6 kV, 6/10 kV
8,7/15 kV, 12/20 kV
18/30 kV, 26/45 kV
- Test voltage:** 3,6/6 kV = 11 kV 12/20 kV = 29 kV
6/10 kV = 17 kV 18/30 kV = 45 kV
8,7/15 kV = 24 kV
- Temperature range:** -5 °C / + 90 °C
- Max short circuit temperature:** + 250 °C
- Min. bending radius:** 14 x d

Resistance:



Flame retardant acc. to:
DIN VDE 0482 part 265-2-1
EN 50265-2-1
IEC 60332-1
IEC 60332-3-24



Halogen free acc. to:
EN 50267-2-1
IEC 60754-1
DIN VDE 0482 part.267-2



Corrosiveness of conflagration gases acc. to:
IEC 60754-2
DIN EN 50267-2-2,

Features:

according to IEC 60502-2

3,6/6 kV

Part no.	No.of cores x cross section n x mm ²	Outer-Ø ca.mm ± 10%	Cable weight approx. kg/km	AWG no.*)
48160MRL010M64	1x35	18	620	2
48160MRL010M65	1x50	19,2	750	1
48160MRL010M66	1x70	20,7	970	2/0
48160MRL010M67	1x95	22,4	1240	3/0
48160MRL010M68	1x120	23,9	1470	4/0
48160MRL010M69	1x150	25,3	1780	250 MCM
48160MRL010M70	1x185	6,8	2130	350 MCM
48160MRL010M71	1x240	29,8	2730	450 MCM
48160MRL010M72	1x300	32,9	3390	550 MCM
48160MRL010M73	1x400	35,9	4260	750 MCM
48160MRL010M74	1x500	39,7	5390	900 MCM
48160MRL010M75	1x630	44,3	6880	1150 MCM

6/10 kV

Part no.	No.of cores x cross section n x mm ²	Outer-Ø ca.mm ± 10%	Cable weight approx. kg/km	AWG no.*)
48160QRL010M64	1x35	19,8	680	2
48160QRL010M65	1x50	21	810	1
48160QRL010M66	1x70	22,5	1040	2/0
48160QRL010M67	1x95	24,2	1320	3/0
48160QRL010M68	1x120	25,5	1570	4/0
48160QRL010M69	1x150	27	1850	250 MCM
48160QRL010M70	1x185	28,8	2230	350 MCM
48160QRL010M71	1x240	31,6	2830	450 MCM
48160QRL010M72	1x300	34	3460	550 MCM
48160QRL010M73	1x400	36,5	4310	750 MCM
48160QRL010M74	1x500	40	5420	900 MCM
48160QRL010M75	1x630	44,5	6910	1150 MCM

INDUSTRIAL MEDIUM VOLTAGE CABLES

RE4HIMI (XLPE/CTS/LS0H)



8,7/15 kV

Part no.	No. of cores x cross section n x mm ²	Outer-Ø ca.mm ± 10%	Cable weight approx. kg/km	AWG no.*)
48160SRL010M64	1x35	22	760	2
48160SRL010M65	1x50	23	900	1
48160SRL010M66	1x70	24,5	1130	2/0
48160SRL010M67	1x95	26,5	1410	3/0
48160SRL010M68	1x120	28	1690	4/0
48160SRL010M69	1x150	29,5	1970	250 MCM
48160SRL010M70	1x185	31	2360	350 MCM
48160SRL010M71	1x240	34	2950	450 MCM
48160SRL010M72	1x300	36,5	3610	550 MCM
48160SRL010M73	1x400	39	4470	750 MCM
48160SRL010M74	1x500	42,5	5590	900 MCM
48160SRL010M75	1x630	47	7100	1150 MCM

12/20 kV

Part no.	No. of cores x cross section n x mm ²	Outer-Ø ca.mm ± 10%	Cable weight approx. kg/km	AWG no.*)
48160URL010M64	1x35	24	840	2
48160URL010M65	1x50	25,2	980	1
48160URL010M66	1x70	26,5	1130	2/0
48160URL010M67	1x95	28,5	1520	3/0
48160URL010M68	1x120	30	1790	4/0
48160URL010M69	1x150	31,5	2090	250 MCM
48160URL010M70	1x185	33,2	2460	350 MCM
48160URL010M71	1x240	36	3080	450 MCM
48160URL010M72	1x300	38,5	3750	550 MCM
48160URL010M73	1x400	41,3	4620	750 MCM
48160URL010M74	1x500	44,5	5760	900 MCM
48160URL010M75	1x630	49,3	7280	1150 MCM

18/30 kV

Part no.	No. of cores x cross section n x mm ²	Outer-Ø ca.mm ± 10%	Cable weight approx. kg/km	AWG no.*)
48160XRL010M65	1x50	30,3	1230	1
48160XRL010M66	1x70	32	1500	2/0
48160XRL010M67	1x95	34	1820	3/0
48160XRL010M68	1x120	35,5	2100	4/0
48160XRL010M69	1x150	37	2390	250 MCM
48160XRL010M70	1x185	38,5	2800	350 MCM
48160XRL010M71	1x240	41,5	3450	450 MCM
48160XRL010M72	1x300	44	4120	550 MCM
48160XRL010M73	1x400	46,5	5030	750 MCM
48160XRL010M74	1x500	50	6170	900 MCM
48160XRL010M75	1x630	55	7760	1150 MCM

* For cables laying in earth a screen-cross section of 16 mm is permitted.

Other dimensions and colours available on request.

INDUSTRIAL MEDIUM VOLTAGE CABLES

RE4HI(O)MI (XLPE/CTS/LS0H)



ELETTROTEK KABEL® RE4HI0M1

Construction:

Conductor:	stranded red copper conductor Cl.2 acc.to IEC 60228
Insulation:	XLPE compound
Screen:	red copper tape
Inner sheath:	not hygroscopic filler
Outer sheath:	red (RAL 3000),PVC,type RZ

Technical data:

Nominal voltage:	3,6/6 kV, 6/10 kV 8,7/15 kV, 12/20 kV 18/30 kV
Test voltage:	3,6/6 kV = 11 kV 12/20 kV= 29 kV 6/10 kV = 17 kV 18/30 kV = 45 kV 8,7/15 kV = 24 kV
Temperature range:	- 5 °C / + 90 °C
Max short circuit temperature:	+ 250 °C
Min. bending radius:	14 x d

Resistance:



Flame retardant acc. to:
DIN VDE 0482 part 265-2-1
EN 50265-2-1
IEC 60332-1
IEC 60332-3-24



Halogen free acc. to:
EN 50267-2-1
IEC 60754-1,
DIN VDE 0482 part.267-2

Features:

according to IEC 60502-2

3,6/6 kV

Part no.	No.of cores x cross section n x mm ²	Outer-Ø ca.mm ± 10%	Cable weight approx. kg/km	AWG no.*)
48160MR1030M64	3x35	37	2430	2
48160MR1030M65	3x50	40	2950	1
48160MR1030M66	3x70	43,2	3750	2/0
48160MR1030M67	3x95	47,3	4790	3/0
48160MR1030M68	3x120	51	5750	4/0
48160MR1030M69	3x150	54	6760	250 MCM
48160MR1030M70	3x185	57,5	8060	350 MCM
48160MR1030M71	3x240	64,3	10320	450 MCM
48160MR1030M72	3x300	71	12780	550 MCM
48160MR1030M73	3x400	77,5	15880	750 MCM

6/10 kV

Part no.	No.of cores x cross section n x mm ²	Outer-Ø ca.mm ± 10%	Cable weight approx. kg/km	AWG no.*)
48160QR1030M64	3x35	41,3	2790	2
48160QR1030M65	3x50	44	3330	1
48160QR1030M66	3x70	47,5	4180	2/0
48160QR1030M67	3x95	51,5	5250	3/0
48160QR1030M68	3x120	54,9	6220	4/0
48160QR1030M69	3x150	58,5	7320	250 MCM
48160QR1030M70	3x185	61,9	8630	350 MCM
48160QR1030M71	3x240	67,9	10840	450 MCM
48160QR1030M72	3x300	73,8	13210	550 MCM
48160QR1030M73	3x400	79,8	16290	750 MCM

INDUSTRIAL MEDIUM VOLTAGE CABLES

RE4HI(O)MI (XLPE/CTS/LS0H)



8,7/15 kV

Part no.	No. of cores x cross section n x mm ²	Outer-Ø ca.mm ± 10%	Cable weight approx. kg/km	AWG no.)*
48160SR1030M64	3x35	52	3290	2
48160SR1030M65	3x50	54	3880	1
48160SR1030M66	3x70	58	4760	2/0
48160SR1030M67	3x95	62	5850	3/0
48160SR1030M68	3x120	66	6900	4/0
48160SR1030M69	3x150	70	7970	250 MCM
48160SR1030M70	3x185	74	9350	350 MCM
48160SR1030M71	3x240	78	11610	450 MCM
48160SR1030M72	3x300	85	14010	550 MCM

12/20 kV

Part no.	No. of cores x cross section n x mm ²	Outer-Ø ca.mm ± 10%	Cable weight approx. kg/km	AWG no.)*
48160UR1030M64	3x35	51	3790	2
48160UR1030M65	3x50	54	4380	1
48160UR1030M66	3x70	57,3	5300	2/0
48160UR1030M67	3x95	61,5	6470	3/0
48160UR1030M68	3x120	65	7510	4/0
48160UR1030M69	3x150	68	8610	250 MCM
48160UR1030M70	3x185	71,8	10050	350 MCM
48160UR1030M71	3x240	77,5	12300	450 MCM
48160UR1030M72	3x300	84	14920	550 MCM

18/30 kV

Part no.	No. of cores x cross section n x mm ²	Outer-Ø ca.mm ± 10%	Cable weight approx. kg/km	AWG no.)*
48160XR1030M65	3x50	65,7	5920	1
48160XR1030M66	3x70	69	6920	2/0
48160XR1030M67	3x95	73	8140	3/0
48160XR1030M68	3x120	76,5	9260	4/0
48160XR1030M69	3x150	80	10530	250 MCM
48160XR1030M70	3x185	83,5	12020	350 MCM
48160XR1030M71	3x240	89,5	14490	450 MCM

* For cables laying in earth a screen-cross section of 16 mm is permitted.

Other dimensions and colours available on request.

INDUSTRIAL MEDIUM VOLTAGE CABLES

NSGAFÖU 3 kV

Special rubber insulated cable



ELETTROTEK KABEL® NSGAFÖU

Construction:

- Conductor:** flexible tinned copper conductor Cl. 5, acc to EC 60228, DIN VDE 0295
- Insulation:** rubber type 3GI3, halogen free
- Outer sheath:** black(RAL 9005),rubber type,5GM3

Resistance:



Self-extinguishing and flame retardant acc. to:
DIN VDE 0482 part 265-2-1
EN 50265-2-1
IEC 60332-1
EN 60332-1-2

Technical data:

- Nominal voltage:** 1,8 / 3,6 kV
- Test voltage:** 6 kV
- Temperature range**
- Fixed laying:* - 40 °C / +90 °C
- Flexible application:* - 25 °C / +90 °C

Features:

UV resistant

Applications:

This insulated wire is designed for application busses and railborn veichles. if used in distribution or switching appliances the wire is considered to be short circuit proof . the cable is halogen-free, flame retardant and resistant against moist oils and grease.

Part no.	No.of cores x cross section n x mm ²	Outer-Ø ca.mm ± 10%	Copper weight kg/km	Cable weight approx. kg/km	AWG no.®)
48170K7L010M15	1x1,5	6,3	14,4	51	16
48170K7L010M25	1x2,5	6,7	24	63	14
48170K7L010M40	1x4	7,4	6,4	82	12
48170K7L010M60	1x6	7,9	7	103	10
48170K7L010M61	1x10	9,5	8,4	159	8
48170K7L010M62	1x16	10,5	9,2	219	6
48170K7L010M63	1x25	12,8	11,5	335	4
48170K7L010M64	1x35	14,1	12,8	435	2
48170K7L010M65	1x50	15,9	14,3	582	1
48170K7L010M66	1x70	17,8	672	757	2/0
48170K7L010M67	1x95	20,1	912	1040	3/0
48170K7L010M68	1x120	22	1152	1289	4/0
48170K7L010M69	1x150	24	1440	1581	250 MCM
48170K7L010M70	1x185	26,3	1776	1895	350 MCM
48170K7L010M71	1x240	29,6	2304	2452	450 MCM
48170K7L010M72	1x300	32,2	2880	2998	550 MCM

Other dimensions and colours available on request.

INDUSTRIAL MEDIUM VOLTAGE CABLES

NSHXAFÖ 3 kV

Special rubber insulated cable



CE

ELETTROTEK KABEL® NSHXAFÖ

Construction:

- Conductor:** flexible red copper conductor Cl. 5, acc to EC 60228, DIN VDE 0295
- Insulation:** rubber type 3GI3, halogen free
- Outer sheath:** black(RAL 9005),halogen free type HM3

Technical data:

- Nominal voltage:** 1,8 / 3,6 kV
- Test voltage:** 6 kV
- Temperature range**
- Fixed laying:* - 40 °C / +70 °C
- Flexible application:* - 25 °C / +70 °C

Resistance:



Self-extinguishing and flame retardant acc. to:
DIN VDE 0482 part 265-2-1
EN 50265-2-1
IEC 60332-1
EN 60332-1-2



Halogen free acc. to:
EN 50267-2-1
IEC 60754-1
DIN VDE 0482 part.267-2



Oil resistant:
IEC 60811-2-1
DIN VDE 0473 part 811-2-1

Applications:

This insulated wire is designed for application busses and railborn veichles.
if used in distribution or switching appliances the wire is considered to be short circuit proof .
the cable is halogen-free, flame retardant and resistant against moist oils and grease.

Part no.	No.of cores x cross section n x mm ²	Outer-Ø ca.mm ± 10%	Copper weight kg/km	Cable weight approx. kg/km	AWG no.*)
48180K7L010M15	1x1.5	7	14,4	60	16
48180K7L010M25	1x2.5	7,5	24	70	14
48180K7L010M40	1x4	9	38	85	12
48180K7L010M60	1x6	9,5	58	110	10
48180K7L010M61	1x10	11	96	160	8
48180K7L010M62	1x16	13	154	240	6
48180K7L010M63	1x25	15	240	365	4
48180K7L010M64	1x35	16,5	336	494	2
48180K7L010M65	1x50	18	480	656	1
48180K7L010M66	1x70	20,5	672	880	2/0
48180K7L010M67	1x95	24	912	1090	3/0
48180K7L010M68	1x120	25,1	1152	1340	4/0
48180K7L010M69	1x150	28	1440	1640	250 MCM
48180K7L010M70	1x185	31	1776	2160	350 MCM
48180K7L010M71	1x240	34,5	2304	2570	450 MCM
48180K7L010M72	1x300	38	2880	3470	550 MCM
48180K7L010M73	1x400	40,1	3840	4180	750 MCM
48180K7L010M74	1x500	42,1	4800	5860	950 MCM

Other dimensions and colours available on request.

INDUSTRIAL MEDIUM VOLTAGE CABLES

N2XSY 6/10 kV, 12/20 kV, 18/30 kV PVC- jacket



ELETTROTEK KABEL® N2XSY



Construction:

Conductor:	stranded red copper conductor Cl.2 acc.to IEC 60228
Insulation:	XLPE compound
Screen:	red copper wires and one or two copper tape(s) applied helically
Outer sheath:	red (RAL 3000), PVC type DMV6

Resistance:







Flame retardant acc. to:
DIN VDE 0482 part 265-2-1
EN 50265-2-1
IEC 60332-1-2

On request:
IEC 60332-3/22 or 60332-3/24,
DIN VDE 0482-332-3 part 266-4-2 or 266-5-2
EN 60322-3

Technical data:

Nominal voltage:	6/10 kV, 12/20 kV, 18/30 kV
Test voltage:	6/10 kV = 17 kV 12/20 kV = 29 kV 18/30 kV = 45 kV
Temperature range:	- 5 °C / + 70 °C

Features:

-  re: circular solid conductor
-  rm: circular stranded conductor
-  sm: sector-shaped stranded conductor
-  se: sector-shaped solid conductor

Applications:

Suitable for installation mostly for power supply stations, in indoors and in cable ducts, outdoors, underground, and in water as well as for installation on cable trays for industries, switch-boards and power stations. Due to the good laying characteristics, this can also be laid easily in difficult line guideways. See DIN VDE 0298 part 1 .

6/10 kV

Part no.	No.of cores x cross section n x mm ²	Outer-Ø ca.mm ± 10%	Copper weight kg/km	Cable weight approx. kg/km	AWG no.*)
48190QRL010M64	1x35 rm/16	25,5	518	905	2
48190QRL010M65	1x50 rm/16	26,5	662	1080	1
48190QRL010M66	1x70 rm/16	28,5	860	1310	2/0
48190QRL010M67	1x95 rm/16	29,5	1098	1580	3/0
48190QRL010M68	1x120 rm/16	31,5	1340	1860	4/0
48191QRL010M69	1x150 rm/16*	32,5	1622	2040	250 MCM
48190QRL010M69	1x150 rm/25	32,5	1725	2210	250 MCM
48191QRL011M70	1x185 rm/16*	36,5	1958	2450	350 MCM
48190QRL010M70	1x185 rm/25	36,5	2059	2580	350 MCM
48191QRL011M71	1x240 rm/16*	38,5	2486	3000	450 MCM
48190QRL010M71	1x240 rm/25	38,5	2587	3130	450 MCM
48190QRL010M72	1x300 rm/25	38,5	3163	3780	550 MCM
48190QRL010M73	1x400 rm/35	42,5	4234	4670	750 MCM
48190QRL010M74	1x500 rm/35	45,5	5194	5750	1000 MCM

INDUSTRIAL MEDIUM VOLTAGE CABLES

N2XSY 6/10 kV, 12/20 kV, 18/30 kV PVC- jacket



12/20 kV

Part no.	No. of cores x cross section n x mm ²	Outer-Ø ca. mm ± 10%	Copper weight kg/km	Cable weight approx. kg/km	AWG no. *)
48190URL010M64	1x35 rm/16	29,5	518	1110	2
48190URL010M65	1x50 rm/16	30,5	662	1250	1
48190URL010M66	1x70 rm/16	32,5	860	1510	2/0
48190URL010M67	1x95 rm/16	33,5	1098	1780	3/0
48190URL010M68	1x120 rm/16	35,5	1340	2070	4/0
48191URL011M69	1x150 rm/16*	36,5	1622	2310	250 MCM
48190URL010M69	1x150 rm/25	36,5	1725	2420	250 MCM
48191URL011M70	1x185 rm/16*	38,5	1958	2650	350 MCM
48190URL010M70	1x185 rm/25	38,5	2059	2810	350 MCM
48191URL011M71	1x240 rm/16*	41,5	2486	3260	450 MCM
48190URL010M71	1x240 rm/25	41,5	2587	3360	450 MCM
48190URL010M72	1x300 rm/25	43,5	3163	4020	550 MCM
48190URL010M73	1x400 rm/35	46,5	4234	4930	750 MCM
48190URL010M74	1x500 rm/35	49,5	5194	6050	1000 MCM

18/30 kV

Part no.	No. of cores x cross section n x mm ²	Outer-Ø ca. mm ± 10%	Copper weight kg/km	Cable weight approx. kg/km	AWG no. *)
48190XRL010M65	1x50 rm/16	35,5	662	1480	1
48190XRL010M66	1x70 rm/16	37,5	854	1730	2/0
48190XRL010M67	1x95 rm/16	38,5	1094	2060	3/0
48190XRL010M68	1x120 rm/16	40,5	1334	2330	4/0
48190XRL010M69	1x150 rm/25	41,5	1723	2720	300 MCM
48190XRL010M70	1x185 rm/25	43,5	2059	3100	350 MCM
48190XRL010M71	1x240 rm/25	45,5	2587	3730	500 MCM
48190XRL010M72	1x300 rm/25	48,5	3163	4000	600 MCM
48190XRL010M73	1x400 rm/35	51,5	4234	5330	750 MCM
48190XRL010M74	1x500 rm/35	54,5	5194	6480	1000 MCM

* For cables laying in earth a screen-cross section of 16 mm is permitted.

Other dimensions and colours available on request.

INDUSTRIAL MEDIUM VOLTAGE CABLES

N2XS2Y 6/10 kV, 12/20 kV, 18/30 kV PE- jacket



ELETTROTEK KABEL® N2XS2Y







Construction:

- Conductor:** stranded red copper conductor Cl.2 acc.to IEC 60228
- Insulation:** XLPE,type DIX 8
- Screen:** red copper wires and one or two copper tape(s) applied helically
- Outer sheath:** black (RAL 9005),PE type DMP2

Features:

Water resistant

-  re: circular solid conductor
-  rm: circular stranded conductor
-  sm: sector-shaped stranded conductor
-  se: sector-shaped solid conductor

Technical data:

- Nominal voltage:** 6/10 kV, 12/20 kV, 18/30 kV
- Test voltage:** 6/10 kV = 17 kV
12/20 kV= 29 kV
18/30 kV = 45 kV
- Temperature range:** - 20 °C / + 70 °C

Applications:

Suitable for installation mostly for power supply stations, in indoors and in cable ducts, outdoors, underground, and in water as well as for installation on cable trays for industries, switch-boards and power stations. Due to the good laying characteristics, this can also be laid easily in difficult line guideways. See DIN VDE 0298 part 1 .

6/10 kV

Part no.	No.of cores x cross section n x mm ²	Outer-Ø ca.mm ± 10%	Copper weight kg/km	Cable weight approx. kg/km	AWG no.)*
48200Q7L010M64	1x35 rm/16	25,5	518	910	2
48200Q7L010M65	1x50 rm/16	26,5	662	990	1
48200Q7L010M66	1x70 rm/16	28,5	860	1205	2/0
48200Q7L010M67	1x95 rm/16	29,5	1098	1520	3/0
48200Q7L010M68	1x120 rm/16	31,5	1340	1760	4/0
48201Q7L010M69	1x150 rm/16*	32,5	1622	2020	250 MCM
48200Q7L010M69	1x150 rm/25	32,5	1725	2130	250 MCM
48201Q7L011M70	1x185 rm/16*	34,5	1958	2360	350 MCM
48200Q7L010M70	1x185 rm/25	34,5	2059	2470	350 MCM
48201Q7L011M71	1x240 rm/16*	36,5	2486	2960	450 MCM
48200Q7L010M71	1x240 rm/25	36,5	2587	3020	450 MCM
48200Q7L010M72	1x300 rm/25	38,5	3163	3630	550 MCM
48200Q7L010M73	1x400 rm/35	42,5	4234	4560	750 MCM
48200Q7L010M74	1x500 rm/35	45,5	5194	5580	1000 MCM

INDUSTRIAL MEDIUM VOLTAGE CABLES

N2XS2Y 6/10 kV, 12/20 kV, 18/30 kV PE- jacket



ELETTROTEK KABEL® N2XS2Y

12/20 kV

Part no.	No.of cores x cross section n x mm ²	Outer-Ø ca.mm ± 10%	Copper weight kg/km	Cable weight approx. kg/km	AWG no.)*
48200U7L010M64	1x35 rm/16	29,5	518	960	2
48200U7L010M65	1x50 rm/16	30,5	662	1160	1
48200U7L010M66	1x70 rm/16	32,5	854	1410	2/0
48200U7L010M67	1x95 rm/16	33,5	1094	1670	3/0
48200U7L010M68	1x120 rm/16	35,5	1334	1860	4/0
48201U7L011M69	1x150 rm/16*	36,5	1622	2220	250 MCM
48200U7L010M69	1x150 rm/25	36,5	1723	2310	250 MCM
48201U7L011M70	1x185 rm/16*	38,5	1958	2620	350 MCM
48200U7L010M70	1x185 rm/25	38,5	2059	2670	350 MCM
48201U7L011M71	1x240 rm/16*	41,5	2486	3160	450 MCM
48200U7L010M71	1x240 rm/25	41,5	2587	3270	450 MCM
48200U7L010M72	1x300 rm/25	43,5	3163	3880	550 MCM
48200U7L010M73	1x400 rm/35	46,5	4234	4820	750 MCM
48200U7L010M74	1x500 rm/35	49,5	5194	5860	1000 MCM

18/30 kV

Part no.	No.of cores x cross section n x mm ²	Outer-Ø ca.mm ± 10%	Copper weight kg/km	Cable weight approx. kg/km	AWG no.)*
48200X7L010M65	1x50 rm/16	35,5	662	1410	1
48200X7L010M66	1x70 rm/16	37,5	1410	1660	2/0
48200X7L010M67	1x95 rm/16	38,5	1660	1970	3/0
48200X7L010M68	1x120 rm/16	40,5	1970	2220	4/0
48200X7L010M69	1x150 rm/25	41,5	2220	2650	300 MCM
48200X7L010M70	1x185 rm/25	43,5	2650	2980	350 MCM
48200X7L010M71	1x240 rm/25	45,5	2980	3570	500 MCM
48200X7L010M72	1x300 rm/25	48,5	3570	4220	600 MCM
48200X7L010M73	1x400 rm/35	51,5	4220	5170	750 MCM
48200X7L010M74	1x500 rm/35	54,5	5170	6260	1000 MCM

* For cables laying in earth a screen-cross section of 16 mm is permitted.

Other dimensions and colours available on request.

INDUSTRIAL MEDIUM VOLTAGE CABLES

N2XS(F)2Y 6/10 kV, 12/20 kV, 18/30 kV PE- jacket and WATER TIGHT







ELETTROTEK KABEL® N2XS F2Y

Construction:

Conductor:	stranded red copper conductor Cl.2 acc.to IEC 60228
Insulation:	XLPE,type DIX 8
Screen:	red copper wires and one or two copper tape(s) applied helically
Wrapping:	semi-conductive watertight tape
Outer sheath:	black (RAL 9005),PE type DMP2

Features:

Water resistant

	re: circular solid conductor
	rm: circular stranded conductor
	sm: sector-shaped stranded conductor
	se: sector-shaped solid conductor

Technical data:

Nominal voltage:	6/10 kV, 12/20 kV, 18/30 kV
Test voltage:	6/10 kV = 17 kV 12/20 kV= 29 kV 18/30 kV = 45 kV
Temperature range:	- 20 °C / + 70 °C

Applications:

Suitable for indoor installation and in cable ducts, outdoors, underground and in water as well as for installations in cable trays for industries, switchboards and power station.

6/10 kV

Part no.	No.of cores x cross section n x mm ²	Outer-Ø ca.mm ± 10%	Copper weight kg/km	Cable weight approx. kg/km	AWG no.)*
48210Q7L010M64	1x35 rm/16	26	518	850	2
48210Q7L010M65	1x50 rm/16	28	662	1150	1
48210Q7L010M66	1x70 rm/16	30	854	1460	2/0
48210Q7L010M67	1x95 rm/16	31	1094	1700	3/0
48210Q7L010M68	1x120 rm/16	32	1334	2030	4/0
48210Q7L010M69	1x150 rm/25	34	1723	2350	250 MCM
48210Q7L010M70	1x185 rm/25	36	2059	2700	350 MCM
48210Q7L010M71	1x240 rm/25	38	2587	3300	450 MCM
48210Q7L010M72	1x300 rm/25	40	3163	3900	550 MCM
48210Q7L010M73	1x400 rm/35	44	4234	4850	750 MCM
48210Q7L010M74	1x500 rm/35	47	5194	6000	1000 MCM

INDUSTRIAL MEDIUM VOLTAGE CABLES

N2XS(F)2Y 6/10 kV, 12/20 kV, 18/30 kV PE- jacket and WATER TIGHT



ELETTROTEK KABEL® N2XS(F)2Y

12/20 kV

Part no.	No. of cores x cross section n x mm ²	Outer-Ø ca. mm ± 10%	Copper weight kg/km	Cable weight approx. kg/km	AWG no. *)
48210U7L010M64	1x35 rm/16	31	518	1210	2
48210U7L010M65	1x50 rm/16	33	662	1400	1
48210U7L010M66	1x70 rm/16	34	854	1550	2/0
48210U7L010M67	1x95 rm/16	36	1094	1800	3/0
48210U7L010M68	1x120 rm/16	37	1334	2150	4/0
48210U7L010M69	1x150 rm/25	39	1723	2400	250 MCM
48210U7L010M70	1x185 rm/25	41	2059	2850	350 MCM
48210U7L010M71	1x240 rm/25	43	2587	3250	450 MCM
48210U7L010M72	1x300 rm/25	45	3163	3850	550 MCM
48210U7L010M73	1x400 rm/35	48	4234	4900	750 MCM
48210U7L010M74	1x500 rm/35	52	5194	6100	1000 MCM

18/30 kV

Part no.	No. of cores x cross section n x mm ²	Outer-Ø ca. mm ± 10%	Copper weight kg/km	Cable weight approx. kg/km	AWG no. *)
48210X7L010M64	1x35 rm/16	31	518	-	2
48210X7L010M65	1x50 rm/16	33	662	1650	1
48210X7L010M66	1x70 rm/16	34	854	1900	2/0
48210X7L010M67	1x95 rm/16	36	1094	2150	3/0
48210X7L010M68	1x120 rm/16	37	1334	2450	4/0
48210X7L010M69	1x150 rm/25	39	1723	2750	250 MCM
48210X7L010M70	1x185 rm/25	41	2059	3150	350 MCM
48210X7L010M71	1x240 rm/25	43	2587	3800	450 MCM
48210X7L010M72	1x300 rm/25	45	3163	4400	550 MCM
48210X7L010M73	1x400 rm/35	48	4234	5450	750 MCM
48210X7L010M74	1x500 rm/35	52	5194	6550	1000 MCM

* For cables laying in earth a screen-cross section of 16 mm is permitted.

Other dimensions and colours available on request.

INDUSTRIAL MEDIUM VOLTAGE CABLES

N2XSEY 6/10, 12/20 and 18/30 kV

XLPE-Insulated,PVC Jacket



ELETTROTEK KABEL® N2XSEY



Construction:

- Conductor:** stranded red copper conductor Cl.2 acc.to IEC 60228
- Insulation:** XLPE compound
- Screen:** red copper wires and one or two copper tape(s) applied helically
- Outer sheath:** red (RAL 3000),PVC,type YM5

Resistance:







Flame retardant acc. to:
DIN VDE 0482 part 265-2-1
EN 50265-2-1
IEC 60332-1

Technical data:

- Nominal voltage:** 6/10 kV, 12/20 kV, 18/30 kV
- Test voltage:** 6/10 kV = 17 kV
12/20 kV= 29 kV
18/30 kV = 45 kV
- Temperature range:** - 5 °C / + 70 °C

Features:

on request: EN 60332-3-24

-  re: circular solid conductor
-  rm: circular stranded conductor
-  sm: sector-shaped stranded conductor
-  se: sector-shaped solid conductor

Applications:

High operational reliability is assured by the combination of both conducting layers in combination with the insulation. Suitable for installation in indoors and in cable ducts,outdoor as well as for laying on racks for industry and switching systems and power plants.

6/10 kV

Part no.	No.of cores x cross section n x mm ²	Outer-Ø ca.mm ± 10%	Cable weight approx. kg/km	AWG no.®)
48220QR1030M61	3x10 rm/10	36,9	1898	8
48220QR1030M62	3x16 rm 16	39,1	2244	6
48220QR1030M63	3x25 rm/16	43,0	2850	4
48220QR1030M64	3x35 rm/16	48,0	3300	2
48220QR1030M65	3x50 rm/16	50,0	3750	1
48220QR1030M66	3x70 rm/16	54,0	4650	2/0
48220QR1030M67	3x95 rm/16	58,0	5700	3/0
48220QR1030M68	3x120 rm/16	61,0	6700	4/0
48220QR1030M69	3x150 rm/25	65,0	7900	250 MCM
48220QR1030M70	3x185 rm/25	68,0	9200	350 MCM
48220QR1030M71	3x240 rm/25	74,0	11450	450 MCM
48220QR1030M72	3x300 rm/25	79,0	14450	550 MCM
48220QR1030M73	3x400 rm/35	83,1	17151	750 MCM
48220QR1030M74	3x500 rm/35	91,5	20962	1000 MCM

INDUSTRIAL MEDIUM VOLTAGE CABLES

N2XSEY 6/10, 12/20 and 18/30 kV

XLPE-Insulated,PVC Jacket



ELETTROTEK KABEL® N2XSEY



12/20 kV

Part no.	No.of cores x cross section n x mm ²	Outer-Ø ca.mm ± 10%	Cable weight approx. kg/km	AWG no.®)
48220UR1030M63	3x25 rm/16	51,5	3483	4
48220UR1030M64	3x35 rm/16	54,5	4100	2
48220UR1030M65	3x50 rm/16	57,4	4801	1
48220UR1030M66	3x70 rm/16	61,1	5719	2/0
48220UR1030M67	3x95 rm/16	64,9	6675	3/0
48220UR1030M68	3x120 rm/16	68,0	7880	4/0
48220UR1030M69	3x150 rm/25	71,1	8975	250 MCM
48220UR1030M70	3x185 rm/25	75,8	10444	350 MCM
48220UR1030M71	3x240 rm/25	80,5	12573	450 MCM
48220UR1030M72	3x300 rm/25	87,4	14967	550 MCM

18/30 kV

Part no.	No.of cores x cross section n x mm ²	Outer-Ø ca.mm ± 10%	Cable weight approx. kg/km	AWG no.®)
48220XR1030M64	3x35 rm/16	65,8	5472	2
48220XR1030M65	3x50 rm/16	69,0	6414	1
48220XR1030M66	3x70 rm/16	72,7	7423	2/0
48220XR1030M67	3x95 rm/16	76,5	8601	3/0
48220XR1030M68	3x120 rm/16	79,9	9737	4/0
48220XR1030M69	3x150 rm/25	82,7	10953	250 MCM
48220XR1030M70	3x185 rm/25	87,4	12549	350 MCM
48220XR1030M71	3x240 rm/25	91,4	14721	450 MCM
48220XR1030M72	3x300 rm/25	98,1	17131	550 MCM

* For cables laying in earth a screen-cross section of 16 mm is permitted.

Other dimensions and colours available on request.

INDUSTRIAL MEDIUM VOLTAGE CABLES

NF2XSE(GS)Y or NFA2XSE(GS)Y

Three-cores, copper wires screen, GAALSHOCK inner sheath, 3,6/6 kV up to 18/30 kV



Construction:

Conductor:	copper or aluminium strands conductor Cl. 2, acc. to IEC 60228 on request water blocked conductor
Insulation:	XLPE compound or HEPR compound
Inner semi-conductive layer:	extruded compound
Outer semi-conductive layer:	extruded compound
Screen:	copper wires, on request water blocking screen
Armour:	GAALTHERM® 600 (GAALSHOCK technology)
Outer sheath:	red(RAL 3000),PVC compound

Resistance:



Self-extinguishing and flame retardant acc. to:
DIN VDE 0482 part 265-2-1
EN 50265-2-1
IEC 60332-1
EN 60332-3-24

Technical data:

Nominal voltage:	3,6/6 kV (7200)V up to 18/30 kV (3600)V
Test voltage:	3,6/6 (7200)V = 6 kV 6/10 (12000)V = 11 kV 8,7/15(1750)V = 24 kV 12/20 (24000)V = 29 kV 18/30 (36000)V = 43 kV
Temperature range:	- 25 °C / + 90 °C
Max short circuit temperature:	+ 250 °C
Min. bending radius	
<i>Fixed laying:</i>	20 x d
<i>Flexible application:</i>	15 x d

Features:

- according to IEC 60502-2
 - UV, weather, chemical and water resistance
 - on request acc. to SPLN, ICEA/NEMA
 - on request PVC-FR compound (flame retardant), LSOH or PE compound, other colors on request
- GAALSHOCK PROTECTION:**
- 1: Excellent mechanical protection than steel
 - 2: Reduced weight
 - 3: Installation, storage and transport reduced costs

3,6/6 (7,2) kV

COPPER CONDUCTOR, XLPE INSULATION, COPPER WIRES SCREEN, GAALSHOCK INNER SHEATH, PVC OUTER SHEATH

Part no.	No.of cores x cross section n x mm ²	Outer-Ø ca.mm ± 10%	Cable weight approx. kg/km	AWG no.®)
48230MR1030M65	3 x 1 x 50	59	2803	1
48230MR1030M66	3 x 1 x 70	63	3460	2/0
48230MR1030M67	3 x 1 x 95	67	4240	3/0
48230MR1030M68	3 x 1 x 120	70	5039	4/0
48230MR1030M69	3 x 1 x 150	73	6080	250 MCM
48230MR1030M70	3 x 1 x 185	77	7198	350 MCM
48230MR1030M71	3 x 1 x 240	83	8879	450 MCM
48230MR1030M72	3 x 1 x 300	89	10750	550 MCM
48230MR1030M73	3 x 1 x 400	97	13289	750 MCM

INDUSTRIAL MEDIUM VOLTAGE CABLES

NF2XSE(GS)Y or NFA2XSE(GS)Y

Three-cores, copper wires screen, GAALSHOCK inner sheath, 3,6/6 kV up to 18/30 kV



6/10 (12) kV

COPPER CONDUCTOR, XLPE INSULATION, COPPER WIRES SCREEN, GAALSHOCK INNER SHEATH, PVC OUTER SHEATH

Part no.	No. of cores x cross section n x mm ²	Outer-Ø ca. mm ± 10%	Cable weight approx. kg/km	AWG no. *)
48230QR1030M65	3 x 1 x 50	64	3003	1
48230QR1030M66	3 x 1 x 70	67	3650	2/0
48230QR1030M67	3 x 1 x 95	71	4470	3/0
48230QR1030M68	3 x 1 x 120	74	5254	4/0
48230QR1030M69	3 x 1 x 150	78	6335	250 MCM
48230QR1030M70	3 x 1 x 185	81	7438	350 MCM
48230QR1030M71	3 x 1 x 240	87	9138	450 MCM
48230QR1030M72	3 x 1 x 300	92	10975	550 MCM
48230QR1030M73	3 x 1 x 400	99	13414	750 MCM

8,7/15 (17,5) kV

COPPER CONDUCTOR, XLPE INSULATION, COPPER WIRES SCREEN, GAALSHOCK INNER SHEATH, PVC OUTER SHEATH

Part no.	No. of cores x cross section n x mm ²	Outer-Ø ca. mm ± 10%	Cable weight approx. kg/km	AWG no. *)
48230SR1030M65	3 x 1 x 50	69	3253	1
48230SR1030M66	3 x 1 x 70	72	3945	2/0
48230SR1030M67	3 x 1 x 95	76	4755	3/0
48230SR1030M68	3 x 1 x 120	80	5584	4/0
48230SR1030M69	3 x 1 x 150	82	6645	250 MCM
48230SR1030M70	3 x 1 x 185	87	7808	350 MCM
48230SR1030M71	3 x 1 x 240	92	9529	450 MCM
48230SR1030M72	3 x 1 x 300	97	11395	550 MCM
48230SR1030M73	3 x 1 x 400	104	13869	750 MCM

12/20 (24) kV

COPPER CONDUCTOR, XLPE INSULATION, COPPER WIRES SCREEN, GAALSHOCK INNER SHEATH, PVC OUTER SHEATH

Part no.	No. of cores x cross section n x mm ²	Outer-Ø ca. mm ± 10%	Cable weight approx. kg/km	AWG no. *)
48230UR1030M65	3 x 1 x 50	73	3533	1
48230UR1030M66	3 x 1 x 70	77	4240	2/0
48230UR1030M67	3 x 1 x 95	81	5065	3/0
48230UR1030M68	3 x 1 x 120	84	5914	4/0
48230UR1030M69	3 x 1 x 150	87	6985	250 MCM
48230UR1030M70	3 x 1 x 185	92	8163	350 MCM
48230UR1030M71	3 x 1 x 240	97	9914	450 MCM
48230UR1030M72	3 x 1 x 300	101	11765	550 MCM
48230UR1030M73	3 x 1 x 400	108	14549	750 MCM

18/30 (36) kV

COPPER CONDUCTOR, XLPE INSULATION, COPPER WIRES SCREEN, GAALSHOCK INNER SHEATH, PVC OUTER SHEATH

Part no.	No. of cores x cross section n x mm ²	Outer-Ø ca. mm ± 10%	Cable weight approx. kg/km	AWG no. *)
48230XR1030M65	3 x 1 x 50	85	4298	1
48230XR1030M66	3 x 1 x 70	89	5070	2/0
48230XR1030M67	3 x 1 x 95	93	5915	3/0
48230XR1030M68	3 x 1 x 120	96	6804	4/0
48230XR1030M69	3 x 1 x 150	99	7660	250 MCM
48230XR1030M70	3 x 1 x 185	103	8893	350 MCM
48230XR1030M71	3 x 1 x 240	108	10654	450 MCM
48230XR1030M72	3 x 1 x 300	113	12615	550 MCM
48230XR1030M73	3 x 1 x 400	120	15179	750 MCM

Other dimensions and colours available on request.

INDUSTRIAL MEDIUM VOLTAGE CABLES

NF2XSE(GS)Y or NFA2XSE(GS)Y

Three-cores, copper wires screen, GAALSHOCK inner sheath, 3,6/6 kV up to 18/30 kV



3,6/6 (7,2) kV

ALLUMINIUM CONDUCTOR, XLPE INSULATION, COPPER WIRES SCREEN, GAALSHOCK INNER SHEATH, PVC OUTER SHEATH

Part no.	No. of cores x cross section n x mm ²	Outer-Ø ca. mm ± 10%	Cable weight approx. kg/km	AWG no. *)
48231MR1030M65	3 x 1 x 50	59	1945	1
48231MR1030M66	3 x 1 x 70	63	2235	2/0
48231MR1030M67	3 x 1 x 95	67	2545	3/0
48231MR1030M68	3 x 1 x 120	70	2880	4/0
48231MR1030M69	3 x 1 x 150	73	3410	250 MCM
48231MR1030M70	3 x 1 x 185	77	3865	350 MCM
48231MR1030M71	3 x 1 x 240	83	4475	450 MCM
48231MR1030M72	3 x 1 x 300	89	5295	550 MCM
48231MR1030M73	3 x 1 x 400	97	6350	750 MCM

6/10 (12) kV

ALLUMINIUM CONDUCTOR, XLPE INSULATION, COPPER WIRES SCREEN, GAALSHOCK INNER SHEATH, PVC OUTER SHEATH

Part no.	No. of cores x cross section n x mm ²	Outer-Ø ca. mm ± 10%	Cable weight approx. kg/km	AWG no. *)
48231QR1030M65	3 x 1 x 50	64	2145	1
48231QR1030M66	3 x 1 x 70	67	2425	2/0
48231QR1030M67	3 x 1 x 95	71	2775	3/0
48231QR1030M68	3 x 1 x 120	74	3095	4/0
48231QR1030M69	3 x 1 x 150	78	3665	250 MCM
48231QR1030M70	3 x 1 x 185	81	4105	350 MCM
48231QR1030M71	3 x 1 x 240	87	4735	450 MCM
48231QR1030M72	3 x 1 x 300	92	5520	550 MCM
48231QR1030M73	3 x 1 x 400	99	6475	750 MCM

8,7/15 (17,5) kV

ALLUMINIUM CONDUCTOR, XLPE INSULATION, COPPER WIRES SCREEN, GAALSHOCK INNER SHEATH, PVC OUTER SHEATH

Part no.	No. of cores x cross section n x mm ²	Outer-Ø ca. mm ± 10%	Cable weight approx. kg/km	AWG no. *)
48231SR1030M65	3 x 1 x 50	69	2395	1
48231SR1030M66	3 x 1 x 70	72	2720	2/0
48231SR1030M67	3 x 1 x 95	76	3060	3/0
48231SR1030M68	3 x 1 x 120	80	3425	4/0
48231SR1030M69	3 x 1 x 150	82	3975	250 MCM
48231SR1030M70	3 x 1 x 185	87	4475	350 MCM
48231SR1030M71	3 x 1 x 240	92	5125	450 MCM
48231SR1030M72	3 x 1 x 300	97	5940	550 MCM
48231SR1030M73	3 x 1 x 400	104	6930	750 MCM

INDUSTRIAL MEDIUM VOLTAGE CABLES

NF2XSE(GS)Y or NFA2XSE(GS)Y

Three-cores, copper wires screen, GAALSHOCK inner sheath, 3,6/6 kV up to 18/30 kV



12/20 (24) kV

ALLUMINIUM CONDUCTOR, XLPE INSULATION, COPPER WIRES SCREEN, GAALSHOCK INNER SHEATH, PVC OUTER SHEATH

Part no.	No.of cores x cross section n x mm ²	Outer-Ø ca.mm ± 10%	Cable weight approx. kg/km	AWG no.*)
48231UR1030M65	3 x 1 x 50	73	2675	1
48231UR1030M66	3 x 1 x 70	77	3015	2/0
48231UR1030M67	3 x 1 x 95	81	3370	3/0
48231UR1030M68	3 x 1 x 120	84	3755	4/0
48231UR1030M69	3 x 1 x 150	87	4315	250 MCM
48231UR1030M70	3 x 1 x 185	92	4830	350 MCM
48231UR1030M71	3 x 1 x 240	97	5510	450 MCM
48231UR1030M72	3 x 1 x 300	101	6310	550 MCM
48231UR1030M73	3 x 1 x 400	108	7610	750 MCM

18/30 (36) kV

ALLUMINIUM CONDUCTOR, XLPE INSULATION, COPPER WIRES SCREEN, GAALSHOCK INNER SHEATH, PVC OUTER SHEATH

Part no.	No.of cores x cross section n x mm ²	Outer-Ø ca.mm ± 10%	Cable weight approx. kg/km	AWG no.*)
48231XR1030M65	3 x 1 x 50	85	3440	1
48231XR1030M66	3 x 1 x 70	89	3845	2/0
48231XR1030M67	3 x 1 x 95	93	4220	3/0
48231XR1030M68	3 x 1 x 120	96	4645	4/0
48231XR1030M69	3 x 1 x 150	99	4990	250 MCM
48231XR1030M70	3 x 1 x 185	103	5560	350 MCM
48231XR1030M71	3 x 1 x 240	108	6250	450 MCM
48231XR1030M72	3 x 1 x 300	113	7160	550 MCM
48231XR1030M73	3 x 1 x 400	120	8240	750 MCM

Other dimensions and colours available on request.

INDUSTRIAL MEDIUM VOLTAGE CABLES

NA2XSY 6/10 kV, 12/20 kV, 18/30 kV

PVC power cable, Alu conductor



ELETTROTEK KABEL® NA2XSY



Construction:

Conductor:	stranded plain aluminium conductor Cl.2 acc.to IEC 60228
Insulation:	XLPE type DIX8
Screen:	red copper wires and one or two copper tape(s) applied helically
Outer sheath:	red (RAL 3000), PVC type DMV6

Resistance:







Flame retardant acc. to:

DIN VDE 0482 VDE 0482-332-1-2 part 265-2-1
EN 50265-2-1
IEC 60332-1

Technical data:

Nominal voltage:	6/10 kV, 12/20 kV, 18/30 kV
Test voltage:	6/10 kV = 17 kV 12/20 kV = 29 kV 18/30 kV = 45 kV
Temperature range:	- 5 °C / + 70 °C

Features:

-  re: circular solid conductor
-  rm: circular stranded conductor
-  sm: sector-shaped stranded conductor
-  se: sector-shaped solid conductor

Applications:

Suitable for installation mostly for power supply stations, in indoors and in cable ducts, outdoors, underground, and in water as well as for installation on cable trays for industries, switch-boards and power stations. Due to the good laying characteristics, this can also be laid easily in difficult line guideways. See DIN VDE 0298 part 1.

6/10 kV

Part no.	No.of cores x cross section n x mm ²	Outer-Ø ca.mm ± 10%	Alu weight kg/km	Cable weight approx. kg/km	AWG no.*)
48240QRL010M64	1x35 rm/16	25,5	-	-	2
48240QRL010M65	1x50 rm/16	26,5	145	780	1
48240QRL010M66	1x70 rm/16	28,5	203	870	2/0
48240QRL010M67	1x95 rm/16	29,5	276	990	3/0
48240QRL010M68	1x120 rm/16	31,5	348	1100	4/0
48241QRL010M69	1x150 rm/16*	32,5	435	1250	250 MCM
48240QRL010M69	1x150 rm/25	32,5	435	1300	250 MCM
48241QRL011M70	1x185 rm/16*	34,5	537	1400	350 MCM
48240QRL010M70	1x185 rm/25	34,5	537	1450	350 MCM
48241QRL011M71	1x240 rm/16*	36,5	696	1600	450 MCM
48240QRL010M71	1x240 rm/25	36,5	696	1650	450 MCM
48240QRL010M72	1x300 rm/25	38,5	870	1950	550 MCM
48240QRL010M73	1x400 rm/35	42,5	1160	2350	750 MCM
48240QRL010M74	1x500 rm/35	45,5	1450	2700	1000 MCM

Other dimensions and colours available on request.

INDUSTRIAL MEDIUM VOLTAGE CABLES

NA2XSY 6/10 kV, 12/20 kV, 18/30 kV

PVC power cable, Alu conductor



ELETTROTEK KABEL® NA2XSY



12/20 kV

Part no.	No. of cores x cross section n x mm ²	Outer-Ø ca. mm ± 10%	Alu weight kg/km	Cable weight approx. kg/km	AWG no. *)
48240URL010M64	1x35 rm/16	29,5	-	-	2
48240URL010M65	1x50 rm/16	30,5	145	970	1
48240URL010M66	1x70 rm/16	32,5	203	1110	2/0
48240URL010M67	1x95 rm/16	33,5	276	1220	3/0
48240URL010M68	1x120 rm/16	35,5	348	1310	4/0
48241URL010M69	1x150 rm/16*	36,5	435	1460	250 MCM
48240URL010M69	1x150 rm/25	36,5	435	1520	250 MCM
48241URL011M70	1x185 rm/16*	38,5	537	1660	350 MCM
48240URL010M70	1x185 rm/25	38,5	537	1720	350 MCM
48241URL011M71	1x240 rm/16*	41,5	696	1910	450 MCM
48240URL010M71	1x240 rm/25	41,5	696	1860	450 MCM
48240URL010M72	1x300 rm/25	43,5	870	2220	550 MCM
48240URL010M73	1x400 rm/35	46,5	1160	2620	750 MCM
48240URL010M74	1x500 rm/35	49,5	1450	3030	1000 MCM

18/30 kV

Part no.	No. of cores x cross section n x mm ²	Outer-Ø ca. mm ± 10%	Alu weight kg/km	Cable weight approx. kg/km	AWG no. *)
48240XRL010M65	1x50 rm/16	35,5	145	1260	1
48240XRL010M66	1x70 rm/16	37,5	203	1360	2/0
48240XRL010M67	1x95 rm/16	38,5	276	1510	3/0
48240XRL010M68	1x120 rm/16	40,5	348	1610	4/0
48240XRL010M69	1x150 rm/25	41,5	435	1810	250 MCM
48240XRL010M70	1x185 rm/25	43,5	537	2020	350 MCM
48240XRL010M71	1x240 rm/25	45,5	696	2260	450 MCM
48240XRL010M72	1x300 rm/25	48,5	870	2560	550 MCM
48240XRL010M73	1x400 rm/35	51,5	1160	2960	750 MCM
48240XRL010M74	1x500 rm/35	54,5	1450	3460	1000 MCM

* For cables laying in earth a screen-cross section of 16 mm is permitted.

Other dimensions and colours available on request.

INDUSTRIAL MEDIUM VOLTAGE CABLES

NA2XS(F)2Y 6/10 kV, 12/20 kV, 18/30 kV

Pe-jacket and WATER TIGHT,Alu conductor







ELETTROTEK KABEL® NA2XS F2Y

Construction:

Conductor:	stranded plain aluminium conductor Cl.2 acc.to IEC 60228
Insulation:	XLPE,type DIX 8
Screen:	red copper wires and one or two copper tape(s) applied helically
Wrapping:	semi-conductive watertight tape
Outer sheath:	black (RAL 9005),PE type DMP 2

Features:

Water resistant

	re: circular solid conductor
	rm: circular stranded conductor
	sm: sector-shaped stranded conductor
	se: sector-shaped solid conductor

Technical data:

Nominal voltage:	6/10 kV, 12/20 kV, 18/30 kV
Test voltage:	6/10 kV = 17 kV 12/20 kV= 29 kV 18/30 kV = 45 kV
Temperature range:	- 20 °C / + 70 °C

Applications:

Suitable for indoor installation and in cable ducts, outdoors, underground and in water as well as for installations in cable trays for industries, switchboards and power station.

6/10 kV

Part no.	No.of cores x cross section n x mm ²	Outer-Ø ca.mm ± 10%	Alu weight kg/km	Cable weight approx. kg/km	AWG no.*)
48250Q7L010M65	1x50 rm/16	25	145	850	1
48250Q7L010M66	1x70 rm/16	27	203	950	2/0
48250Q7L010M67	1x95 rm/16	28	276	1100	3/0
48250Q7L010M68	1x120 rm/16	30	348	1200	4/0
48250Q7L010M69	1x150 rm/25	31	435	1400	250 MCM
48250Q7L010M70	1x185 rm/25	33	537	1550	350 MCM
48250Q7L010M71	1x240 rm/25	35	696	1750	450 MCM
48250Q7L010M72	1x300 rm/25	37	870	2050	550 MCM
48250Q7L010M73	1x400 rm/35	40	1160	2450	750 MCM
48250Q7L010M74	1x500 rm/35	44	1450	2850	1000MCM

INDUSTRIAL MEDIUM VOLTAGE CABLES

NA2XS(F)2Y 6/10 kV, 12/20 kV, 18/30 kV

Pe-jacket and WATER TIGHT, Alu conductor



12/20 kV

Part no.	No. of cores x cross section n x mm ²	Outer-Ø ca. mm ± 10%	Alu weight kg/km	Cable weight approx. kg/km	AWG no. *)
48250U7L010M65	1x50 rm/16	29	145	950	1
48250U7L010M66	1x70 rm/16	31	203	1050	2/0
48250U7L010M67	1x95 rm/16	32	276	1300	3/0
48250U7L010M68	1x120 rm/16	34	348	1450	4/0
48250U7L010M69	1x150 rm/25	36	435	1650	250 MCM
48250U7L010M70	1x185 rm/25	37	537	1800	350 MCM
48250U7L010M71	1x240 rm/25	40	696	2050	450 MCM
48250U7L010M72	1x300 rm/25	42	870	2300	550 MCM
48250U7L010M73	1x400 rm/35	45	1160	2800	750 MCM
48250U7L010M74	1x500 rm/35	48	1450	3200	1000 MCM
48250U7L010M75	1x630 rm/35	52	1827	3268	1150 MCM

18/30 kV

Part no.	No. of cores x cross section n x mm ²	Outer-Ø ca. mm ± 10%	Alu weight kg/km	Cable weight approx. kg/km	AWG no. *)
48250X7L010M65	1x50 rm/16	35	145	1164	1
48250X7L010M66	1x70 rm/16	38	203	1289	2/0
48250X7L010M67	1x95 rm/16	40	276	1427	3/0
48250X7L010M68	1x120 rm/16	41	348	1550	4/0
48250X7L010M69	1x150 rm/25	42	435	1770	250 MCM
48250X7L010M70	1x185 rm/25	45	537	1939	350 MCM
48250X7L010M71	1x240 rm/25	50	696	2189	450 MCM
48250X7L010M72	1x300 rm/25	51	870	2458	550 MCM
48250X7L010M73	1x400 rm/35	52	1160	2918	750 MCM
48250X7L010M74	1x500 rm/35	53	1450	3343	1000 MCM
48250X7L010M75	1x630 rm/35	57	1827	3450	1150 MCM

* For cables laying in earth a screen-cross section of 16 mm is permitted.

Other dimensions and colours available on request.

INDUSTRIAL MEDIUM VOLTAGE CABLES

NA2XS(FL)2Y 6/10 kV, 12/20 kV, 18/30 kV

Pe-jacket and WATER TIGHT,Alu conductor



ELETTROTEK KABEL® NA2XSFL2Y







Construction:

Conductor:	stranded plain aluminium conductor Cl.2 acc.to IEC 60228
Insulation:	XLPE,type DIX 8
Screen:	red copper wires and one or two copper tape(s) applied helically
Wrapping:	semi-conductive watertight tape
Radial protection:	aluminium tape
Outer sheath:	black (RAL 9005),PE type DMP 2

Features:

Water resistant

	re: circular solid conductor
	rm: circular stranded conductor
	sm: sector-shaped stranded conductor
	se: sector-shaped solid conductor

Technical data:

Nominal voltage:	6/10 kV, 12/20 kV, 18/30 kV
Test voltage:	6/10 kV = 17 kV 12/20 kV= 29 kV 18/30 kV = 45 kV
Temperature range:	- 20 °C / + 70 °C

Applications:

Heavy duty rubber cable are suited as a connecting cable for very high mechanical stress in underground mining and tools for use in industries and outdoor use. They are also.

6/10 kV

Part no.	No.of cores x cross section n x mm ²	Outer-Ø ca.mm ± 10%	Alu weight kg/km	Cable weight approx. kg/km	AWG no.*)
48260Q7L010M64	1 X 35 rm / 16	25	94	683	2
48260Q7L010M65	1 X 50 rm / 16	28	127	745	1
48260Q7L010M66	1 X 70 rm / 16	30	183	846	2/0
48260Q7L010M67	1 X 95 rm / 16	31	254	961	3/0
48260Q7L010M68	1 X 120 rm / 16	32	321	1064	4/0
48260Q7L010M69	1 x 150 rm / 25	35	435	1156	250 MCM
48260Q7L010M70	1 x 185 rm / 25	37	495	1409	350 MCM
48260Q7L010M71	1 x 240 rm / 25	39	649	1850	450 MCM
48260Q7L010M72	1 x 300 rm / 25	40	812	2466	550 MCM
48260Q7L010M73	1 x 400 rm / 35	44	1043	2466	750 MCM
48260Q7L010M74	1 x 500 rm / 35	47	1374	2599	1000 MCM

INDUSTRIAL MEDIUM VOLTAGE CABLES

NA2XS(FL)2Y 6/10 kV, 12/20 kV, 18/30 kV

Pe-jacket and WATER TIGHT, Alu conductor



ELETTROTEK KABEL® NA2XSFL2Y

12/20 kV

Part no.	No. of cores x cross section n x mm ²	Outer-Ø ca. mm ± 10%	Alu weight kg/km	Cable weight approx. kg/km	AWG no. *)
48260U7L010M65	1 X 50 rm / 16	30	127	927	1
48260U7L010M66	1 X 70 rm / 16	32	183	1039	2/0
48260U7L010M67	1 X 95 rm / 16	35	254	1165	3/0
48260U7L010M68	1 X 120 rm / 16	37	321	1194	4/0
48260U7L010M69	1 x 150 rm / 25	39	435	1487	250 MCM
48260U7L010M70	1 x 185 rm / 25	40	495	1644	350 MCM
48260U7L010M71	1 x 240 rm / 25	42	649	1876	450 MCM
48260U7L010M72	1 x 300 rm / 25	45	812	2114	550 MCM
48260U7L010M73	1 x 400 rm / 35	47	1043	2537	750 MCM
48260U7L010M74	1 x 500 rm / 35	50	1374	2919	1000 MCM

18/30 kV

Part no.	No. of cores x cross section n x mm ²	Outer-Ø ca. mm ± 10%	Alu weight kg/km	Cable weight approx. kg/km	AWG no. *)
48260X7L010M65	1 X 50 rm / 16	36	127	1064	1
48260X7L010M66	1 X 70 rm / 16	38	183	1289	2/0
48260X7L010M67	1 X 95 rm / 16	40	254	1427	3/0
48260X7L010M68	1 X 120 rm / 16	41	321	1550	4/0
48260X7L010M69	1 x 150 rm / 25	42	435	1770	250 MCM
48260X7L010M70	1 x 185 rm / 25	45	495	1939	350 MCM
48260X7L010M71	1 x 240 rm / 25	47	649	2189	450 MCM
48260X7L010M72	1 x 300 rm / 25	49	812	2458	550 MCM
48260X7L010M73	1 x 400 rm / 35	51	1043	2918	750 MCM
48260X7L010M74	1 x 500 rm / 35	55	1374	3343	1000 MCM

* For cables laying in earth a screen-cross section of 16 mm is permitted.

Other dimensions and colours available on request.

INSTRUMENTATION CABLES



INSTRUMENTATION CABLES

FR2XOHR 300/500 and 450/750 V



ELETTROTEK KABEL® FR2XOHR

ELETTROTEK KABEL® FR2XOHR

Construction:

Conductor:	flexible red or tinned copper conductor Cl.5, acc. to IEC 60228
Insulation:	PVC, type R2
Colour cores:	pair(s): blue-black, with black progressively numbere triad(s): blue-brown-black, with black progressively numbered
Stranding:	conductors twisted in pairs-triads, pairs-triads twisted in concentric layers
Screen:	electrostatic screen of plastic and aluminium tape + tinned drain-wire
Outer sheath:	black (RAL 9005), blue (RAL 5015) or grey (RAL 7001), PVC, type RZ

Resistance:



Flame retardant acc. to:
DIN VDE 0482 part 265-2-1
EN 50265-2-1
IEC 60332-1
EN 60332-3-24 CEI 20-22 III



Low smoke emission acc to:
CEI 20-37, IEC 60754

Technical data:

Nominal voltage:	up to 0,75 mm ² : Uo/U 300/500 V from 1 mm ² : Uo/U 450/750 V
Test voltage:	up to 0,75 mm ² : 2 kV from 1 mm ² : 2,5 kV
Temperature range:	-10 °C / + 70 °C
Min. bending radius:	10 x d

INSTRUMENTATION CABLES

FR2XOHR 300/500 and 450/750 V

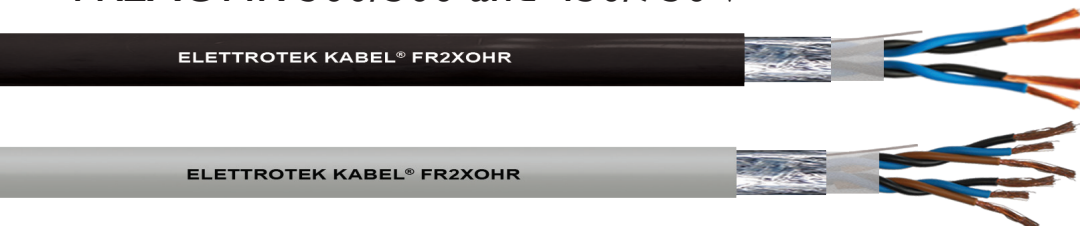

Part no.	No. of pairs/triples x cross section n x mm ²	Outer-Ø ca.mm ± 10%	Copper weight kg/km	Cable weight approx. kg/km	Inductance L (µH/m)
47010D.X022M05	2x2x0,50	7	24	85	0,90
47010D.X032M05	3x2x0,50	7,5	33,6	72	0,90
47010D.X042M05	4x2x0,50	8	43,2	91	0,90
47010D.X052M05	5x2x0,50	9	52,8	113	0,90
47010D.X062M05	6x2x0,50	10	62,4	128	0,90
47010D.X082M05	8x2x0,50	11	81,6	166	0,90
47010D.X102M05	10x2x0,50	12,5	100,8	204	0,90
47010D.X122M05	12x2x0,50	13	120	235	0,90
47010D.X162M05	16x2x0,50	14,5	158,4	302	0,90
47010D.X202M05	20x2x0,50	16,5	196,8	378	0,90
47010D.X242M05	24x2x0,50	17,5	234,8	438	0,90
47010D.X012M07	1x2x0,75	6,8	16	50	0,85
47010D.X022M07	2x2x0,75	8	33,6	76	0,85
47010D.X032M07	3x2x0,75	8,5	48	98	0,85
47010D.X042M07	4x2x0,75	9,6	62,4	125	0,85
47010D.X052M07	5x2x0,75	10,5	76,8	154	0,85
47010D.X062M07	6x2x0,75	11,5	91,2	175	0,85
47010D.X082M07	8x2x0,75	12,5	120	226	0,85
47010D.X102M07	10x2x0,75	14,5	148,8	280	0,85
47010D.X122M07	12x2x0,75	15	177,6	331	0,85
47010D.X162M07	16x2x0,75	17	235,2	425	0,85
47010D.X202M07	20x2x0,75	19	292,8	514	0,85
47010D.X242M07	24x2x0,75	20,5	350,4	607	0,85
47010E.X022M10	2x2x1	9	43,2	91	0,85
47010E.X032M10	3x2x1	9,5	62,4	121	0,85
47010E.X042M10	4x2x1	10,5	81,6	156	0,85
47010E.X052M10	5x2x1	11,5	100,8	186	0,85
47010E.X062M10	6x2x1	13	120	221	0,85
47010E.X082M10	8x2x1	14	158,4	281	0,85
47010E.X102M10	10x2x1	15,5	196,8	345	0,85
47010E.X122M10	12x2x1	16,5	235,2	405	0,85
47010E.X162M10	16x2x1	18,5	312	511	0,85
47010E.X202M10	20x2x1	20,5	388,8	618	0,85
47010E.X242M10	24x2x1	22,5	464,8	733	0,85
47010E.X022M15	2x2x1,50	11	62,4	134	0,85
47010E.X032M15	3x2x1,50	11,5	91,2	173	0,85
47010E.X042M15	4x2x1,50	12,5	120	221	0,85
47010E.X052M15	5x2x1,50	14	148,8	270	0,85
47010E.X062M15	6x2x1,50	15,5	177,6	321	0,85
47010E.X082M15	8x2x1,50	16,5	235,2	406	0,85
47010E.X102M15	10x2x1,50	19	292,8	497	0,85
47010E.X122M15	12x2x1,50	20	350,4	575	0,85
47010E.X162M15	16x2x1,50	22,5	464,8	744	0,85
47010E.X202M15	20x2x1,50	25	580,8	905	0,85
47010E.X242M15	24x2x1,50	27	696	1067	0,85
47010D.X013M07	1x3x0,75	7	23	70	0,85
47010D.X023M07	2x3x0,75	12,2	46	160	0,85
47010D.X043M07	4x3x0,75	14,2	87	250	0,85
47010E7X063M15	6x3x1,5	22	292	510	0,85

* The point inside the part number refers to the different colors in which outer sheath can be produced. Each color has different letter.

Other dimensions and colours available on request.

INSTRUMENTATION CABLES

FR2XHOHR 300/500 and 450/750 V



Construction:

Conductor:	flexible red or tinned copper conductor Cl.5, acc. to IEC 60228
Insulation:	PVC, type R2
Colour cores:	pair(s): blue-black, with black progressively numbere triad(s): blue-brown-black, with black progressively numbered
Stranding:	conductors twisted in pairs-triads, pairs-triads twisted in concentric layers
Screen	
<i>Individual:</i>	electrostatic screen of plastic and aluminium tape + tinned drain-wire
<i>Overall:</i>	electrostatic screen of plastic and aluminium tape + tinned drain-wire
Outer sheath:	black (RAL 9005), blue (RAL 5015) or grey (RAL 7001), PVC, type RZ

Resistance:



Flame retardant acc. to:
DIN VDE 0482 part 265-2-1
EN 50265-2-1
IEC 60332-1
EN 60332-3-24 CEI 20-22 III



Low smoke emission acc to:
CEI 20-37, IEC 60754

Technical data:

Nominal voltage:	up to 0,75 mm ² : U ₀ /U 300/500 V from 1 mm ² : U ₀ /U 450/750 V
Test voltage:	up to 0,75 mm ² : 2 kV from 1 mm ² : 2,5 kV
Temperature range:	-10 °C / + 70 °C
Min. bending radius:	10 x d

INSTRUMENTATION CABLES

FR2XHOHR 300/500 and 450/750 V

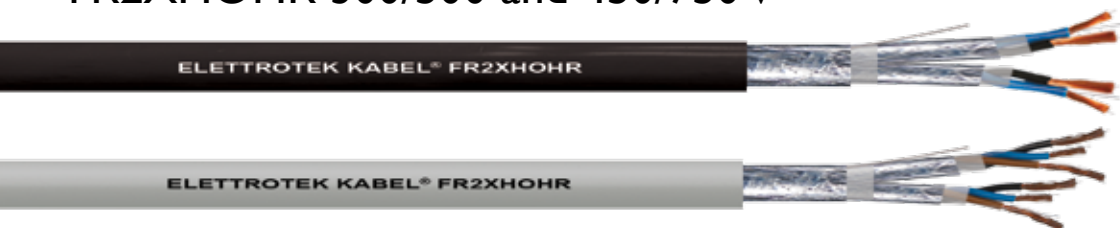

Part no.	No. of pairs/triples x cross section n x mm ²	Outer-Ø ca.mm ± 10%	Copper weight kg/km	Cable weight approx. kg/km	Inductance L (µH/m)
47020D.X022M05	2x2x0,50	7,5	33,6	68	0,90
47020D.X032M05	3x2x0,50	8	48	90	0,90
47020D.X042M05	4x2x0,50	8,5	62,4	110	0,90
47020D.X052M05	5x2x0,50	9,5	76,8	136	0,90
47020D.X062M05	6x2x0,50	10,5	91,2	162	0,90
47020D.X082M05	8x2x0,50	11,5	120	202	0,90
47020D.X102M05	10x2x0,50	13	148,8	253	0,90
47020D.X122M05	12x2x0,50	14	177,6	295	0,90
47020D.X162M05	16x2x0,50	15,5	235,2	383	0,90
47020D.X202M05	20x2x0,50	17,5	292,8	470	0,90
47020D.X242M05	24x2x0,50	18,5	350	547	0,90
47020D.X022M07	2x2x0,75	8,5	43,2	88	0,85
47020D.X032M07	3x2x0,75	9,3	62,4	117	0,85
47020D.X042M07	4x2x0,75	10	81,6	143	0,85
47020D.X052M07	5x2x0,75	11,5	96	178	0,85
47020D.X062M07	6x2x0,75	12,5	120	211	0,85
47020D.X082M07	8x2x0,75	13,5	158,4	272	0,85
47020D.X102M07	10x2x0,75	15,5	196,8	337	0,85
47020D.X122M07	12x2x0,75	16	235,2	387	0,85
47020D.X162M07	16x2x0,75	18,5	312	507	0,85
47020D.X202M07	20x2x0,75	20	388,8	614	0,85
47020D.X242M07	24x2x0,75	22	465,6	719	0,85
47020E.X022M10	2x2x1	9,5	52,8	106	0,85
47020E.X032M10	3x2x1	10	76,8	136	0,85
47020E.X042M10	4x2x1	11	100,8	176	0,85
47020E.X052M10	5x2x1	12,5	124,8	217	0,85
47020E.X062M10	6x2x1	13,7	148,8	256	0,85
47020E.X082M10	8x2x1	14,5	196,8	319	0,85
47020E.X102M10	10x2x1	16,9	244,8	404	0,85
47020E.X122M10	12x2x1	17,6	292,8	463	0,85
47020E.X162M10	16x2x1	20	388,8	599	0,85
47020E.X202M10	20x2x1	22	448,8	727	0,85
47020E.X242M10	24x2x1	24	580,8	844	0,85
47020E.X022M15	2x2x1,50	11,5	72	146	0,85
47020E.X032M15	3x2x1,50	12,5	105,6	196	0,85
47020E.X042M15	4x2x1,50	13,5	139,2	247	0,85
47020E.X052M15	5x2x1,50	15	172,8	303	0,85
47020E.X062M15	6x2x1,50	16,5	206,4	360	0,85
47020E.X082M15	8x2x1,50	18	273,6	455	0,85
47020E.X102M15	10x2x1,50	20,5	340,8	555	0,85
47020E.X122M15	12x2x1,50	21	408	639	0,85
47020E.X162M15	16x2x1,50	24	542,4	821	0,85
47020E.X202M15	20x2x1,50	26,5	676,8	1010	0,85
47020E.X242M15	24x2x1,50	29	811,2	1193	0,85
47020D.X023M07	2x3x0,75	12,4	48	170	0,85
47020D.X043M07	4x3x0,75	14,4	94	270	0,85
47020D.X063M07	6x3x0,75	16,9	140	370	0,85
47020D.X083M07	8x3x0,75	19,8	185	500	0,85

* The point inside the part number refers to the different colors in which outer sheath can be produced. Each color has different letter.

Other dimensions and colours available on request.

INSTRUMENTATION CABLES

FR2XOHRAR 450/750 V



Construction:

Conductor:	flexible red or tinned copper conductor Cl.5, acc. to IEC 60228
Insulation:	PVC, type R2
Colour cores:	blue-black, with black progressively numbered
Stranding:	conductors twisted in pairs
Screen:	electrostatic screen of plastic and aluminium tape + tinned drain-wire
Armour:	braid of galvanized steel wires
Outer sheath:	black (RAL 9005), blue (RAL 5015) or grey (RAL 7001), PVC, type RZ

Resistance:



Flame retardant acc. to:
DIN VDE 0482 part 265-2-1
EN 50265-2-1
IEC 60332-1
EN 60332-3-24 CEI 20-22 III



Low smoke emission acc to:
CEI 20-37, IEC 60754

Technical data:

Nominal voltage:	up to 0,75 mm ² : Uo/U 300/500 V from 1 mm ² : Uo/U 450/750 V
Test voltage:	up to 0,75 mm ² : 2 kV from 1 mm ² : 2,5 kV
Temperature range:	-10 °C / + 70 °C
Min. bending radius:	10 x d

INSTRUMENTATION CABLES

FR2XOHRAR 450/750 V



Part no.	No. of pairs x cross section n x mm ²	Outer-Ø ca.mm ± 10%	Copper weight kg/km	Cable weight approx. kg/km	Inductance L (µH/m)
47030D.X022M05	2x2x0,50	9,5	24	129	0,90
47030D.X032M05	3x2x0,50	10	33,6	151	0,90
47030D.X042M05	4x2x0,50	11	43,2	175	0,90
47030D.X052M05	5x2x0,50	11,5	52,8	194	0,90
47030D.X062M05	6x2x0,50	12,5	62,4	229	0,90
47030D.X082M05	8x2x0,50	13,5	81,6	278	0,90
47030D.X102M05	10x2x0,50	15	100,8	332	0,90
47030D.X122M05	12x2x0,50	15,5	120	362	0,90
47030D.X162M05	16x2x0,50	18	158,4	467	0,90
47030D.X202M05	20x2x0,50	19,5	196,8	545	0,90
47030D.X242M05	24x2x0,50	21	234,8	653	0,90
47030D.X022M07	2x2x0,75	10,5	33,6	160	0,85
47030D.X032M07	3x2x0,75	11	48	181	0,85
47030D.X042M07	4x2x0,75	12,5	62,4	227	0,85
47030D.X052M07	5x2x0,75	13,5	76,8	262	0,85
47030D.X062M07	6x2x0,75	14,5	91,2	293	0,85
47030D.X082M07	8x2x0,75	15,5	120	355	0,85
47030D.X102M07	10x2x0,75	17,5	148,8	431	0,85
47030D.X122M07	12x2x0,75	18	177,6	488	0,85
47030D.X162M07	16x2x0,75	20,5	235,2	615	0,85
47030D.X202M07	20x2x0,75	21	292,8	748	0,85
47030D.X242M07	24x2x0,75	24	350,4	853	0,85
47030E.X022M10	2x2x1	11	43,2	176	0,85
47030E.X032M10	3x2x1	12	62,4	210	0,85
47030E.X042M10	4x2x1	13,5	81,6	266	0,85
47030E.X052M10	5x2x1	14,5	100,8	304	0,85
47030E.X062M10	6x2x1	15,5	120	348	0,85
47030E.X082M10	8x2x1	16,5	158,4	415	0,85
47030E.X102M10	10x2x1	18,5	196,8	510	0,85
47030E.X122M10	12x2x1	19,5	235,2	597	0,85
47030E.X162M10	16x2x1	22	312	743	0,85
47030E.X202M10	20x2x1	22,5	388,8	886	0,85
47030E.X242M10	24x2x1	26	464,8	1011	0,85
47030E.X022M15	2x2x1,50	13,5	62,4	246	0,85
47030E.X032M15	3x2x1,50	14	91,2	290	0,85
47030E.X042M15	4x2x1,50	15,5	120	347	0,85
47030E.X052M15	5x2x1,50	17	148,8	412	0,85
47030E.X062M15	6x2x1,50	18,5	177,6	485	0,85
47030E.X082M15	8x2x1,50	20	235,2	604	0,85
47030E.X102M15	10x2x1,50	22,5	292,8	732	0,85
47030E.X122M15	12x2x1,50	23	350,4	812	0,85
47030E.X162M15	16x2x1,50	26	464,8	1023	0,85
47030E.X202M15	20x2x1,50	26,5	580,8	1235	0,85
47030E.X242M15	24x2x1,50	30,5	696	1417	0,85

* The point inside the part number refers to the different colors in which outer sheath can be produced. Each color has different letter.

Other dimensions and colours available on request.

INSTRUMENTATION CABLES

FR2XHOHRAR 300/500 V



Construction:

Conductor:	flexible red or tinned copper conductor Cl.5, acc. to IEC 60228
Insulation:	PVC, type R2
Colour cores:	blue-black, with black progressively numbered
Stranding:	conductors twisted in pairs in concentric layers
Screen	
<i>Individual:</i>	electrostatic screen of plastic and aluminium tape + tinned drain-wire
<i>Overall:</i>	electrostatic screen of plastic and aluminium tape + tinned drain-wire
Armour:	braid of galvanized steel wires
Outer sheath:	black (RAL 9005), blue (RAL 5015) or grey (RAL 7001), PVC, type RZ

Resistance:



Flame retardant acc. to:
DIN VDE 0482 part 265-2-1
EN 50265-2-1
IEC 60332-1
EN 60332-3-24 CEI 20-22 III



Low smoke emission acc to:
CEI 20-37, IEC 60754

Technical data:

Nominal voltage:	up to 0,75 mm ² : U _o /U 300/500 V from 1 mm ² : U _o /U 450/750 V
Test voltage:	up to 0,75 mm ² : 2 kV from 1 mm ² : 2,5 kV
Temperature range	-10 °C / + 70 °C
Min. bending radius:	10 x d

INSTRUMENTATION CABLES

FR2XHOHRAR 300/500 V



Part no.	No. of pairs x cross section n x mm ²	Outer-Ø ca.mm ± 10%	Copper weight kg/km	Cable weight approx. kg/km	Inductance L (µH/m)
47040D.X022M05	2x2x0,50	7,5	33,6	68	0,90
47040D.X032M05	3x2x0,50	8	48	90	0,90
47040D.X042M05	4x2x0,50	8,5	62,4	110	0,90
47040D.X052M05	5x2x0,50	9,5	76,8	136	0,90
47040D.X062M05	6x2x0,50	10,5	91,2	162	0,90
47040D.X082M05	8x2x0,50	11,5	120	202	0,90
47040D.X102M05	10x2x0,50	13	148,8	253	0,90
47040D.X122M05	12x2x0,50	14	177,6	295	0,90
47040D.X162M05	16x2x0,50	15,5	235,2	383	0,90
47040D.X202M05	20x2x0,50	17,5	292,8	470	0,90
47040D.X242M05	24x2x0,50	18,5	350	547	0,90
47040D.X022M07	2x2x0,75	8,5	43,2	88	0,85
47040D.X032M07	3x2x0,75	9,5	62,4	117	0,85
47040D.X042M07	4x2x0,75	10	81,6	143	0,85
47040D.X052M07	5x2x0,75	11,3	96	178	0,85
47040D.X062M07	6x2x0,75	12,5	120	211	0,85
47040D.X082M07	8x2x0,75	13,5	158,4	272	0,85
47040D.X102M07	10x2x0,75	15,5	196,8	337	0,85
47040D.X122M07	12x2x0,75	16	235,2	387	0,85
47040D.X162M07	16x2x0,75	18,5	312	507	0,85
47040D.X202M07	20x2x0,75	20	388,8	614	0,85
47040D.X242M07	24x2x0,75	22	465,6	719	0,85
47040E.X022M10	2x2x1	9,5	52,8	106	0,85
47040E.X032M10	3x2x1	10	76,8	136	0,85
47040E.X042M10	4x2x1	11	100,8	176	0,85
47040E.X052M10	5x2x1	12,5	124,8	217	0,85
47040E.X062M10	6x2x1	13,5	148,8	256	0,85
47040E.X082M10	8x2x1	14,5	196,8	319	0,85
47040E.X102M10	10x2x1	17	244,8	404	0,85
47040E.X122M10	12x2x1	17,5	292,8	463	0,85
47040E.X162M10	16x2x1	20	388,8	599	0,85
47040E.X202M10	20x2x1	22	448,8	727	0,85
47040E.X242M10	24x2x1	24	580,8	844	0,85
47040E.X022M15	2x2x1,50	11,5	72	146	0,85
47040E.X032M15	3x2x1,50	12,5	105,6	196	0,85
47040E.X042M15	4x2x1,50	13,5	139,2	247	0,85
47040E.X052M15	5x2x1,50	15	172,8	303	0,85
47040E.X062M15	6x2x1,50	16,5	206,4	360	0,85
47040E.X082M15	8x2x1,50	18	273,6	455	0,85
47040E.X102M15	10x2x1,50	20,5	340,8	555	0,85
47040E.X122M15	12x2x1,50	21	408	639	0,85
47040E.X162M15	16x2x1,50	24	542,4	821	0,85
47040E.X202M15	20x2x1,50	26,5	676,8	1010	0,85
47040E.X242M15	24x2x1,50	29	811,2	1193	0,85

* The point inside the part number refers to the different colors in which outer sheath can be produced. Each color has different letter.

Other dimensions and colours available on request.

INSTRUMENTATION CABLES

RD-Y(st)Y



Construction:

Conductor:	stranded red copper conductor Cl. 2, acc. to IEC 60228, DIN VDE 0295
Insulation:	PVC compound
Colour cores:	PAIR 1: blue, red PAIR 2: grey, yellow PAIR 3: green, brown PAIR 4: white, black
Stranding:	conductors twisted in pairs, 4 pairs stranded to a unit, unit stranded in concentric layers
Screen:	electrostatic screen of plastic and aluminium tape + tinned drain-wire
Outer sheath:	grey (RAL 7000) or blue (RAL5015) PVC

Technical data:

Nominal voltage:	300 V
Test voltage:	2 kV
Temperature range	
<i>Fixed laying:</i>	- 30 °C / +70 °C
<i>Flexible application:</i>	- 5 °C / +50 °C
Min. bending radius:	10 x d

Resistance:



Flame retardant acc to:
DIN VDE 0482 part 265-2-1
EN 50265-2-1
IEC 60332-1-2 (equivalent DIN VDE 0472 part 804 test method B)

Features:

Suitable for-Maxi-Term-point-connection

the pairs are twisted with short pitches and different lay-lengths which lead to good cross talk attenuation values in a unit

the static screen protects the transmission circuits against outer electrical

the material used in manufacture are cadmium-free and contain no silicone and free from substances harmful to the wetting properties of lacquers

Conductor resistance:	max. 73,6 Ohm/km
Insulation resistance:	core/core min. 100 MOhm x km core/screen min. 100 MOhm x km
Mutual capacitance:	at 800 Hz max. 100 nF/km (this value may be exceeded by 20% with a make-up to 4 pairs)
Cross-talk attenuation:	at 10 kHz and cable length of 500 m min. 60 dB

Applications:

Connecting cable used in hand-held electric tools, for flexible and fixed installation.
Suitable in dry, humid or wet rooms.
Outdoor use within temperature range, no laying underground

Part no.	No. of pairs x cross section n x mm ²	Outer-Ø ca.mm ± 10%	Copper weight kg/km	Cable weight approx. kg/km	AWG no.®)
47050C.X022M05	2x2x0,5	7	29,8	65	20
47050C.X042M05	4x2x0,5	9	49,8	110	20
47050C.X082M05	8x2x0,5	12	89,8	180	20
47050C.X122M05	12x2x0,5	12,5	129,8	250	20
47050C.X162M05	16x2x0,5	14	169,8	310	20
47050C.X242M05	24x2x0,5	17,5	249,8	450	20
47050C.X322M05	32x2x0,5	21,5	329,8	560	20
47050C.X482M05	48x2x0,5	24	489,8	810	20

* The point inside the part number refers to the different colors in which outer sheath can be produced. Each color has different letter.

Other dimensions and colours available on request.

INSTRUMENTATION CABLES

REXOHR (PE/CAM/PVC)



Construction:

- Conductor:** stranded red copper conductor Cl. 2, acc to IEC 60228, DIN VDE 0295
- Insulation:** PE compound acc.to BS 6234
- Colour cores:** pair(s): blue-black, with black progressively numbers
triad(s): blue-brown-black, with black progressively numbered
- Stranding:** conductors twisted in pairs-triads.
pairs-triads twisted in layers
- Screen:** electrostatic screen of plastic and aluminium tape + tinned drain-wire
- Outer sheath:** blue (RAL 5015) or black (RAL 9005), PVC type TM1 acc. to BS 7655

Resistance:



- Flame retardant acc. to:**
EN 60332-1
IEC 60332-3-24 CEI 20-22 III
EN 50266-2-4
BS 4066

Technical data:

- Nominal voltage:** 300/500 V
- Test voltage:** 2 kV
- Temperature range:** - 30 °C / + 70 °C
- Max short circuit temperature:** +160°C

Features:

according to BS 5308-1

PAIRS:

Part no.	No. of pairs x cross section n x mm ²	Outer-Ø ca.mm ± 10%	Copper weight kg/km	Cable weight approx. kg/km	AWG no.®)
47060D.X012M05	1x2x0,50	7	14,4	61	20
47060D.X022M05	2x2x0,50	8	24	82	20
47060D.X052M05	5x2x0,50	13	52,8	206	20
47060D.X102M05	10x2x0,50	17	100,8	340	20
47060D.X202M05	20x2x0,50	22,3	196,8	569	20
47060D.X012M07	1x2x0,75	7,5	19,2	75	19
47060D.X022M07	2x2x0,75	8,3	33,6	97	19
47060D.X052M07	5x2x0,75	14,3	76,8	253	19
47060D.X102M07	10x2x0,75	18,7	148,8	447	19
47060D.X202M07	20x2x0,75	24,5	292	918	19
47060D.X012M10	1x2x1	7,5	24	85	18
47060D.X022M10	2x2x1	8,5	43,2	115	18
47060D.X052M10	5x2x1	14	100,8	291	18
47060D.X102M10	10x2x1	18,5	196,8	495	18
47060D.X202M10	20x2x1	24,5	388,8	950	18
47060E.X012M15	1x2x1,5	8,3	33,6	98	16
47060E.X022M15	2x2x1,5	10	62,4	156	16
47060E.X052M15	5x2x1,5	16,5	148,8	359	16
47060E.X102M15	10x2x1,5	21,5	292,8	670	16
47060E.X202M15	20x2x1,5	28,5	580,8	1231	16

TRIADS:

Part no.	No. of triples x cross section n x mm ²	Outer-Ø ca.mm ± 10%	Copper weight kg/km	Cable weight approx. kg/km	AWG no.®)
47060D.X013M05	1x3x0,50	7,3	19,2	68	20
47060D.X013M07	1x3x0,75	7,7	26,4	80	19
47060D.X013M10	1x3x1	7,7	33,6	104	18
47060D.X013M15	1x3x1,5	8,9	48	120	16

* The point inside the part number refers to the different colors in which outer sheath can be produced. Each color has different letter.

Other dimensions and colours available on request.

REXHOHR (PE/IAM/CAM/PVC)



Construction:

Conductor:	stranded red copper conductor Cl. 2, acc to IEC 60228, DIN VDE 0295
Insulation:	PE compound acc.to BS 6234
Colour cores:	blue-black, with black progressively numbered
Stranding:	conductors twisted in pairs
Screen	
<i>Individual:</i>	electrostatic screen of plastic and aluminium tape + tinned drain-wire
<i>Overall:</i>	electrostatic screen of plastic and aluminium tape + tinned drain-wire
Outer sheath:	blue (RAL 5015) or black (RAL 9005), PVC type TM1 acc. to BS 7655

Resistance:



Flame retardant acc. to:
EN 50266-2-4
EN 60332-1
IEC 60332-3-24 CEI 20-22 III
BS 4066

Technical data:

Nominal voltage:	300/500 V
Test voltage:	2 kV
Temperature range:	- 30 °C / + 70 °C
Max short circuit temperature:	+160°C

Features:

according to BS 5308-1
Possible variation/alternative performance:
- PE insulation or elastomeric compound G10 - G7 insulation
- Hydrocarbons resistant (ENI 0181) or halogen free thermoplastic compound HF M1 outer sheath
- U /U 300/500 0,6/1 kV (with loading of outside diameter)

INSTRUMENTATION CABLES

REXHOHR (PE/IAM/CAM/PVC)



Part no.	No. of pairs x cross section n x mm ²	Outer-Ø ca.mm ± 10%	Copper weight kg/km	Cable weight approx. kg/km	AWG no.*)
47070D.X042M05	4x2x0,50	11,2	-	62	20
47070D.X062M05	6x2x0,50	13,2	-	90	20
47070D.X082M05	8x2x0,50	14,4	-	119	20
47070D.X102M05	10x2x0,50	17,2	-	147	20
47070D.X122M05	12x2x0,50	17,7	-	176	20
47070D.X162M05	16x2x0,50	20,2	-	233	20
47070D.X202M05	20x2x0,50	22,2	-	290	20
47070D.X242M05	24x2x0,50	25,2	-	348	19
47070D.X022M07	2x2x0,75	10,4	43,2	115	19
47070D.X042M07	4x2x0,75	12	81,6	175	19
47070D.X062M07	6x2x0,75	14	120	250	19
47070D.X082M07	8x2x0,75	15,5	158,4	295	19
47070D.X102M07	10x2x0,75	19	196,8	420	19
47070D.X122M07	12x2x0,75	16,5	235,2	475	19
47070D.X162M07	16x2x0,75	21,6	312	600	19
47070D.X202M07	20x2x0,75	24,5	388,8	750	19
47070D.X242M07	24x2x0,75	27	465,6	875	19
47070D.X022M10	2x2x1	11,2	52,8	135	18
47070D.X042M10	4x2x1	13	100,8	205	18
47070D.X062M10	6x2x1	15,3	148,8	294	18
47070D.X082M10	8x2x1	17,3	196,8	380	18
47070D.X102M10	10x2x1	20,6	244,8	495	18
47070D.X202M10	20x2x1	26,5	448,8	895	18
47070D.X022M15	2x2x1,5	13	72	170	16
47070D.X042M15	4x2x1,5	15	139,2	275	16
47070D.X062M15	6x2x1,5	19,2	206,4	455	16
47070D.X082M15	8x2x1,5	21	273,6	540	16
47070D.X102M15	10x2x1,5	24,8	340,8	700	16
47070D.X202M15	20x2x1,5	32	811,2	1255	16

* The point inside the part number refers to the different colors in which outer sheath can be produced. Each color has different letter.

Other dimensions and colours available on request.

INSTRUMENTATION CABLES

RE-2Y(St)Yv



Construction:

Conductor:	stranded red copper conductor Cl. 2, acc. to IEC 60228, DIN VDE 0295
Insulation:	PE compound type 2Y11
Colour cores:	white-black, with black progressively numbered
Stranding:	conductors twisted in pairs
Screen:	electrostatic screen of plastic and aluminium tape + tinned drain-wire
Outer sheath:	blue (RAL 5015) or black (RAL 9005) PVC type TM1, outer sheath reinforced

Technical data:

Nominal voltage:	300/500 V
Test voltage:	2 kV
Temperature range:	- 30 °C / + 50 °C
Max short circuit temperature:	+160°C
Min. bending radius:	7,5 x d

Resistance:



Flame retardant and self-extinguishing acc.to:
PVC DIN VDE 0482 part 332-1-2
IEC 60332-1

Features:

Reinforced outer sheath

the electrostatic screen protect the screened pairs against outer electrostatic interference fields

low level of fine attenuation and low mutual capacitance enable long transmission distances and fast pulse acceleration

Conductor resistance: 0,5 mm²: max. 39,0 Ohm/km
0,75 mm²: max. 24,6 Ohm/km
1,3 mm²: max. 14,2 Ohm/km

Insulation resistance: min. 5 GOhm x km

Mutual capacitance: at 800 Hz
core/core 0,5 mm²: max. 60 nF/km
for 1 and 2 pairs: 75 nF/km
core/core 0,75 mm²: 65 nF/km
for 1 and 2 pairs: 110 nF/km
core/core 1,3 mm²: 75 nF/km
for 1 and 2 pairs: 100 nF/km

Cross-talk attenuation: max. 0,75 mH/km

Applications:

Instrumentation cables are used in data processing and process control and are suitable for fixed instalations in damp locations, in open locations, in open spaces and for underground laying.

INSTRUMENTATION CABLES

RE-2Y(St)Yv



BLACK:

Part no.	No. of pairs x cross section n x mm ²	Outer-Ø ca.mm ± 10%	Copper weight kg/km	Cable weight approx. kg/km	AWG no.®)
47080D7X012M05	1x2x0,5	7,5	15	74	20
47080D7X022M05	2x2x0,5	10,2	30	117	20
47080D7X042M05	4x2x0,5	11	50	140	20
47080D7X062M05	6x2x0,5	12,6	70	190	20
47080D7X082M05	8x2x0,5	13,8	90	215	20
47080D7X102M05	10x2x0,5	14,6	110	220	20
47080D7X122M05	12x2x0,5	15,7	130	280	20
47080D7X162M05	16x2x0,5	17,5	170	352	20
47080D7X202M05	20x2x0,5	18,5	210	385	20
47080D7X242M05	24x2x0,5	20,2	270	468	20
47080D7X362M05	36x2x0,5	24	370	656	20
47080D7X482M05	48x2x0,5	27,4	490	854	20
47080D7X012M07	1x2x0,75	7,9	20	74	19
47080D7X022M07	2x2x0,75	10,6	35	123	19
47080D7X042M07	4x2x0,75	11,7	65	164	19
47080D7X082M07	8x2x0,75	14,6	125	258	19
47080D7X102M07	10x2x0,75	15,8	154	305	19
47080D7X162M07	16x2x0,75	19	245	445	19
47080D7X202M07	20x2x0,75	21,5	298	520	19
47080D7X242M07	24x2x0,75	23,2	365	620	19
47080D7X362M07	36x2x0,75	28,2	532	940	19
47080D7X482M07	48x2x0,75	32	708	1250	19
47080D7X012M13	1x2x1,3	8,8	31	102	16
47080D7X022M13	2x2x1,3	11,7	62	161	16
47080D7X042M13	4x2x1,3	13,5	114	230	16
47080D7X062M13	6x2x1,3	16	168	310	16
47080D7X082M13	8x2x1,3	16,8	218	377	16
47080D7X122M13	12x2x1,3	19,3	322	515	16
47080D7X162M13	16x2x1,3	22	426	656	16
47080D7X242M13	24x2x1,3	26,5	684	952	16

INSTRUMENTATION CABLES

RE-2Y(St)Yv



BLUE:

Part no.	No. of pairs x cross section n x mm ²	Outer-Ø ca.mm ± 10%	Copper weight kg/km	Cable weight approx. kg/km	AWG no.®)
47080DBX012M05	1x2x0,5	7,5	15	74	20
47080DBX022M05	2x2x0,5	10,2	30	117	20
47080DBX042M05	4x2x0,5	11	50	140	20
47080DBX062M05	6x2x0,5	12,6	70	190	20
47080DBX082M05	8x2x0,5	13,8	90	215	20
47080DBX102M05	10x2x0,5	14,6	110	220	20
47080DBX122M05	12x2x0,5	15,7	130	280	20
47080DBX162M05	16x2x0,5	17,5	170	352	20
47080DBX202M05	20x2x0,5	18,5	210	385	20
47080DBX242M05	24x2x0,5	20,2	270	468	20
47080DBX362M05	36x2x0,5	24	370	656	20
47080DBX482M05	48x2x0,5	27,4	490	854	20
47080DBX012M07	1x2x0,75	7,9	20	74	19
47080DBX022M07	2x2x0,75	10,6	35	123	19
47080DBX042M07	4x2x0,75	11,7	65	164	19
47080DBX082M07	8x2x0,75	14,6	125	258	19
47080DBX102M07	10x2x0,75	15,8	154	305	19
47080DBX162M07	16x2x0,75	19	245	445	19
47080DBX202M07	20x2x0,75	21,5	298	520	19
47080DBX242M07	24x2x0,75	23,2	365	620	19
47080DBX362M07	36x2x0,75	28,2	532	940	19
47080DBX482M07	48x2x0,75	32	708	1250	19
47080DBX012M13	1x2x1,3	8,8	31	102	16
47080DBX022M13	2x2x1,3	11,7	62	161	16
47080DBX042M13	4x2x1,3	13,5	114	230	16
47080DBX062M13	6x2x1,3	16,0	168	310	16
47080DBX08M13	8x2x1,3	16,8	218	377	16
47080DBX122M13	12x2x1,3	19,3	322	515	16
47080DBX162M13	16x2x1,3	22	426	656	16
47080DBX242M13	24x2x1,3	26,5	684	952	16

Other dimensions and colours available on request.

RE-2Y(St)Yv-fl



Construction:

Conductor:	stranded red copper conductor Cl. 2, acc to IEC 60228, DIN VDE 0295
Insulation:	PE compound
Colour cores:	white-black, with black progressively numbered
Stranding:	conductors twisted in pairs
Screen:	electrostatic screen of plastic and aluminium tape + tinned drain-wire
Outer sheath:	blue (RAL 5015) or black (RAL 9005) PVC compound, outer sheath reinforced

Technical data:

Nominal voltage:	300/500 V
Test voltage:	2 kV
Temperature range:	- 30 °C / + 70 °C
Max short circuit temperature:	+160°C
Min. bending radius:	7,5 x d

Resistance:



Flame retardant and self-extinguishing acc.to:
PVC DIN VDE 0482 part 266-2-4
EN 50266-2-4
IEC 60332-3-24

Features:

the electrostatic screen protect the screened pairs against outer electrostatic interference fields

low level of fine attenuation and low mutual capacitance enable long transmission distances and fast pulse acceleration

Conductor resistance:	0,5 mm ² : max. 39,0 Ohm/km 0,75 mm ² : max. 24,6 Ohm/km 1,3 mm ² : max. 14,2 Ohm/km
------------------------------	---

Insulation resistance:	min. 5 GOhm x km
-------------------------------	------------------

Mutual capacitance:	at 800 Hz core/core 0,5 mm ² : max. 60 nF/km for 1 and 2 pairs: 75 nF/km core/core 0,75 mm ² : 65 nF/km for 1 and 2 pairs: 110 nF/km core/core 1,3 mm ² : 75 nF/km for 1 and 2 pairs: 100 nF/km
----------------------------	--

Inductance:	max. 0,75 mH/km
--------------------	-----------------

Cross-talk attenuation:	max. 0,75 mH/km
--------------------------------	-----------------

Applications:

Instrumentation cables are used in data processing and process control and are suitable for fixed installations in damp locations, in open locations, in open spaces and for underground laying.

INSTRUMENTATION CABLES

RE-2Y(St)Yv-fl



BLACK:

Part no.	No. of pairs/triples x cross section n x mm ²	Outer-Ø ca.mm ± 10%	Copper weight kg/km	Cable weight approx. kg/km	AWG no.*)
47090D7X012M05	1x2x0,5	7,5	15	74	20
47090D7X022M05	2x2x0,5	10,2	30	117	20
47090D7X042M05	4x2x0,5	11,0	50	140	20
47090D7X062M05	6x2x0,5	12,6	70	190	20
47090D7X082M05	8x2x0,5	13,8	90	215	20
47090D7X102M05	10x2x0,5	14,6	110	220	20
47090D7X122M05	12x2x0,5	15,7	130	280	20
47090D7X162M05	16x2x0,5	17,5	170	352	20
47090D7X202M05	20x2x0,5	18,5	210	385	20
47090D7X242M05	24x2x0,5	20,2	270	468	20
47090D7X362M05	36x2x0,5	24,0	370	656	20
47090D7X482M05	48x2x0,5	27,4	490	854	20
47090D7X012M07	1x2x0,75	7,9	20	74	19
47090D7X022M07	2x2x0,75	10,6	35	123	19
47090D7X042M07	4x2x0,75	11,7	65	164	19
47090D7X082M07	8x2x0,75	14,6	125	258	19
47090D7X102M07	10x2x0,75	15,8	154	305	19
47090D7X122M07	12x2x0,75	17,0	185	350	19
47090D7X162M07	16x2x0,75	19,0	245	445	19
47090D7X202M07	20x2x0,75	21,5	298	520	19
47090D7X242M07	24x2x0,75	23,2	365	620	19
47090D7X362M07	36x2x0,75	28,2	532	940	19
47090D7X482M07	48x2x0,75	32,0	708	1250	19
47090D7X012M13	1x2x1,3	8,8	31	102	16
47090D7X022M13	2x2x1,3	11,7	62	161	16
47090D7X042M13	4x2x1,3	13,5	114	230	16
47090D7X062M13	6x2x1,3	16,0	168	310	16
47090D7X08M13	8x2x1,3	16,8	218	377	16
47090D7X122M13	12x2x1,3	19,3	322	515	16
47090D7X162M13	16x2x1,3	22,0	426	656	16
47090D7X023M05	2x3x0,5	13	70	200	20

INSTRUMENTATION CABLES

RE-2Y(St)Yv-fl



BLUE:

Part no.	No. of pairs/triples x cross section n x mm ²	Outer-Ø ca.mm ± 10%	Copper weight kg/km	Cable weight approx. kg/km	AWG no.®)
47090DBX022M05	2x2x0,5	10,2	30	117	20
47090DBX042M05	4x2x0,5	11,0	50	140	20
47090DBX062M05	6x2x0,5	12,6	70	190	20
47090DBX082M05	8x2x0,5	13,8	90	215	20
47090DBX102M05	10x2x0,5	14,6	110	220	20
47090DBX122M05	12x2x0,5	15,7	130	280	20
47090DBX162M05	16x2x0,5	17,5	170	352	20
47090DBX202M05	20x2x0,5	18,5	210	385	20
47090DBX242M05	24x2x0,5	20,2	270	468	20
47090DBX362M05	36x2x0,5	24,0	370	656	20
47090DBX482M05	48x2x0,5	27,4	490	854	20
47090DBX012M07	1x2x0,75	7,9	20	74	19
47090DBX022M07	2x2x0,75	10,6	35	123	19
47090DBX042M07	4x2x0,75	11,7	65	164	19
47090DBX082M07	8x2x0,75	14,6	125	258	19
47090DBX102M07	10x2x0,75	15,8	154	305	19
47090DBX122M07	12x2x0,75	17,0	185	350	19
47090DBX162M07	16x2x0,75	19,0	245	445	19
47090DBX202M07	20x2x0,75	21,5	298	520	19
47090DBX242M07	24x2x0,75	23,2	365	620	19
47090DBX362M07	36x2x0,75	28,2	532	940	19
47090DBX482M07	48x2x0,75	32,0	708	1250	19
47090DBX012M13	1x2x1,3	8,8	31	102	16
47090DBX022M13	2x2x1,3	11,7	62	161	16
47090DBX042M13	4x2x1,3	13,5	114	230	16
47090DBX062M13	6x2x1,3	16,0	168	310	16
47090DBX08M13	8x2x1,3	16,8	218	377	16
47090DBX122M13	12x2x1,3	19,3	322	515	16
47090DBX162M13	16x2x1,3	22,0	426	656	16
47090DBX023M05	2x3x0,5	13	70	200	20

Other dimensions and colours available on request.

INSTRUMENTATION CABLES

RE-2Y(St)Y PiMF or TiMF

Screened multi pair, PE insulated, PVC sheath



Construction:

Conductor:	stranded red copper conductor Cl. 2, acc. to IEC 60228, DIN VDE 0295
Insulation:	PE type 2Y11
Colour cores:	PAIR: black, white TRIAD: black, white, red
Stranding:	conductors twisted in pairs/triads
Screen	
<i>Individual:</i>	electrostatic screen of plastic and aluminium tape + tinned drain-wire
<i>Overall:</i>	electrostatic screen of plastic and aluminium tape + tinned drain-wire
Outer sheath:	blue (RAL 5015) or black (RAL 9005) PVC type YM1

Technical data:

Nominal voltage:	300/500 V
Test voltage:	2 kV
Temperature range:	- 30 °C / + 70 °C
Max short circuit temperature:	+160°C
Min. bending radius:	7,5 x d

Resistance:



Flame retardant and self-extinguishing acc.to:
IEC 60332-1

Features:

fl: on request

standard TS/DIN EN 50288-7

Insulation thickness:	mm	0,50	0,75	1	1,3	1,5
	mm	0,40	0,40	0,40	0,45	0,45
Insulation thickness:	mm	0,50	0,75	1	1,3	1,5
	Ohm/km	36,7	25	18,5	14,2	12,3

Insulation resistance: min. 5 GOhm x km

Mutual capacitance:	≤ 4 pairs	all other pairs
	0,50 mm ² : max. 115 pF/m	max. 90 pF/m
	0,75 mm ² : max. 115 pF/m	max. 90 pF/m
	1,0 mm ² : max. 115 pF/m	max. 90 pF/m
	1,3 mm ² : max. 120 pF/m	max. 105 pF/m
	1,5 mm ² : max. 120 pF/m	max. 105 pF/m

Capacitance unbalance: (1 kHz): max. 500 pF/500 m

L/R (oran-ratio) (max.):	mm ²	0,50	0,75	1,0	1,3	1,5
	mm ²	25	25	25	40	40

Applications:

These cables are used for transmission of analogue and digital signals in instrument and control systems at chemistry and petrochemistry industry plants, natural gas and petroleum plants. With blue sheath it is suitable for intrinsically safe systems. these cables are for indoor/outdoor installation, in dry and wet locations, on rack trays, in conduits.

INSTRUMENTATION CABLES

RE-2Y(St)Y PiMF or TiMF

Screened multi pair, PE insulated, PVC sheath



Part no.	No. of pairs/triples x cross section n x mm ²	Outer-Ø ca.mm ± 10%	Copper weight kg/km	Cable weight approx. kg/km	AWG no.®)
47100D.X022M05	2x2x0,50	9,8	-	33	20
47100D.X042M05	4x2x0,50	11,2	-	62	20
47100D.X062M05	6x2x0,50	13,2	-	90	20
47100D.X082M05	8x2x0,50	14,4	-	119	20
47100D.X102M05	10x2x0,50	17,2	-	147	20
47100D.X122M05	12x2x0,50	17,7	-	176	20
47100D.X162M05	16x2x0,50	20,2	-	233	20
47100D.X202M05	20x2x0,50	22,2	-	290	20
47100D.X242M05	24x2x0,50	25,2	-	348	19
47100D.X022M07	2x2x0,75	10,4	43,2	115	19
47100D.X042M07	4x2x0,75	12	81,6	175	19
47100D.X062M07	6x2x0,50	14	120	250	19
47100D.X082M07	8x2x0,50	15,5	158,4	295	19
47100D.X102M07	10x2x0,75	19	196,8	420	19
47100D.X122M07	12x2x0,75	16,5	235,2	475	19
47100D.X162M07	16x2x0,75	21,6	312	600	19
47100D.X202M07	20x2x0,75	24,5	388,8	750	19
47100D.X242M07	24x2x0,75	27	465,6	875	19
47100D.X022M10	2x2x1	11,2	52,8	135	18
47100D.X042M10	4x2x1	13	100,8	205	18
47100D.X062M10	6x2x1	15,3	148,8	294	18
47100D.X082M10	8x2x1	17,3	196,8	380	18
47100D.X102M10	10x2x1	20,6	244,8	495	18
47100D.X202M10	20x2x1	26,5	448,8	895	18
47100D.X022M15	2x2x1,5	13	72	170	16
47100D.X042M15	4x2x1,5	15	139,2	275	16
47100D.X062M15	6x2x1,5	19,2	206,4	455	16
47100D.X082M15	8x2x1,5	21	273,6	540	16
47100D.X102M15	10x2x1,5	24,8	340,8	700	16
47100D.X202M15	20x2x1,5	32	811,2	1255	16
47100D.X123M05	12x3x0,5	19,4	235	410	20

* The point inside the part number refers to the different colors in which outer sheath can be produced. Each color has different letter.

Other dimensions and colours available on request.

RE-2Y(St)Yv PiMF



ELETTROTEK KABEL® RE-2Y(st)Yv PiMF

ELETTROTEK KABEL® RE-2Y(st)Yv PiMF



Construction:

Conductor:	stranded red copper conductor Cl. 2, acc to IEC 60228, DIN VDE 0295
Insulation:	PE compound
Colour cores:	white-black, with black progressively numbered
Stranding:	conductors twisted in pairs, PiMF (pair in metal foil), foil taping, drain-wire, Cu-bare 0,6 mm, plastic coated alu-foil and plastic foil, PiMF stranded in layer, 1 communication core PE-insulation orange
Screen	
<i>Individual:</i>	electrostatic screen of plastic and aluminium tape + tinned drain-wire
<i>Overall:</i>	electrostatic screen of plastic and aluminium tape + tinned drain-wire
Outer sheath:	blue (RAL 5015) or black (RAL 9005) reinforced PVC compound, low smoke and low halogen compound

Technical data:

Nominal voltage:	300 V
Test voltage:	core/core 2 kV core/screen 1 kV
Temperature range	
<i>Fixed laying:</i>	- 40 °C / + 70 °C
<i>Flexible application:</i>	- 5 °C / + 70 °C
Min. bending radius:	7,5 x d

Resistance:



Flame retardant and self-extinguishing acc.to:

PVC DIN VDE 0482 part 332-1-2
IEC 60332-1
EN 60332-1

Features:

fl: on request

Conductor resistance:	0,5 mm ² : max. 39,0 Ohm/km 1,3 mm ² : max. 14,2 Ohm/km
Insulation resistance:	min. 5 GOhm x km
Mutual capacitance:	at 800 Hz core/core 0,5 mm : 75 nF/km core/core 1,3 mm : 100 nF/km
Inductance:	max. 0,75 mH/km
Cross-talk attenuation:	min 1,02 dB/kmat 60 kHz

Applications:

Instrumentation cables are used in data processing and process control and are suitable for fixed installations in damp locations, in open locations, in open spaces and for underground laying.

INSTRUMENTATION CABLES

RE-2Y(St)Yv PiMF



ELETTROTEK KABEL® RE-2Y(st)Yv PiMF

ELETTROTEK KABEL® RE-2Y(st)Yv PiMF

BLACK:

Part no.	No. of pairs x cross section n x mm ²	Outer-Ø ca.mm ± 10%	Copper weight kg/km	Cable weight approx. kg/km	AWG no.®)
47110C7X022M05	2x2x0,5	12	35	128	20
47110C7X042M05	4x2x0,5	12,7	60	170	20
47110C7X062M05	6x2x0,5	14	82	215	20
47110C7X082M05	8x2x0,5	14,9	121	246	20
47110C7X102M05	10x2x0,5	16,4	136	261	20
47110C7X122M05	12x2x0,5	17,6	161	351	20
47110C7X162M05	16x2x0,5	19,8	212	430	20
47110C7X202M05	20x2x0,5	21,2	262	496	20
47110C7X242M05	24x2x0,5	23,6	313	604	20
47110C7X362M05	36x2x0,5	26,9	465	850	20
47110C7X482M05	48x2x0,5	32,2	616	1115	20
47110C7X022M13	2x2x1,3	12,7	68	184	16
47110C7X042M13	4x2x1,3	15,2	124	269	16
47110C7X062M13	6x2x1,3	16,7	178	370	16
47110C7X082M13	8x2x1,3	18,8	239	442	16
47110C7X122M13	12x2x1,3	21,4	353	593	16
47110C7X162M13	16x2x1,3	24,7	468	789	16
47110C7X242M13	24x2x1,3	29,4	697	1104	16

BLUE:

Part no.	No. of pairs x cross section n x mm ²	Outer-Ø ca.mm ± 10%	Copper weight kg/km	Cable weight approx. kg/km	AWG no.®)
47110CBX022M05	2x2x0,5	12	35	128	20
47110CBX042M05	4x2x0,5	12,7	60	170	20
47110CBX062M05	6x2x0,5	14	82	215	20
47110CBX082M05	8x2x0,5	14,9	121	246	20
47110CBX102M05	10x2x0,5	16,4	136	261	20
47110CBX122M05	12x2x0,5	17,6	161	351	20
47110CBX162M05	16x2x0,5	19,8	212	430	20
47110CBX202M05	20x2x0,5	21,2	262	496	20
47110CBX242M05	24x2x0,5	23,6	313	604	20
47110CBX362M05	36x2x0,5	26,9	465	850	20
47110CBX482M05	48x2x0,5	32,2	616	1115	20
47110CBX022M13	2x2x1,3	12,7	68	184	16
47110CBX042M13	4x2x1,3	15,2	124	269	16
47110CBX062M13	6x2x1,3	16,7	178	370	16
47110CBX082M13	8x2x1,3	18,8	239	442	16
47110CBX122M13	12x2x1,3	21,4	353	593	16
47110CBX162M13	16x2x1,3	24,7	468	789	16
47110CBX242M13	24x2x1,3	29,4	697	1104	16

Other dimensions and colours available on request.

INSTRUMENTATION CABLES

RE-2Y(St)YRY

Screened/armouring single and multi pair, PE insulated, PVC sheath



Construction:

Conductor:	stranded red copper conductor Cl. 2, acc to IEC 60228, DIN VDE 0295
Insulation:	PE type 2Y11
Colour cores:	white-black, with black progressively numbered
Stranding:	conductors twisted in pairs
Wrapping:	Polyester tape
Screen:	electrostatic screen of plastic and aluminium tape + tinned drain-wire
Inner sheath:	PVC type YM1
Armour:	galvanized steel wires
Outer sheath:	black (RAL 9005), or blue (RAL 5015) PVC type YM1

Technical data:

Nominal voltage:	300/500 V
Test voltage:	1,5 kV
Temperature range:	- 30 °C / + 70 °C
Min. bending radius:	7,5 x d

Resistance:



Flame retardant and self-extinguishing acc.to:
IEC 60332-1

Features:

fl: on request

standard TS/DIN EN 50288-7

Insulation thickness:	mm	0,50	0,75	1	1,3	1,5
	mm	0,40	0,40	0,40	0,45	0,45
Conductor resistance:	mm	0,50	0,75	1	1,3	1,5
	Ohm/km	36,7	25	18,5	14,2	12,3
Insulation resistance:	min. 5 GOhm x km					
Mutual capacitance:	≤ 4 pairs		all other pairs			
	0,50 mm ² :	max. 115 pF/m	max. 90 pF/m			
	0,75 mm ² :	max. 115 pF/m	max. 90 pF/m			
	1,0 mm ² :	max. 115 pF/m	max. 90 pF/m			
	1,3 mm ² :	max. 120 pF/m	max. 105 pF/m			
	1,5 mm ² :	max. 120 pF/m	max. 105 pF/m			
Capacitance unbalance:	(1 kHz): max. 500 pF/500 m					
L/R (oran-ratio) (max.):	mm ²	0,50	0,75	1,0	1,3	1,5
	mm ²	25	25	25	40	40

Applications:

These cables are used for transmission of analogue and digital signals in instrument and control systems at chemistry and petrochemistry industry plants, natural gas and petroleum plants. With blue sheath it is suitable for intrinsically safe systems. these cables are for indoor/outdoor installation, in dry and wet locations, on rack trays, in conduits.

INSTRUMENTATION CABLES

RE-2Y(St)YRY

Screened/armouring single and multi pair, PE insulated, PVC sheath



Part no.	No. of pairs x cross section n x mm ²	Outer-Ø ca.mm ± 10%	Copper weight kg/km	Cable weight approx. kg/km	AWG no.®)
47120D.X022M05	2x2x0,50	12,5	30	300	20
47120D.X042M05	4x2x0,50	13,5	50	360	20
47120D.X082M05	8x2x0,50	18	90	590	20
47120D.X122M05	12x2x0,50	20,5	130	790	20
47120D.X162M05	16x2x0,50	23	170	1030	20
47120D.X242M05	24x2x0,50	27,5	270	1370	19
47120D.X022M07	2x2x0,75	13	35	330	19
47120D.X042M07	4x2x0,75	14,5	65	400	19
47120D.X082M07	8x2x0,75	19,5	125	700	19
47120D.X122M07	12x2x0,75	23	185	1020	19
47120D.X162M07	16x2x0,75	25,5	245	1240	19
47120D.X242M07	24x2x0,75	30,5	365	1620	19
47120D.X022M10	2x2x1	13,5	43,2	375	18
47120D.X042M10	4x2x1	16,5	81,6	535	18
47120D.X082M10	8x2x1	21	158,4	795	18
47120D.X122M10	12x2x1	25,5	235,2	1230	18
47120D.X162M10	16x2x1	27,5	312	1420	18
47120D.X242M10	24x2x1	33	464,8	1900	18
47120D.X022M15	2x2x1,5	16,5	62,4	525	16
47120D.X042M15	4x2x1,5	19,5	120	960	16
47120D.X082M15	8x2x1,5	21,5	235,2	1230	16
47120D.X122M15	12x2x1,5	28,7	350,4	1530	16
47120D.X162M15	16x2x1,5	32,1	464,8	1885	16
47120D.X242M15	24x2x1,5	41,5	696	3270	16

* The point inside the part number refers to the different colors in which outer sheath can be produced. Each color has different letter.

Other dimensions and colours available on request.

INSTRUMENTATION CABLES

RE-2Y(St)YRY

Screened/armouring multi core, PE insulated, PVC sheath



Construction:

Conductor:	stranded red copper conductor Cl. 2, acc to IEC 60228, DIN VDE 0295
Insulation:	PE type 2Y11
Colour cores:	black numbered
Stranding:	in layers of optimum pitch
Wrapping:	Polyester tape over solid tinned copper drain wire, 0,60 mm
Screen:	electrostatic screen of plastic and aluminium tape + tinned drain-wire
Inner sheath:	PVC type YM1
Armour:	galvanized steel wires
Outer sheath:	black (RAL 9005), or blue (RAL 5015) PVC type YM1

Resistance:



Flame retardant and self-extinguishing acc.to:
IEC 60332-1

Features:

fl: on request

standard TS/DIN EN 50288-7

Insulation resistance: min. 5 GOhm x km

Mutual capacitance: max. 120 pF/m

Conductor resistance: 0,5 mm²: max. 39,0 Ohm/km
1,3 mm²: max. 14,2 Ohm/km

L/R (oran-ratio) (max.):	mm ²	0,50	0,75	1,0	1,3	1,5
	mm ²	25	25	25	40	40

Technical data:

Nominal voltage:	300/500 V
Test voltage:	1,5 kV
Temperature range:	- 30 °C / + 70 °C
Min. bending radius:	7,5 x d

Applications:

These cables are used for transmission of analogue and digital signals in instrument and control systems at chemistry and petrochemistry industry plants, natural gas and petroleum plants. With blue sheath it is suitable for intrinsically safe systems. these cables are for indoor/outdoor installation, in dry and wet locations, on rack trays, in conduits.

INSTRUMENTATION CABLES

RE-2Y(St)YRY

Screened/armouring multi core, PE insulated, PVC sheath



Part no.	No. of cores x cross section n x mm ²	Outer-Ø ca. mm ± 10%	Copper weight kg/km	Cable weight approx. kg/km	AWG no. *)
47120D.1020M05	2x0,50	10,8	14	225	20
47120D.1030M05	3x0,50	11,3	19	250	20
47120D.1040M05	4x0,50	11,8	24	280	20
47120D.1050M05	5x0,50	12,4	29	315	20
47120D.1060M05	6x0,50	13	34	345	20
47120D.1080M05	8x0,50	13,9	43	400	20
47120D.1100M05	10x0,50	15,2	53	470	20
47120D.1120M05	12x0,50	15,5	62	505	20
47120D.1140M05	14x0,50	16	72	550	20
47120D.1160M05	16x0,50	16,6	82	600	20
47120D.1200M05	20x0,50	17,9	101	695	20
47120D.1240M05	24x0,50	19,4	120	800	20
47120D.1270M05	27x0,50	19,7	134	855	20
47120D.1300M05	30x0,50	20,9	149	1015	20
47120D.1370M05	37x0,50	22,1	182	1160	20
47120D.1400M05	40x0,50	23	197	1240	20
47120D.1020M07	2x0,75	11,4	19	250	19
47120D.1030M07	3x0,75	11,8	26	280	19
47120D.1040M07	4x0,75	12,3	34	320	19
47120D.1050M07	5x0,75	12,9	41	355	19
47120D.1060M07	6x0,75	13,4	48	390	19
47120D.1080M07	8x0,75	14,8	62	470	19
47120D.1100M07	10x0,75	16	77	545	19
47120D.1120M07	12x0,75	16,4	91	595	19
47120D.1140M07	14x0,75	16,9	106	655	19
47120D.1160M07	16x0,75	17,5	120	710	19
47120D.1060M07	20x0,75	19,1	149	840	19
47120D.1240M07	24x0,75	21,3	178	1075	19
47120D.1270M07	27x0,75	21,6	199	1145	19
47120D.1300M07	30x0,75	22,2	221	1230	19
47120D.1370M07	37x0,75	23,7	271	1430	19
47120D.1400M07	40x0,75	24,4	293	1515	19
47120D.1020M10	2x1	11,8	24	275	18
47120D.1030M10	3x1	12,2	34	310	18
47120D.1040M10	4x1	12,8	43	355	18
47120D.1050M10	5x1	13,5	53	400	18
47120D.1060M10	6x1	14,2	62	445	18
47120D.1080M10	8x1	15,5	82	535	18
47120D.1100M10	10x1	16,8	101	625	18
47120D.1120M10	12x1	17,2	120	690	18
47120D.1140M10	14x1	17,8	139	760	18
47120D.1160M10	16x1	18,5	158	830	18
47120D.1200M10	20x1	20,9	197	1090	18
47120D.1240M10	24x1	22,7	235	1260	18
47120D.1270M10	27x1	23,1	264	1355	18
47120D.1300M10	30x1	23,7	293	1455	18
47120D.1370M10	37x1	25,1	360	1690	18
47120D.1400M10	40x1	26,1	388	1805	18

INSTRUMENTATION CABLES

RE-2Y(St)YRY

Screened/armouring multi core, PE insulated, PVC sheath



Part no.	No. of cores x cross section n x mm ²	Outer-Ø ca. mm ± 10%	Copper weight kg/km	Cable weight approx. kg/km	AWG no. *)
47120D.1020M13	2x1,3	12,3	30	300	17
47120D.1030M13	3x1,3	12,7	42	350	17
47120D.1030M13	4x1,3	13,4	55	400	17
47120D.1050M13	5x1,3	14,2	67	455	17
47120D.1060M13	6x1,3	15,2	80	515	17
47120D.1080M13	8x1,3	16,3	105	615	17
47120D.1100M13	10x1,3	17,8	130	725	17
47120D.1120M13	12x1,3	18,2	155	805	17
47120D.1140M13	14x1,3	19,1	180	895	17
47120D.1160M13	16x1,3	20,6	204	1090	17
47120D.1200M13	20x1,3	22,2	254	1280	17
47120D.1240M13	24x1,3	24,2	304	1490	17
47120D.1270M13	27x1,3	24,6	342	1600	17
47120D.1300M13	30x1,3	25,3	379	1725	17
47120D.1370M13	37x1,3	27,1	467	2025	17
47120D.1400M13	40x1,3	27,9	504	2160	17
47120D.1020M15	2x1,5	12,6	34	320	16
47120D.1030M15	3x1,5	13,0	48	370	16
47120D.1030M15	4x1,5	13,8	62	430	16
47120D.1050M15	5x1,5	14,6	77	490	16
47120D.1060M15	6x1,5	15,6	91	555	19
47120D.1080M15	8x1,5	16,9	120	670	19
47120D.1100M15	10x1,5	18,4	149	790	19
47120D.1120M15	12x1,5	19,0	178	885	19
47120D.1130M15	14x1,5	19,7	206	980	19
47120D.1160M15	16x1,5	21,3	235	1185	19
47120D.1200M15	20x1,5	23,2	293	1410	19
47120D.1240M15	24x1,5	25,1	350	1630	19
47120D.1270M15	27x1,5	25,5	394	1760	19
47120D.1300M15	30x1,5	26,4	437	1910	19
47120D.1370M15	37x1,5	28,1	538	2235	19
47120D.1400M15	40x1,5	29,0	581	2385	19
47120D.1020M25	2x2,5	13,8	34	360	18
47120D.1030M25	3x2,5	14,3	48	420	18
47120D.1040M25	4x2,5	15,4	62	490	18
47120D.1050M25	5x2,5	16,4	77	560	18
47120D.1060M25	6x2,5	17,4	91	630	18
47120D.1080M25	8x2,5	19,1	120	765	18
47120D.1100M25	10x2,5	21,7	149	1010	18
47120D.1120M25	12x2,5	22,2	178	1115	18
47120D.1140M25	14x2,5	23,3	206	1237	18
47120D.1160M25	16x2,5	24,3	235	1355	18
47120D.1200M25	20x2,5	26,4	293	1600	18
47120D.1240M25	24x2,5	28,9	350	1860	18
47120D.1270M25	27x2,5	29,4	394	2000	18
47120D.1300M25	30x2,5	30,5	437	2170	18
47120D.1370M25	37x2,5	33,2	538	2715	18
47120D.1400M25	40x2,5	34,9	581	2945	18

* The point inside the part number refers to the different colors in which outer sheath can be produced. Each color has different letter.

Other dimensions and colours available on request.

INSTRUMENTATION CABLES

RE-2Y(St)YRY PiMF

Screened/armouring multi pair, PE insulated, PVC sheath



Construction:

Conductor:	stranded red copper conductor Cl. 2, acc to IEC 60228, DIN VDE 0295
Insulation:	PE type 2Y11
Colour cores:	white-black, with black progressively numbered
Stranding:	conductors twisted in pairs, PiMF laid up in layers of optimum pitch
Wrapping:	(PiMF) Polyester tape above the pair, AL-PES tape over solid tinned copper drain wire, 0,60 mm
Screen	
<i>Individual:</i>	electrostatic screen of plastic and aluminium tape + tinned drain-wire
<i>Overall:</i>	electrostatic screen of plastic and aluminium tape + tinned drain-wire
Inner sheath:	PVC compound
Armour:	galvanized steel wires
Outer sheath:	black (RAL 9005), or blue (RAL 5015) PVC type YM1

Resistance:



Flame retardant and self-extinguishing acc.to:
IEC 60332-1

Features:

fl: on request

standard TS/DIN EN 50288-7

Insulation thickness:	mm	0,50	0,75	1	1,3	1,5
	mm	0,40	0,40	0,40	0,45	0,45
Conductor resistance:	mm	0,50	0,75	1	1,3	1,5
	Ohm/km	36,7	25	18,5	14,2	12,3
Insulation resistance:	min. 5 GOhm x km					
Mutual capacitance:	max. 120 pF/m					
Capacitance unbalance:	(1 kHz): max. 500 pF/500 m					
L/R (oran-ratio) (max.):	mm ²	0,50	0,75	1,0	1,3	1,5
	mm ²	25	25	25	40	40

Technical data:

Nominal voltage:	300/500 V
Test voltage:	2 kV
Temperature range:	- 30 °C / + 70 °C
Min. bending radius:	7,5 x d

Applications:

These cables are used for transmission of analogue and digital signals in instrument and control systems at chemistry and petrochemistry industry plants, natural gas and petroleum plants. With blue sheath it is suitable for intrinsically safe systems. these cables are for indoor/outdoor installation, in dry and wet locations, on rack trays, in conduits.

INSTRUMENTATION CABLES

RE-2Y(St)YRY PiMF

Screened/armouring multi pair, PE insulated, PVC sheath



ELETTROTEK KABEL® RE-2Y(St)YRY PiMF

ELETTROTEK KABEL® RE-2Y(St)YRY PiMF

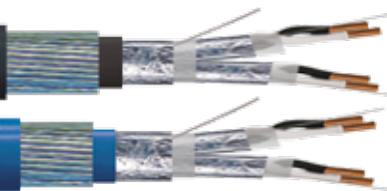

Part no.	No. of pairs x cross section n x mm ²	Outer-Ø ca.mm ± 10%	Copper weight kg/km	Cable weight approx. kg/km	AWG no.*)
47130D.X022M05	2x2x0,50	13,1	33,6	340	20
47130D.X042M05	4x2x0,50	15,3	57,6	475	20
47130D.X082M05	8x2x0,50	20,1	120	735	20
47130D.X122M05	12x2x0,50	23,5	161	1075	20
47130D.X162M05	16x2x0,50	26,4	212	1300	20
47130D.X242M05	24x2x0,50	31,8	313	1730	20
47130D.X022M07	2x2x0,75	13,8	43,2	370	19
47130D.X042M07	4x2x0,75	16,6	81,6	545	19
47130D.X082M07	8x2x0,75	21,1	158,4	820	19
47130D.X122M07	12x2x0,75	25,8	230,4	1260	19
47130D.X162M07	16x2x0,75	27,8	312	1460	19
47130D.X242M07	24x2x0,75	36,0	465,6	2600	19
47130D.X022M10	2x2x1	15,3	52,8	455	18
47130D.X042M10	4x2x1	18	100,8	630	18
47130D.X082M10	8x2x1	23	196,8	1065	18
47130D.X122M10	12x2x1	27,4	292,8	1405	18
47130D.X162M10	16x2x1	30,3	388,8	1680	18
47130D.X242M10	24x2x1	38,8	580,8	2950	18
47130D.X022M15	2x2x1,5	18	72	525	18
47130D.X042M15	4x2x1,5	20,8	134,4	780	16
47130D.X082M15	8x2x1,5	27,2	273,6	1385	16
47130D.X122M15	12x2x1,5	32,2	408	1815	16
47130D.X162M15	16x2x1,5	37,3	527,2	2790	16
47130D.X242M15	24x2x1,5	45,5	763,2	3270	16

* The point inside the part number refers to the different colors in which outer sheath can be produced. Each color has different letter.

Other dimensions and colours available on request.

RE-2Y(St)YRY

Screened/armouring single and multi pair, PE insulated, PVC sheath, 300 V



Construction:

Conductor:	stranded red copper conductor Cl. 2, acc to IEC 60228, DIN VDE 0295
Insulation:	PE compound
Colour cores:	white-black, with black progressively numbered
Stranding:	conductors twisted in pairs
Wrapping:	Polyester tape
Screen:	electrostatic screen of plastic and aluminium tape + tinned drain-wire
Inner sheath:	PVC compound
Armour:	galvanized steel wires
Outer sheath:	black (RAL 9005), or blue (RAL 5015) special PVC compound

Technical data:

Nominal voltage:	300 V
Test voltage:	2 kV
Temperature range:	- 30 °C / + 70 °C
Min. bending radius:	10 x d

Resistance:



Flame retardant and self-extinguishing acc.to:
IEC 60332-1

Features:

fl: on request

standard TS/DIN EN 50288-7

Insulation thickness:	mm	0,50	0,75	1	1,3	1,5
	mm	0,40	0,40	0,40	0,45	0,45

Conductor resistance:	mm	0,50	0,75	1	1,3	1,5
	Ohm/km	36,7	25	18,5	14,2	12,3

Insulation resistance: min. 5 GOhm x km

Mutual capacitance:	≤ 4 pairs	all other pairs				
	0,50 mm ² :	max. 115 pF/m	max. 90 pF/m			
	0,75 mm ² :	max. 115 pF/m	max. 90 pF/m			
	1,0 mm ² :	max. 115 pF/m	max. 90 pF/m			
	1,3 mm ² :	max. 120 pF/m	max. 105 pF/m			

Capacitance unbalance: (1 kHz): max. 500 pF/500 m

L/R (oran-ratio) (max.):	mm ²	0,50	0,75	1,0	1,3	1,5
	mm ²	25	25	25	40	40

Applications:

These cables are used for transmission of analogue and digital signals in instrument and control systems at chemistry and petrochemistry industry plants, natural gas and petroleum plants. With blue sheath it is suitable for intrinsically safe systems. these cables are for indoor/outdoor installation, in dry and wet locations, on rack trays, in conduits.

INSTRUMENTATION CABLES

RE-2Y(St)YRY

Screened/armouring single and multi pair, PE insulated, PVC sheath, 300 V



Part no.	No. of pairs x cross section n x mm ²	Outer-Ø ca.mm ± 10%	Copper weight kg/km	Cable weight approx. kg/km	AWG no.)*
47140C.X012M05	1x2x0,50	10,2	14	185	20
47140C.X022M05	2x2x0,50	12,7	24	265	20
47140C.X042M05	4x2x0,50	14	43	325	20
47140C.X052M05	5x2x0,50	14,5	53	350	20
47140C.X062M05	6x2x0,50	15,4	62	390	20
47140C.X082M05	8x2x0,50	16,6	82	450	20
47140C.X102M05	10x2x0,50	17,7	101	505	20
47140C.X122M05	12x2x0,50	18,7	120	560	20
47140C.X162M05	16x2x0,50	21,4	158	775	20
47140C.X202M05	20x2x0,50	23,2	197	890	20
47140C.X242M05	24x2x0,50	24,6	235	990	19
47140C.X012M07	1x2x0,75	10,6	19	200	19
47140C.X022M07	2x2x0,75	13,4	34	295	19
47140C.X042M07	4x2x0,75	14,8	62	370	19
47140C.X072M07	5x2x0,75	15,5	77	405	19
47140C.X062M07	6x2x0,75	16,3	91	445	19
47140C.X082M07	8x2x0,75	17,7	120	520	19
47140C.X102M07	10x2x0,75	19	149	595	19
47140C.X122M07	12x2x0,75	21	178	770	19
47140C.X162M07	16x2x0,75	23,2	235	920	19
47140C.X202M07	20x2x0,75	25	293	1055	19
47140C.X242M07	24x2x0,75	26,7	350	1195	19
47140C.X012M10	1x2x1	11	24	215	18
47140C.X022M10	2x2x1	14,1	43	325	18
47140C.X042M10	4x2x1	15,9	82	420	18
47140C.X052M10	5x2x1	16,4	101	455	18
47140C.X062M10	6x2x1	17,3	120	505	18
47140C.X082M10	8x2x1	18,8	158	595	18
47140C.X102M10	10x2x1	21,1	197	795	18
47140C.X122M10	12x2x1	22,4	235	880	18
47140C.X162M10	16x2x1	24,8	312	1060	18
47140C.X202M10	20x2x1	26,9	389	1235	18
47140C.X242M10	24x2x1	28,7	466	1390	18
47140C.X012M13	1x2x1.3	11,8	30	245	17
47140C.X022M13	2x2x1.3	15,1	55	365	17
47140C.X042M13	4x2x1.3	17,1	105	480	17
47140C.X052M13	5x2x1.3	17,7	130	530	17
47140C.X062M13	6x2x1.3	18,7	155	585	17
47140C.X082M13	8x2x1.3	21,4	204	810	17
47140C.X102M13	10x2x1.3	23	254	925	17
47140C.X122M13	12x2x1.3	24,6	304	1045	17
47140C.X162M13	16x2x1.3	27,3	404	1270	17
47140C.X202M13	20x2x1.3	29,5	504	1470	17
47140C.X242M13	24x2x1.3	32,8	604	1885	17
47140C.X012M15	1x2x1,5	12,0	34	255	16
47140C.X022M15	2x2x1,5	15,6	62	390	16
47140C.X042M15	4x2x1,5	17,5	120	510	16
47140C.X052M15	5x2x1,5	18,2	149	560	16
47140C.X062M15	6x2x1,5	20,1	178	730	16
47140C.X082M15	8x2x1,5	22	235	865	16
47140C.X102M15	10x2x1,5	23,8	293	1000	16
47140C.X122M15	12x2x1,5	25,3	350	1120	16
47140C.X162M15	16x2x1,5	28,1	466	1365	16
47140C.X202M15	20x2x1,5	30,6	581	1595	16
47140C.X242M15	24x2x1,5	33,8	696	2020	16

* The point inside the part number refers to the different colors in which outer sheath can be produced. Each color has different letter.

Other dimensions and colours available on request.

RE-2X(St)Y-fl

Screened single and multi pair, XLPE insulated, PVC sheath



ELETTROTEK KABEL® RE-2X(Si)Y FI

ELETTROTEK KABEL® RE-2X(Si)Y FI



Construction:

Conductor:	stranded red copper conductor Cl. 2, acc to IEC 60228, DIN VDE 0295
Insulation:	XLPE compound
Colour cores:	white-black, with black progressively numbered
Stranding:	conductors twisted in pairs
Wrapping:	Polyester tape
Screen	electrostatic screen of plastic and aluminium tape + tinned drain-wire
Outer sheath:	black (RAL 9005), or blue (RAL 5015) PVC type YM1

Technical data:

Nominal voltage:	300 V
Test voltage:	1,5 kV
Temperature range	
<i>Fixed laying:</i>	- 30 °C / + 70 °C
<i>Flexible application:</i>	- 5 °C / + 50 °C
Min. bending radius:	7,5 x d

Resistance:



Flame retardant and self-extinguishing acc.to:
PVC DIN VDE 0482 part 266-2-4
EN 50266-2-4
IEC 60332-3-24

Features:

Insulation thickness:	mm	0,50	0,75	1	1,3	1,5
	mm	0,40	0,40	0,40	0,45	0,45
Conductor resistance:	mm	0,50	0,75	1	1,3	1,5
	Ohm/km	36,7	25	18,5	14,2	12,3
Insulation resistance:	min. 5 GOhm x km					
Mutual capacitance:	max. 120 pF/m					
Capacitance unbalance:	(1 kHz): max. 500 pF/500 m					
L/R (oran-ratio) (max.):	mm ²	0,50	0,75	1,0	1,3	1,5
	mm ²	25	25	25	40	40

Applications:

These cables are used for transmission of analogue and digital signals in instrument and control systems at chemistry and petrochemistry industry plants, natural gas and petroleum plants. With blue sheath it is suitable for intrinsically safe systems. these cables are for indoor/outdoor installation, in dry and wet locations, on rack trays, in conduits.

INSTRUMENTATION CABLES

RE-2X(St)Y-fl

Screened single and multi pair, XLPE insulated, PVC sheath



Part no.	No. of pairs x cross section n x mm ²	Outer-Ø ca.mm ± 10%	Copper weight kg/km	Cable weight approx. kg/km	AWG no.®)
47150C.X012M05	1x2x0,50	6,3	15	38	20
47150C.X022M05	2x2x0,50	8,3	24	63	20
47150C.X042M05	4x2x0,50	9	44	98	20
47150C.X082M05	8x2x0,50	11,5	84	160	20
47150C.X122M05	12x2x0,50	13,7	123	235	20
47150C.X162M05	16x2x0,50	15,4	163	291	20
47150C.X242M05	24x2x0,50	18,5	242	414	20
47150C.X012M07	1x2x0,75	6,7	17	49	19
47150C.X022M07	2x2x0,75	9,2	34	87	19
47150C.X042M07	4x2x0,75	10	64	123	19
47150C.X082M07	8x2x0,75	12,8	124	215	19
47150C.X122M07	12x2x0,75	15,3	184	299	19
47150C.X162M07	16x2x0,75	17,5	244	401	19
47150C.X242M07	24x2x0,75	21	364	563	19
47150C.X012M10	1x2x1	7,2	23	54	18
47150C.X022M10	2x2x1	10	45	98	18
47150C.X042M10	4x2x1	11	86	151	18
47150C.X082M10	8x2x1	14,2	167	266	18
47150C.X122M10	12x2x1	17	248	385	18
47150C.X162M10	16x2x1	19,5	330	503	18
47150C.X242M10	24x2x1	23,3	493	740	18
47150C.X012M13	1x2x1,3	7,7	34	65	17
47150C.X022M13	2x2x1,3	11	60	119	17
47150C.X042M13	4x2x1,3	12,2	114	185	17
47150C.X082M13	8x2x1,3	15,7	218	331	17
47150C.X122M13	12x2x1,3	19,1	322	489	17
47150C.X162M13	16x2x1,3	21,8	426	641	17
47150C.X242M13	24x2x1,3	26,2	684	920	17

* The point inside the part number refers to the different colors in which outer sheath can be produced. Each color has different letter.

Other dimensions and colours available on request.

RE-2X(St)Yv PiMF



Construction:

Conductor:	stranded red copper conductor Cl. 2, acc to IEC 60228, DIN VDE 0295
Insulation:	XLPE compound
Colour cores:	white-black, with black progressively numbered
Stranding:	pairs stranded to layers, multi-pair versions with communication core (XLPE-orange)
Wrapping:	Polyester tape
Screen	
<i>Individual:</i>	electrostatic screen of plastic and aluminium tape + tinned drain-wire
<i>Overall:</i>	electrostatic screen of plastic and aluminium tape + tinned drain-wire
Outer sheath:	black (RAL 9005), or blue (RAL 5015) special PVC compound

Technical data:

Nominal voltage:	300 V
Test voltage:	1,5 kV
Temperature range	
<i>Fixed laying:</i>	- 30 °C / + 70 °C
<i>Flexible application:</i>	- 5 °C / + 50 °C
Min. bending radius:	7,5 x d

Resistance:



Flame retardant and self-extinguishing acc.to:
IEC 60332-1

Features:

- fl: on request
- Reinforced outer sheath
- more steady at higher frequencies and temperature by XLPE core insulation (cross-linked PE)
- three-coat shield
- high cross-talk and low cable attenuation
- largely resistant to acids, bases and usual oils
- robust version (generally with strengthened black or blue outer sheath)
- IEC 189 and IEC 502, HD 34, KEMA k102 and draft CENELEC specifications for computer cables
- Conductor resistance:** 0,5 : . max. 39,2 Ohm/km
0,75 : max. 24,6 Ohm/km
1,3 : 14,2 Ohm/km
- Insulation resistance:** min. 5 GOhm x km
- Inductance:** max. 0,65 mH/km

Applications:

computer cable for optimal data transmission at medium data transfer rates up to 200 kbits/s in process control and IT-systems for lossless data and signal transmission. Suitable for dry and humid rooms, outdoor use and laying underground.

INSTRUMENTATION CABLES

RE-2X(St)Yv PiMF



BLACK:

Part no.	No. of pairs x cross section n x mm ²	Outer-Ø ca.mm ± 10%	Copper weight kg/km	Cable weight approx. kg/km	AWG no.*)
47160C7X022M05	2x2x0,5	10,7	35	120	20
47160C7X042M05	4x2x0,5	12,1	62	160	20
47160C7X122M05	12x2x0,5	17,4	176	340	20
47160C7X242M05	24x2x0,5	23	348	580	20
47160C7X022M07	2x2x0,75	11,4	47	140	19
47160C7X042M07	4x2x0,75	13	82	190	19
47160C7X062M07	6x2x0,75	15,2	124	260	19
47160C7X082M07	8x2x0,75	16,1	160	310	19
47160C7X122M07	12x2x0,75	18,8	237	410	19
47160C7X242M07	24x2x0,75	25,5	470	760	19
47160C7X022M13	2x2x1,3	12,6	68	135	16
47160C7X042M13	4x2x1,3	14,4	124	220	16
47160C7X062M13	6x2x1,3	17	181	301	16
47160C7X082M13	8x2x1,3	18	239	389	16
47160C7X122M13	12x2x1,3	21,3	353	580	16
47160C7X242M13	24x2x1,3	29	697	1090	16

BLUE:

Part no.	No. of pairs x cross section n x mm ²	Outer-Ø ca.mm ± 10%	Copper weight kg/km	Cable weight approx. kg/km	AWG no.*)
47160CBX022M05	2x2x0,5	10,7	35	120	20
47160CBX042M05	4x2x0,5	12,1	62	160	20
47160CBX062M05	6x2x0,5	14,1	90	210	20
47160CBX122M05	12x2x0,5	17,4	176	340	20
47160CBX242M05	24x2x0,5	23	348	580	20
47160CBX022M07	2x2x0,75	11,4	47	140	19
47160CBX042M07	4x2x0,75	13	82	190	19
47160CBX062M07	6x2x0,75	15,2	124	260	19
47160CBX082M07	8x2x0,75	16,1	160	310	19
47160CBX122M07	12x2x0,75	18,8	237	410	19
47160CBX242M07	24x2x0,75	25,5	470	760	19
47160CBX022M13	2x2x1,3	12,6	68	135	16
47160CBX042M13	4x2x1,3	14,4	124	220	16
47160CBX062M13	6x2x1,3	17	181	301	16
47160CBX082M13	8x2x1,3	18	239	389	16
47160CBX122M13	12x2x1,3	21,3	353	580	16
47160CBX242M13	24x2x1,3	29	697	1090	16

Other dimensions and colours available on request.

INSTRUMENTATION CABLES

RE-2X(St)YRY



Construction:

Conductor:	stranded red copper conductor Cl. 2, acc to IEC 60228, DIN VDE 029
Insulation:	XLPE compound
Colour cores:	white-black, with black progressively numbered
Stranding:	conductors twisted in pairs
Wrapping:	Polyester tape
Screen:	electrostatic screen of plastic and aluminium tape + tinned drain-wire
Inner sheath:	PVC compound
Armour:	galvanized steel wires
Outer sheath:	black (RAL 9005), or blue (RAL 5015) special PVC compound

Technical data:

Nominal voltage:	300/500 V
Test voltage:	2 kV
Temperature range	- 30 °C / + 90 °C
Min. bending radius:	10 x d

Resistance:



Flame retardant and self-extinguishing acc.to:
IEC 60332-1

Features:

fl: on request

standard TS/DIN EN 50288-7

Insulation thickness:	mm	0,50	0,75	1	1,3	1,5
	mm	0,40	0,40	0,40	0,45	0,45

Conductor resistance:	mm	0,50	0,75	1	1,3	1,5
	Ohm/km	36,7	25	18,5	14,2	12,3

Insulation resistance: min. 5 GOhm x km

Mutual capacitance:	≤ 4 pairs	all other pairs
	0,50 mm ² : max. 115 pF/m	max. 90 pF/m
	0,75 mm ² : max. 115 pF/m	max. 90 pF/m
	1,0 mm ² : max. 115 pF/m	max. 90 pF/m
	1,3 mm ² : max. 120 pF/m	max. 105 pF/m
	1,5 mm ² : max. 120 pF/m	max. 105 pF/m

Capacitance unbalance: (1 kHz): max. 500 pF/500 m

L/R (oran-ratio) (max.):	mm ²	0,50	0,75	1,0	1,3	1,5
	mm ²	25	25	25	40	40

Applications:

These cables are used for transmission of analogue and digital signals in instrument and control systems at chemistry and petrochemistry industry plants, natural gas and petroleum plants. With blue sheath it is suitable for intrinsically safe systems.

these cables are for indoor/outdoor installation, in dry and wet locations, on rack trays, in conduits.

INSTRUMENTATION CABLES

RE-2X(St)YRY



Part no.	No. of pairs x cross section n x mm ²	Outer-Ø ca.mm ± 10%	Copper weight kg/km	Cable weight approx. kg/km	AWG no.*)
47170D.X012M05	1x2x0,50	10,2	14	185	20
47170D.X022M05	2x2x0,50	12,7	24	265	20
47170D.X042M05	4x2x0,50	14	43	325	20
47170D.X052M05	5x2x0,50	14,5	53	350	20
47170D.X062M05	6x2x0,50	15,4	62	390	20
47170D.X082M05	8x2x0,50	16,6	82	450	20
47170D.X102M05	10x2x0,50	17,7	101	505	20
47170D.X122M05	12x2x0,50	18,7	120	560	20
47170D.X162M05	16x2x0,50	21,4	158	775	20
47170D.X202M05	20x2x0,50	23,2	197	890	20
47170D.X242M05	24x2x0,50	24,6	235	990	19
47170D.DBX012M07	1x2x0,75	10,6	19	200	19
47170D.X022M07	2x2x0,75	13,4	34	295	19
47170D.X042M07	4x2x0,75	14,8	62	370	19
47170D.X052M07	5x2x0,75	15,5	77	405	19
47170D.X062M07	6x2x0,75	16,3	91	445	19
47170D.X082M07	8x2x0,75	17,7	120	520	19
47170D.X102M07	10x2x0,75	19	149	595	19
47170D.X122M07	12x2x0,75	21	178	770	19
47170D.X162M07	16x2x0,75	23,2	235	920	19
47170D.X202M07	20x2x0,75	25	293	1055	19
47170D.X242M07	24x2x0,75	26,7	350	1195	19
47170D.X012M10	1x2x1	11	24	215	18
47170D.X022M10	2x2x1	14,1	43	325	18
47170D.X042M10	4x2x1	15,9	82	420	18
47170D.X102M10	5x2x1	16,4	101	455	18
47170D.X062M10	6x2x1	17,3	120	505	18
47170D.X082M10	8x2x1	18,8	158	595	18
47170D.X102M10	10x2x1	21,1	197	795	18
47170D.X122M10	12x2x1	22,4	235	880	18
47170D.X162M10	16x2x1	24,8	312	1060	18
47170D.X202M10	20x2x1	26,9	389	1235	18
47170D.X242M10	24x2x1	28,7	466	1390	18
47170D.X012M13	1x2x1,3	11,8	30	245	17
47170D.X022M13	2x2x1,3	15,1	55	365	17
47170D.X042M13	4x2x1,3	17,1	105	480	17
47170D.X052M13	5x2x1,3	17,7	130	530	17
47170D.X062M13	6x2x1,3	18,7	155	585	17
47170D.X082M13	8x2x1,3	21,4	204	810	17
47170D.X102M13	10x2x1,3	23	254	925	17
47170D.X122M13	12x2x1,3	24,6	304	1045	17
47170D.X162M13	16x2x1,3	27,3	404	1270	17
47170D.X202M13	20x2x1,3	29,5	504	1470	17
47170D.X242M13	24x2x1,3	32,8	604	1885	17
47170D.X012M15	1x2x1,5	12	34	255	16
47170D.X022M15	2x2x1,5	15,6	62	390	16
47170D.X042M15	4x2x1,5	17,5	120	510	16
47170D.X052M15	5x2x1,5	18,2	149	560	16
47170D.X062M15	6x2x1,5	20,1	178	730	16
47170D.X082M15	8x2x1,5	22	235	865	16
47170D.X102M15	10x2x1,5	23,8	293	1000	16
47170D.X122M15	12x2x1,5	25,3	350	1120	16
47170D.X162M15	16x2x1,5	28,1	466	1365	16
47170D.X202M15	20x2x1,5	30,6	581	1595	16
47170D.X242M15	24x2x1,5	33,8	696	2020	16

* The point inside the part number refers to the different colors in which outer sheath can be produced. Each color has different letter.

Other dimensions and colours available on request.

INSTRUMENTATION CABLES

RE4XOHMI (XLPE/CAM/LS0H)



Construction:

Conductor:	stranded red copper conductor Cl. 2, acc to IEC 60228, DIN VDE 0295
Insulation:	XLPE compound
Colour cores:	blue, black with progressively numbered
Stranding:	conductors twisted in pairs
Wrapping:	Polyester tape
Screen:	electrostatic screen of plastic and aluminium tape + tinned drain-wire
Outer sheath:	black (RAL 9005), or blue (RAL 5015) Halogen free compound

Resistance:



Flame retardant acc. to:
DIN VDE 0482 part 265-2-1
EN 50265-2-1
IEC 60332-1
EN 60332-1-2
IEC 60332-3-24



Halogen free acc. to:
EN 50267-2-1
IEC 60754-1
DIN VDE 0482 part.267-2



Low smoke emission acc to:
EN 50268-2 IEC 61034

Technical data:

Nominal voltage:	300/500 V
Test voltage:	2 kV
Temperature range:	- 20 °C / + 90 °C
Min. bending radius:	5 x d

Features:

according to BS 5308-1

Part no.	No. of pairs x cross section n x mm ²	Outer-Ø ca.mm ± 10%	Copper weight kg/km	Cable weight approx. kg/km	AWG no.®)
47180D.X022M05	2x2x0,50	10	24	64	20
47180D.X022M07	2x2x0,75	10,6	33,6	86	19
47180D.X022M10	2x2x1	11,3	43,2	110	18
47180D.X022M15	2x2x1,5	13,3	62,4	130	16
47180D.X102M15	10x2x1,5	26,5	292,8	630	16
47180D.X202M15	20x2x1,5	34,4	580,8	1100	16

* The point inside the part number refers to the different colors in which outer sheath can be produced. Each color has different letter.

Other dimensions and colours available on request.

INSTRUMENTATION CABLES

RE4XHOHMI (XLPE/IAM/CAM/LS0H)



Construction:

- Conductor:** up to 0,75 mm²:
Flexible red copper conductor Cl. 5,
acc to IEC 60228
from 1 mm²:
stranded red copper conductor Cl. 2,
acc to IEC 60228, DIN VDE 0295
- Insulation:** XLPE compound
- Colour cores:** blue,black with progressively numbered
- Stranding:** conductors twisted in pairs-triads.
pairs-triads twisted in concentric layers
- Screen**
- Individual:* electrostatic screen of plastic and
aluminium tape + tinned drain-wire
- Overall:* electrostatic screen of plastic and
aluminium tape + tinned drain-wire
- Outer sheath:** black (RAL 9005), or blue (RAL 5015)
Halogen free compound

Resistance:



Flame retardant acc. to:
DIN VDE 0482 part 265-2-1
EN 50265-2-1
IEC 60332-1
IEC 60332-3-24
EN 60332-1-2



Halogen free acc. to:
EN 50267-2-1
IEC 60754-1
DIN VDE 0482 part.267-2



Low smoke emission acc to:
EN 50268-2 IEC 61034

Technical data:

- Nominal voltage:** 300/500 V
- Test voltage:** 2 kV
- Temperature range:** - 20 °C / + 90 °C
- Min. bending radius:** 5 x d

Features:

according to BS 5308-1

Part no.	No. of pairs x cross section n x mm ²	Outer-Ø ca.mm ± 10%	Copper weight kg/km	Cable weight approx. kg/km	AWG no.*)
47190D.X022M05	2x2x0,50	10	33,6	86	20
47190D.X022M07	2x2x0,75	10,6	43,2	130	19
47190D.X022M10	2x2x1	11,3	52,8	190	18
47190D.X022M15	2x2x1,5	13,3	72	190	16

* The point inside the part number refers to the different colors in which outer sheath can be produced. Each color has different letter.

Other dimensions and colours available on request.

INSTRUMENTATION CABLES

RE4XOHEFR (XLPE/CAM/PE/SWA/PVC)



Construction:

- Conductor:** stranded red copper conductor Cl. 2, acc to IEC 60228, DIN VDE 029
- Insulation:** XLPE compound
- Colour cores:** black/ gray
- Stranding:** conductors twisted in pairs
- Screen:** electrostatic screen of plastic and aluminium tape + tinned drain-wire
- Inner sheath:** PE compound
- Armour:** galvanized steel wires
- Outer sheath:** black (RAL 9005), or blue (RAL 5015) PVC compound

Resistance:



Flame retardant acc. to:
DIN VDE 0482 part 266-2-4
EN 50266-2-4
IEC 60332-3-24

Technical data:

- Nominal voltage:** 300/500 V
- Test voltage:** 2 kV
- Temperature range:** - 30 °C / + 70 °C
- Min. bending radius:** 10 x d

Features:

according to BS 5308-1

Part no.	No. of pairs x cross section n x mm ²	Outer-Ø ca.mm ± 10%	Copper weight kg/km	Cable weight approx. kg/km	AWG no.®)
47200D.X022M05	2x2x0,50	12,3	24	290	20
47200D.X042M05	4x2x0,50	13,6	43,2	360	20
47200D.X122M05	12x2x0,50	20,7	120	790	20
47200D.X242M05	24x2x0,50	27,7	235,2	1370	20
47200D.X022M07	2x2x0,75	12,9	33,6	330	19
47200D.X042M07	4x2x0,75	14,3	62,4	400	19
47200D.X122M07	12x2x0,75	23	177,6	1020	19
47200D.X242M07	24x2x0,75	30,5	350,4	1620	19
47200D.X022M10	2x2x1	13,6	43,2	375	18
47200D.X042M10	4x2x1	16,4	81,6	535	18
47200D.X242M10	24x2x1	33	465,6	1900	18
47200D.X022M15	2x2x1,5	16,5	62,4	525	16
47200D.X042M15	4x2x1,5	19,3	120	960	16
47200D.X242M15	24x2x1,5	41,5	696	3270	16

* The point inside the part number refers to the different colors in which outer sheath can be produced. Each color has different letter.

Other dimensions and colours available on request.

INSTRUMENTATION CABLES

RE4XHOHM1FM1 (XLPE/IAM/CAM/LS0H/SWA/LS0H)



ELETTROTEK KABEL® RE4XHOHM1FM1

ELETTROTEK KABEL® RE4XHOHM1FM1



Construction:

Conductor:	stranded red copper conductor Cl. 2, acc. to IEC 60228, DIN VDE 0295
Insulation:	XLPE compound
Colour cores:	PAIR: black, white TRIAD: black, white, red
Stranding:	conductors twisted in pairs-triads. pairs-triads twisted in concentric layers
Screen	
<i>Individual:</i>	electrostatic screen of plastic and aluminium tape + tinned drain-wire
<i>Overall:</i>	electrostatic screen of plastic and aluminium tape + tinned drain-wire
Inner sheath:	halogen free compound
Armour:	galvanized steel wires
Outer sheath:	blue (RAL 5015) or black (RAL 9005) halogen free compound

Resistance:



Flame retardant acc. to:
DIN VDE 0482 part 266-2-4
EN 50266-2-4
IEC 60332-3-24



Halogen free acc. to:
EN 50267-2-1
IEC 60754-1,
DIN VDE 0482 part.267-2



Low smoke emission acc to:
EN 50268-2 IEC 61034

Technical data:

Nominal voltage:	300/500 V
Test voltage:	2 kV
Temperature range:	- 20 °C / + 90 °C
Min. bending radius:	6 x d

Features:

according to BS 5308-1

PAIRS:

Part no.	No. of pairs x cross section n x mm ²	Outer-Ø ca.mm ± 10%	Copper weight kg/km	Cable weight approx. kg/km	AWG no.®)
47210D.X022M05	2x2x0,50	16,7	33,6	450	20
47210D.X022M07	2x2x0,75	17,6	43,2	500	19
47210D.X022M10	2x2x1	17,6	52,8	520	18
47210D.X012M15	1x2x1,5	12,1	43,2	284	16
47210D.X022M15	2x2x1,5	20,4	72	750	16
47210D.X102M15	10x2x1,5	29,2	302,4	1515	16

TRIADS:

Part no.	No. of triples x cross section n x mm ²	Outer-Ø ca.mm ± 10%	Copper weight kg/km	Cable weight approx. kg/km	AWG no.®)
47210D.X033M05	3x3x0,50	17,1	62,4	530	20
47210D.X033M07	3x3x0,75	17,6	84	560	19
47210D.X033M10	3x3x1	17,7	105,6	600	18
47210D.X033M15	3x3x1,5	20	148,8	740	16

* The point inside the part number refers to the different colors in which outer sheath can be produced. Each color has different letter.

Other dimensions and colours available on request.

SECURITY CABLES



J-Y(St)Y Lg

fire warning installation cable



ELETTROTEK KABEL® J-Y(st)Y Lg BRANDMELDE KABEL



Construction:

Conductor:	solid red copper conductor 0,8 mmØ Cl. 1, acc to IEC 60228
Insulation:	PVC type Y11
Colour cores:	DIN VDE 0815
Stranding:	cores twisted in pairs twisted in concentric layers
Screen:	electrostatic screen of plastic and aluminium tape + tinned drain-wire
Outer sheath:	red (RAL3000) with imprint "BRANDMELDE KABEL", PVC type YM1

Resistance:



Flame retardant and self-extinguishing acc.to:
PVC DIN VDE 0482 part 332-1-2
EN 60332-1-2
IEC 60332-1

Technical data:

Nominal voltage:	300 V
Test voltage:	core/core U eff. 800 V core/screen 800 V
Temperature range	
<i>Fixed laying:</i>	- 30 °C / + 70 °C
<i>Flexible application:</i>	- 5 °C / + 50 °C
Loop resistance: at 20°C	0,6 mm-max. 73,2 Ohm/km
Min. bending radius	
to DIN VDE 0891 part 5 during delivery:	7,5 xd
single bending without tension:	2,5 xd
repeated bending without tension:	7,5 xd
Insulation resistance:	min. 100 MOhm×/km
Mutual capacitance: at 800 Hz	max. 100 nF/km
Capacitance unbalances: at 800 Hz	k ₁ max.300 pF/100 m
Line attenuation: at 800 Hz	1,48 dB/KM

Features:

Fire warning installation cable

SECURITY CABLES

J-Y(St)Y Lg

fire warning installation cable



ELETTROTEK KABEL® J-Y(st)Y Lg BRANDMELDE KABEL



Part no.	No. of cores x conductor diameter n x mm	Outer-Ø ca. mm ± 10%	Copper weight kg/km	Cable weight approx. kg/km	AWG no. *)
49010CRW012M08	1x2x0,8	4,5	11	38	19
49010CRW022M08	2x2x0,8	7	21	60	19
49010CRW032M08	3x2x0,8	8,5	31	80	19
49010CRW042M08	4x2x0,8	9	41	100	19
49010CRW052M08	5x2x0,8	9,5	52	120	19
49010CRW062M08	6x2x0,8	11	62	140	19
49010CRW082M08	8x2x0,8	11,5	82	170	19
49010CRW102M08	10x2x0,8	13,2	102	220	19
49010CRW122M08	12x2x0,8	14,2	123	250	19
49010CRW142M08	14x2x0,8	14,6	145	280	19
49010CRW162M08	16x2x0,8	16	164	320	19
49010CRW202M08	20x2x0,8	17	204	380	19
49010CRW242M08	24x2x0,8	19	244	460	19
49010CRW302M08	30x2x0,8	20,8	304	560	19
49010CRW402M08	40x2x0,8	23	405	710	19
49010CRW502M08	50x2x0,8	26	505	900	19
49010CRW602M08	60x2x0,8	28	606	1050	19
49010CRW802M08	80x2x0,8	31,5	807	1400	19
49010CRWAA2M08	100x2x0,8	33	1008	1750	19

Other dimensions and colours available on request.

SECURITY CABLES

J-H(St)H

fire warning installation cable



CE

ELETTROTEK KABEL® J-H(St)H



Construction:

Conductor:	solid red copper conductor 0,8 mmØ Cl. 1, acc to IEC 60228
Insulation:	Halogen-free compound type HI2
Colour cores:	DIN VDE 0815
Stranding:	cores twisted in quads, quads stranded to units
Wrapping:	plastic tape
Screen:	electrostatic screen of plastic and aluminium tape + tinned drain-wire
Outer sheath:	red (RAL3000) with imprint "BRANDMELDE KABLE", Halogen-free compound type HM2

Resistance:



Flame retardant acc. to:
DIN VDE 0482 part 332-3
EN 60332-3
IEC 60332-3



Halogen free acc. to:
EN 50267-2-1 + IEC 60754-1,
DIN VDE 0482 part.267-2-1



Low corrosiveness combustion gases acc.to:
EN 50267-2, IEC 60754-2,
DIN VDE 0482 part.267-2



Smoke density acc. to:
IEC 61034
EN 61034, CEI 20-38

Technical data:

Nominal voltage:	300 V
Test voltage:	800 V
Temperature range	
<i>Fixed laying:</i>	- 30 °C / + 70 °C
<i>Flexible application:</i>	- 5 °C / + 50 °C
Min. bending radius:	7,5 x d
Radiation resistance:	up to 100x10 ⁶ cJ/kg

Features:

Bd fire warning installation cable

Part no.	No.of cores x conductor diameter n x mm	Outer-Ø ca.mm ± 10%	Copper weight kg/km	Cable weight approx. kg/km	AWG no.®)
49020CRW022M08	2x2x0,8	6,8	25	70	19
49020CRW042M08	4x2x0,8	10,5	45	135	19
49020CRW062M08	6x2x0,8	10,9	65	151	19
49020CRW102M08	10x2x0,8	13,1	106	230	19
49020CRW202M08	20x2x0,8	20,4	206	507	19
49020CRW302M08	30x2x0,8	21,5	307	600	19
49020CRW402M08	40x2x0,8	24,5	407	788	19
49020CRW502M08	50x2x0,8	27,1	508	972	19
49020CRW602M08	60x2x0,8	29,4	608	1120	19
49020CRW802M08	80x2x0,8	33,2	809	1475	19
49020CRWAA2M08	100x2x0,8	37,2	1010	1804	19

Other dimensions and colours available on request.

SECURITY CABLES

JE-H(St)H

Bd fire warning cable, FE 180/E 30 to E 90 (red), Halogen-free



CE

ELETTROTEK KABEL® JE-H(St)H



Construction:

Conductor:	solid red copper conductor 0,8 mmØ Cl. 1, acc to IEC 60228
Insulation:	Halogen-free compound type HI1
Colour cores:	DIN VDE 0815
Stranding:	cores twisted in quads, quads stranded to units
Wrapping:	plastic tape
Screen:	electrostatic screen of plastic and aluminium tape + tinned drain-wire
Outer sheath:	red (RAL3000) with imprint "BRANDMELDE KABLE", Halogen-free compound type HM2

Resistance:



Flame retardant acc. to:
DIN VDE 0482 part 332-3
IEC 60332-3



Halogen free acc. to:
EN 50267-2-1
IEC 60754-1
DIN VDE 0482 part.267-2-1



Low corrosiveness combustion gases acc.to:
EN 50267-2
IEC 60754-2
DIN VDE 0482 part.267-2



Smoke density acc. to:
IEC 61034
EN 61034, CEI 20-38

Technical data:

Nominal voltage:	300 V
Test voltage:	800 V
Temperature range	
<i>Fixed laying:</i>	- 30 °C / + 70 °C
<i>Flexible application:</i>	- 5 °C / + 70 °C
Min. bending radius:	6 x d
Radiation resistance:	up to 100x10 ⁶ cJ/kg

Features:

Bd fire warning installation cable

Part no.	No.of cores x conductor diameter n x mm	Outer-Ø ca.mm ± 10%	Copper weight kg/km	Cable weight approx. kg/km	AWG no.*)
49030CRW022M08	2x2x0,8	7,4	25	70	19
49030CRW042M08	4x2x0,8	10,8	45	135	19
49030CRW082M08	8x2x0,8	16,9	65	151	19
49030CRW122M08	12x2x0,8	18,5	106	230	19
49030CRW162M08	16x2x0,8	20	206	507	19
49030CRW202M08	20x2x0,8	22,2	307	600	19
49030CRW322M08	32x2x0,8	29	407	788	19
49030CRW402M08	40x2x0,8	34,2	508	972	19
49030CRW522M08	52x2x0,8	37,3	608	1120	19

Other dimensions and colours available on request.

SECURITY CABLES

JE-H(St)HRH

Bd fire warning cable, FE 180/E 30 to E 90, Halogen-free



CE

ELETTROTEK KABEL® JE-H(St)HRH



Construction:

- Conductor:** solid red copper conductor 0,8 mmØ
Cl. 1, acc to IEC 60228
- Insulation:** Halogen-free compound type HI1 to DIN VDE 0207 part 23 flame retardant (E90 with special foil wrapping over conductor)
- Colour cores:** DIN VDE 0815
- Stranding:** 2 cores twisted to pair and each 4 pairs layed up in bunches, the bunches stranded in layers
- Wrapping:** plastic tape
- Screen:** electrostatic screen of plastic and aluminium tape + tinned drain-wire
- Inner sheath:** flame retardant polyolefin compound to DIN VDE 0207 type HM3
- Armour:** Braid of galvanized steel wires
- Outer sheath:** red (RAL3000) with imprint "BRANDMELDE KABLE, Halogen-free compound type HM2

Resistance:



Flame retardant acc. to:
DIN VDE 0482 part 332-3
IEC 60332-3



Halogen free acc. to:
EN 50267-2-1
IEC 60754-1
DIN VDE 0482 part.267-2-1



Low corrosiveness combustion gases acc.to:
EN 50267-2
IEC 60754-2
DIN VDE 0482 part.267-2



Smoke density acc. to:
IEC 61034
EN 61034, CEI 20-38

Technical data:

- Nominal voltage:** 300 V
- Test voltage:** 800 V
- Min. bending radius:** 6 x d

Features:

- FE 180: insulation integrity for 180 min.
Test to DIN VDE 0472 part.814 IEC 60331
- E 30: functional for 30 min. Test to DIN 4102 part.12
- E 90: functionally for 90 min. Test to DIN 4102 part.12

Part no.	No.of cores x conductor diameter n x mm	Outer-Ø ca.mm ± 10%	Copper weight kg/km	Cable weight approx. kg/km	AWG no.*)
49040CRW022M08	2x2x0,8	10,5	25	150	19
49040CRW042M08	4x2x0,8	14,8	45	275	19
49040CRW082M08	8x2x0,8	21,1	85	545	19
49040CRW122M08	12x2x0,8	22,7	126	602	19
49040CRW162M08	16x2x0,8	25	166	734	19
49040CRW202M08	20x2x0,8	26,9	206	870	19
49040CRW322M08	32x2x0,8	35	326	1360	19
49040CRW402M08	40x2x0,8	41	407	1800	19
49040CRW522M08	52x2x0,8	44	529	2038	19

Other dimensions and colours available on request.

JE-H(St)H Orange

Bd FE 180/E 30 to E 90 (orange),Halogen-free



CE

ELETTROTEK KABEL® JE-H(St)H

Construction:

Conductor:	solid red copper conductor 0,8 mmØ Cl. 1, acc to IEC 60228
Insulation:	Halogen-free compound type HI1 to DIN VDE 0207 part.23 flame retardant (E90 with special foil wrapping over conductor)
Colour cores:	DIN VDE 0815, (with ring colours and ring groups)
Stranding:	cores twisted in pair, 4 pairs to a unit and several units stranded to layers.
Wrapping:	special polyester tape
Screen:	electrostatic screen of plastic and aluminium tape + tinned drain-wire
Outer sheath:	orange (RAL2003),flame retardant to DIN VDE 0207 part 24,Halogen free type HM2

Technical data:

Nominal voltage:	300 V
Test voltage:	800 V
Temperature range	
<i>Fixed laying:</i>	- 30 °C / + 70 °C
<i>Flexible application:</i>	- 5 °C / + 70 °C
Min. bending radius:	6 x d
Radiation resistance:	up to 100x10 ⁶ cJ/kg

Resistance:



Flame retardant acc. to:
DIN VDE 0482 part 332-3
IEC 60332-3



Halogen free acc. to:
EN 50267-2-1
IEC 60754-1
DIN VDE 0482 part.267-2-1



Low corrosiveness combustion gases acc.to:
EN 50267-2
IEC 60754-2
DIN VDE 0482 part.267-2



Smoke density acc. to:
IEC 61034
EN 61034, CEI 20-38

Features:

FE 180: insulation integrity for 180 min.
Test to DIN VDE 0472 part.814 IEC 60331

E 30: functional for 30 min.Test to DIN 4102 part.12

E 90: functionally for 90 min.Test to DIN 4102 part.12

SECURITY CABLES

JE-H(St)H Orange

Bd FE 180/E 30 to E 90 (orange),Halogen-free



CE



Functionally E 30 to E 90

Part no.	No.of cores x conductor diameter n x mm	Outer-Ø ca.mm ± 10%	Copper weight kg/km	Cable weight approx. kg/km	AWG no.*)
49050CGW012M08	1x2x0,8	6	17	57	19
49050CGW022M08	2x2x0,8	7,4	25	74	19
49050CGW042M08	4x2x0,8	10,8	45	127	19
49050CGW082M08	8x2x0,8	16,9	85	300	19
49050CGW122M08	12x2x0,8	18,5	126	336	19
49050CGW162M08	16x2x0,8	20,1	166	426	19
49050CGW202M08	20x2x0,8	22,2	206	529	19
49050CGW322M08	32x2x0,8	29,1	326	859	19
49050CGW402M08	40x2x0,8	34,2	407	1094	19
49050CGW522M08	52x2x0,8	37,3	529	1280	19

Functionally E 30

Part no.	No.of cores x conductor diameter n x mm	Outer-Ø ca.mm ± 10%	Copper weight kg/km	Cable weight approx. kg/km	AWG no.*)
49051CGW012M08	1x2x0,8	6	17	57	19
49051CGW022M08	2x2x0,8	7,5	25	74	19
49051CGW042M08	4x2x0,8	9,3	45	127	19
49051CGW082M08	8x2x0,8	11,4	85	300	19
49051CGW122M08	12x2x0,8	13	126	336	19
49051CGW162M08	16x2x0,8	15,7	166	426	19
49051CGW202M08	20x2x0,8	16,5	206	529	19
49051CGW322M08	32x2x0,8	20,3	326	859	19
49051CGW402M08	40x2x0,8	23,4	407	1094	19
49051CGW522M08	52x2x0,8	25,2	529	1280	19

Other dimensions and colours available on request.

FTGI0(O)MI 0,6/1 kV



Construction:

Conductor:	flexible red copper conductor Cl.5, acc. to IEC 60228
Insulation:	rubber, type G10
Wrapping:	glass/mica tape, wrapped to helix
Outer sheath:	blue (RAL 5012), halogen-free compound type M1

Technical data:

Nominal voltage:	0,6/1 kV
Test voltage:	4 kV
Temperature range	
<i>Fixed laying:</i>	- 25 °C / + 90 °C
<i>Flexible application:</i>	0 °C / + 90 °C
Max short circuit temperature:	+ 250 °C
Min. bending radius:	12 x d

Resistance:



Flame retardant and self extinguishing acc. to:
EN 50266
IEC 60332-3-24, CEI 20-22III



Halogen free acc. to:
EN 50267-2-1
IEC 60754-1
DIN VDE 0482 part.267-2-1



Fire resistant acc. to:
IEC 60331, EN 50200



Smoke density acc. to:
IEC 61034
EN 61034, CEI 20-38

SECURITY CABLES

FTGI0(O)MI 0,6/I kV



ELETTROTEK KABEL® FTGI00M1

Part no.	No. of cores x cross section n x mm ²	Outer-Ø ca. mm ± 10%	Copper weight kg/km	Cable weight approx. kg/km	AWG no. *)
49060GBL010M15	1x1,5	7,2	14,4	65	16
49060GBL010M25	1x2,5	7,8	24	80	14
49060GBL010M40	1x4	8,2	38,4	100	12
49060GBL010M60	1x6	9	57,6	125	10
49060GBL010M61	1x10	10,6	96	175	8
49060GBL010M62	1x16	11,8	153,6	230	6
49060GBL010M63	1x25	12,9	240	340	4
49060GBL010M64	1x35	15,7	336	460	2
49060GBL010M65	1x50	16,5	480	620	1
49060GBL010M66	1x70	19,5	672	845	2/0
49060GBL010M67	1x95	21	912	1110	3/0
49060GBL010M68	1x120	23	1152	1380	4/0
49060GBL010M69	1x150	25,1	1440	1680	250 MCM
49060GBL010M70	1x185	27,1	1776	2000	350 MCM
49060GBL010M71	1x240	32,1	2304	2580	450 MCM
49060GBL010M72	1x300	34,6	2880	3000	550 MCM
49060GB3020M15	2x1,5	12,7	28,8	170	16
49060GB3020M25	2x2,5	14,1	48	205	14
49060GB3020M40	2x4	14,9	76,8	255	12
49060GB3020M60	2x6	16,1	115,2	330	10
49060GB3020M61	2x10	18,4	192	470	8
49060GB3020M62	2x16	20	307,2	645	6
49060GB3020M63	2x25	23	480	955	4
49060GB3020M64	2x35	25	672	1240	2
49060GB3030M15	3x1,5	13,4	43,2	190	16
49060GB3030M25	3x2,5	14,3	72	235	14
49060GB3030M40	3x4	15,6	115,2	310	12
49060GB3030M60	3x6	17	172,8	395	10
49060GB3030M61	3x10	20	288	575	8
49060GB3030M62	3x16	21,8	460,8	800	6
49060GB3030M63	3x25	25,2	720	1180	4
49060GB3030M64	3x35	28,1	1008	1690	2
49060GB3040M15	4x1,5	14	57,6	225	16
49060GB3040M25	4x2,5	16,2	96	290	14
49060GB3040M40	4x4	17,1	153,6	375	12
49060GB3040M60	4x6	18,1	230,4	490	10
49060GB3040M61	4x10	21,4	384	715	8
49060GB3040M62	4x16	25,2	614,4	975	6
49060GB3040M63	4x25	29,1	960	1450	4
49060GB3035M64	3x35+25	30,2	1248	1910	2
49060GB3050M15	5x1,5	16,1	72	270	16
49060GB3050M25	5x2,5	17,4	120	335	14
49060GB3050M40	5x4	18,2	192	455	12
49060GB3050M60	5x6	19,9	288	580	10
49060GB3050M61	5x10	24,1	480	850	8
49060GB3050M62	5x16	28,3	768	1180	6
49060GB3050M63	5x25	32,2	1200	1735	4
49060GB3050M64	5x35	36,4	1680	2320	2
49060GB1070M15	7x1,5	17,5	100,8	365	16
49060GB1100M15	10x1,5	19,8	144	470	16
49060GB1120M15	12x1,5	21,9	172,8	560	16
49060GB1160M15	16x1,5	24,3	230,4	660	16
49060GB1190M15	19x1,5	27,5	273,6	790	16
49060GB1240M15	24x1,5	29,8	345,6	1020	16
49060GB1072M25	7x2,5	18,3	168	425	14
49060GB1100M25	10x2,5	21,5	240	590	14
49060GB1120M25	12x2,5	23,8	288	700	14
49060GB1160M25	16x2,5	27,5	384	850	14
49060GB1190M25	19x2,5	28,9	456	990	14
49060GB1240M25	24x2,5	33,2	576	1300	14

Other dimensions and colours available on request.

GAALFIRE 90 0,6/1 kV



ELETTROTEK KABEL® GAALFIRE 90 06/1 kv

Construction:

Conductor:	flexible red copper conductor Cl.5, acc. to IEC 60228
Insulation:	rubber, type G10
Wrapping:	glass/mica tape, wrapped to helix
Stranding:	wires twisted together in concentric layers, wrapping overlapped polyester tape
Screen:	electrostatic screen of plastic and aluminium tape + tinned drain-wire
Outer sheath:	red (RAL 3000), halogen-free compound type M1

Technical data:

Nominal voltage:	0,6/1 kV
Test voltage:	4 kV
Temperature range:	- 40 °C / + 90 °C
Min. bending radius:	12 x d

Resistance:



Flame retardant and self extinguishing acc. to:

IEC 60332-1
DIN VDE 0482 part.266-2-4
EN 50266-2-4
IEC 60332-3-24



Halogen free acc. to:

EN 50267-2-1
IEC 60754-1
DIN VDE 0482 part.267-2-1



low corrosiveness gases and smoke opacity emissions during combustion acc. to:

CEI 20-37, IEC 60754, IEC 61034, CEI 20-38

Features:

Acc. to CEI UNEL 00722-00725

conductor acc. to CEI 20-29, IEC 60228

insulation and sheath acc. to CEI 20-11

compound lead-free acc. to CEI 20-52

insulated cables fire resistant with elastometric compound with nominal voltage $\leq U_0/U$ 0,6/1 kV acc. to CEI 20-45

NoBurn cables with IMQ are marked:

- CEI 20-45 PH 90 (outer diameter up to 20 mm) they are fire-resistant complying with CEI 20-36/4-0 (EN50200) regulation, which requires a minimum working time of the cables during the test, that is the cable has to be exposed to direct fire and mechanic shock for 120 minutes at 842 °C.

NoBurn are also "no flame propagation on the single vertical element" cables, complying with CEI 20-35 (EN and IEC 60332-1) test.

Moreover, the cables are made with special "without halogen" blends complying with CEI and CENELEC regulation, in order to prevent any risk coming from any toxic substance issued during the combustion.

That characteristic is verified by many laboratory tests at IMQ and it limits the issue of corrosive, acid and toxic gas and the formation of murky smoke in the surrounding ambient in case of fire.

NoBurn cables are made complying with CEI 20-45 regulation and they are not included in CEI 20-38 1. However, they have equivalent prescriptions about the test regarding the formation of toxic and corrosive smoke and gas.

Applications:

screened cable for power, signaling and control elastometric isolated compound fire retardant, LSOH, with flexible wires protected by fire resistant barrier suitable for the 'power users' emergency areas with danger of explosion or fire (exits and emergency lighting, Alarm signals, warning of smoke or gases, escalators, pumps, fire protection, fire curtains, etc.).

SECURITY CABLES

GAALFIRE 90 06/I kV



Part no.	No. of cores x cross section n x mm ²	Outer-Ø ca. mm ± 10%	Copper weight kg/km	Cable weight approx. kg/km	AWG no. *)
49070GR3020M10	2x1	7,9	24	67	18
49070GR3030M10	3x1	8,2	33,6	85	18
49070GR3040M10	4x1	9,4	43,2	110	18
49070GR3020M15	2x1,5	8,9	33,6	86	16
49070GR3030M15	3x1,5	9,4	48	113	16
49070GR3040M15	4x1,5	10,5	62,4	141	16
49070GR3020M25	2x2,5	10,4	52,8	120	14
49070GR3030M25	3x2,5	10,9	76,8	158	14
49070GR3040M25	4x2,5	12,4	100,8	205	14
49070GR1071M10	7G1	11,5	72	175	18
49070GR1071M15	7G1,5	12,9	105,6	228	16

Other dimensions and colours available on request.

SECURITY CABLES

N2XH-FE 180/E 30



CE



Construction:

Conductor:	Solid or stranded red copper conductor Cl. 1 or 2, acc. to IEC 60228 DIN VDE 0259
Insulation:	core with double insulation: Flame retardant MICA-tape over conductor Core insulation with cross-linked polyethylene compound type 2XI1 to DIN VDE 0276 PART 604
Colour cores:	acc. to DIN VDE 0293-308, HD 308 S2
Stranding:	cores stranded in layers
Wrapping:	halogen-free filling compound, pressed
Outer sheath:	orange (RAL 2003), thermoplastic halogen-free polyolefine, flame retardant, type HM4 to DIN VDE 0276 part 604

Technical data:

Nominal voltage:	0,6/1 kV
Test voltage:	4 kV
Temperature range:	- 30 °C / + 70 °C
Min. bending radius:	12 x d
Radiation resistance:	up to 200x10 ⁶ cJ/kg

Resistance:



Flame retardant acc. to:
DIN VDE 0482 part 332-3
IEC 60332-3



Halogen free acc. to:
EN 50267-2-1
IEC 60754-1
DIN VDE 0482 part.267-2-1



Low corrosiveness combustion gases acc.to:
EN 50267-2
IEC 60754-2
DIN VDE 0482 part.267-2



Low smoke emission acc. to:
EN 50268-2
IEC 61034-2,
DIN VDE 0482 part. 268-2

Features:

Security cable, 0,6/1 kV, with improved fire characteristics

Insulation integrity under flame propagation to VDE 0472 part 814 IEC 60331

Burning behavior in fire (functionality) of the complete cable system to DIN 4102 part 12 (30 min.)

FE 180: insulation integrity for 180 min.
Test to DIN VDE 0472 part.814 IEC 60331

E 30: functionally for 30 min. Test to DIN 4102 part. 12



re: circular solid conductor



rm: circular stranded conductor



sm: sector-shaped stranded conductor



se: sector-shaped solid conductor

SECURITY CABLES

N2XH-FE 180/E 30



CE



Part no.	No. of cores x cross section n x mm ²	Outer-Ø ca.mm ± 10%	Copper weight kg/km	Cable weight approx. kg/km	AWG no.)*
49080GGL010M40	1x4 re	8	38	155	12
49080GGL010M60	1x6 re	9	58	190	10
49080GGL010M61	1x10 re	10	96	215	8
49080GGL010M62	1x16 re	10,5	154	240	6
49080GGL010M63	1x25 rm	13	240	380	4
49080GGL010M64	1x35 rm	14	336	460	2
49080GGL010M65	1x50 rm	15,5	480	590	1
49080GGL010M66	1x70 rm	17,5	672	820	2/0
49080GGL010M67	1x95 rm	19,5	912	1090	3/0
49080GGL010M68	1x120 rm	21	1152	1350	4/0
49080GGL010M69	1x150 rm	23	1440	1650	250 MCM
49080GGL010M70	1x185 rm	25	1776	2030	350 MCM
49080GGL010M71	1x240 rm	29	2304	2590	450 MCM
49080GG3020M15	2x1,5 re	11,5	29	170	16
49080GG3020M25	2x2,5 re	12	48	190	14
49080GG3020M40	2x4 re	13	77	260	12
49080GG3020M60	2x6 re	14	115	310	10
49080GG3020M61	2x10 re	15,5	192	430	8
49080GG3020M62	2x16 re	17,5	307	600	6
49080GG3020M63	2x25 rm	22	480	930	4
49080GG3031M15	3G1,5 re	12	43	170	16
49080GG3031M25	3G2,5 re	12,5	72	220	14
49080GG3031M40	3G4 re	13,5	115	290	12
49080GG3031M60	3G6 re	14,5	173	370	10
49080GG3031M61	3G10 re	16,5	288	530	8
49080GG3031M62	3G16 re	18,5	461	760	6
49080GG3031M63	3G25 rm	23,5	720	1160	4
49080GG3035M63	3G25/16 rm	22,5	874	1430	4
49080GG3031M64	3G35 rm	26	1080	1560	2
49080GG3035M64	3G35/16 rm	28	1162	1810	2
49080GG3031M65	3G50 rm	29	1440	2030	1
49080GG3035M65	3G50/25 rm	32	1680	2340	1
49080GG3031M66	3G70 rm	34	2016	2890	2/0
49080GG3035M66	3G70/35 rm	35	2352	3190	2/0
49080GG3035M67	3G95/50 rm	40	3216	4350	3/0
49080GG3035M68	3G120/70 rm	45	4128	5550	4/0
49080GG3035M69	3G150/70 rm	48,5	4992	6560	250 MCM
49080GG3035M70	3G185/95 rm	54	6240	8240	350 MCM
49080GG3041M15	4G1,5 re	12,5	58	210	16
49080GG3041M25	4G2,5 re	13	96	260	14
49080GG3041M40	4G4 re	13	154	310	12
49080GG3041M60	4G6 re	14,5	230	410	10
49080GG3041M61	4G10 re	16	384	620	8
49080GG3041M62	4G16 re	18	614	900	6
49080GG3040M63	4X25 re	23,6	960	1600	4
49080GG3040M64	4X35 re	26,4	1344	2050	2
49080GG3040M65	4X50 re	29,5	1920	2761	1
49080GG3040M66	4X70 re	34,6	2688	3785	2/0
49080GG3040M67	4X95 re	39	3648	5010	3/0
49080GG3040M68	4X120 re	43,5	4608	6135	4/0
49080GG3051M15	5G1,5 re	12	72	210	16
49080GG3051M25	5G2,5 re	13	120	280	14
49080GG3051M40	5G4 re	14,5	192	380	12
49080GG3051M60	5G6 re	15,5	288	510	10
49080GG3051M61	5G10 re	18	480	760	8
49080GG3051M62	5G16 re	20	768	1120	6
49080GG3050M63	5x25 re	24,5	1200	1840	4
49080GG3050M64	5x35 re	33,5	1680	2510	2
49080GG1071M15	7G1,5 re	13	101	250	16
49080GG1121M15	12G1,5 re	16,5	173	390	16

Other dimensions and colours available on request.

N2XCH-FE 180/E 30



CE



Construction:

Conductor:	Solid or stranded red copper conductor Cl. 1 or 2, acc. to IEC 60228 DIN VDE 0259
Insulation:	core with double insulation: Flame retardant MICA-tape over conductor Core insulation with cross-linked polyethylene compound type 2X11 to DIN VDE 0276 PART 604
Colour cores:	acc. to DIN VDE 0293-308, HD 308 S2
Stranding:	cores stranded in layers
Wrapping:	halogen-free filling compound, pressed
Screen:	concentric conductor of corrugated copper wires + copper tape
Outer sheath:	orange (RAL 2003), thermoplastic halogen-free polyolefine, flame retardant, type HM4 to DIN VDE 0276 part 604

Technical data:

Nominal voltage:	0,6/1 kV
Test voltage:	4 kV
Temperature range:	- 30 °C / + 70 °C
Min. bending radius:	15 x d
Radiation resistance:	up to 200x10 ⁶ cJ/kg

Resistance:



Flame retardant acc. to:
DIN VDE 0482 part 332-3
IEC 60332-3



Halogen free acc. to:
EN 50267-2-1
IEC 60754-1
DIN VDE 0482 part.267-2-1



Low corrosiveness combustion gases acc. to:
EN 50267-2
IEC 60754-2
DIN VDE 0482 part.267-2



Low smoke emission acc. to:
EN 50268-2
IEC 61034-2
DIN VDE 0482 part. 268-2

Features:

Security cable, 0,6/1 kV, with improved fire characteristics

Insulation integrity under flame propagation to VDE 0472 part 814 IEC 60331

Burning behavior in fire (functionality) of the complete cable system to DIN 4102 part 12 (30 min.)

FE 180: insulation integrity for 180 min. Test to DIN VDE 0472 part.814 IEC 60331

E 30: functionally for 30 min. Test to DIN 4102 part.12

 re: circular solid conductor

 rm: circular stranded conductor

 sm: sector-shaped stranded conductor

 se: sector-shaped solid conductor

SECURITY CABLES

N2XCH-FE 180/E 30



CE



Part no.	No. of cores x cross section n x mm ²	Outer-Ø ca. mm ± 10%	Copper weight kg/km	Cable weight approx. kg/km	AWG no. *)
49090GG3020M15	2x1,5/1,5 re	13	52	200	16
49090GG3020M25	2x2,5/2,5 re	14	80	250	14
49090GG3020M40	2x4/4 re	15	123	310	12
49090GG3020M60	2x6/6 re	16	182	400	10
49090GG3020M61	2x10/10 re	17,5	312	570	8
49090GG3030M15	3x1,5/1,5 re	13	66	220	16
49090GG3030M25	3x2,5/2,5 re	14	104	270	14
49090GG3030M40	3x4/4 re	15,5	161	360	12
49090GG3030M60	3x6/6 re	16,5	24	470	10
49090GG3030M61	3x10/10 re	18,5	408	680	8
49090GG3030M62	3x16/16 re	21	643	960	6
49090GG3030M63	3x25/16 rm	25,5	902	1390	4
49090GG3030M64	3x35/16 rm	29	1190	1720	4
49090GG3030M65	3x50/25 rm	31,5	1723	2320	1
49090GG3030M66	3x70/35 rm	36,5	2410	3260	2/0
49090GG3030M67	3x95/50 rm	40	3296	4310	3/0
49090GG3030M68	3x120/70 rm	46	4236	5520	4/0
49090GG3030M69	3x150/70 rm	50,5	5100	6620	250 MCM
49090GG3030M70	3x185/95 rm	55	6383	8180	350 MCM
49090GG3030M71	3x240/120 rm	61,5	8242	10620	450 MCM
49090GG3040M15	4x1,5/1,5 re	15	81	260	16
49090GG3040M25	4x2,5/2,5 re	16	128	310	14
49090GG3040M40	4x4/4 re	17	200	420	12
49090GG3040M60	4x6/6 re	18	297	540	10
49090GG3040M61	4x10/10 re	20	504	800	8
49090GG3040M62	4x16/16 re	22,5	796	1150	6
49090GG3040M63	4x25/16 re	28	1142	1670	4
49090GG3040M64	4x35/16 re	30,5	1526	2160	2
49090GG3040M65	4x50/25 re	32	2203	2860	1
49090GG3040M66	4x70/35 re	39,5	3082	3980	2/0
49090GG3040M67	4x95/50 re	43,5	4208	5300	3/0
49090GG3040M68	4x120/70 re	49,5	5388	6740	4/0
49090GG3040M69	4x150/70 re	55,5	6558	8210	250 MCM
49090GG3040M70	4x185/95 re	60	8159	10200	350 MCM
49090GG3040M71	4x240/120 re	68	10546	12900	450 MCM
49090GG1070M15	7x1,5/2,5 re	16,5	133	360	16
49090GG1120M15	30x1,5/6 re	29	499	1070	16

Other dimensions and colours available on request.

NHXH-FE 180/E 30



CE

ELETTROTEK KABEL® NHXH-FE 180/E 30

Construction:

Conductor:	Solid or stranded red copper conductor Cl. 1 or 2, acc. to IEC 60228 DIN VDE 0259
Insulation:	double core insulation of mica tape and cross-linked polymer type HI1, to DIN VDE 0207 part 23
Colour cores:	acc. to DIN VDE 0293-308, HD 308 S2
Stranding:	cores stranded in layers
Wrapping:	glass-fibre
Outer sheath:	orange (RAL 2003), polymer compound DIN VDE 0207 part 24, flame retardant

Technical data:

Nominal voltage:	0,6/1 kV
Test voltage:	4 kV
Temperature range:	- 30 °C / + 70 °C
Min. bending radius:	15 x d
Radiation resistance:	up to 200x10 ⁶ cJ/kg

Resistance:



Flame retardant acc. to:
IEC 60332-3-24
EN 50266-2
DIN VDE 0482 part.266-2



Halogen free acc. to:
EN 50267-2-1
IEC 60754-1
DIN VDE 0482 part.267-2-1



Low corrosiveness combustion gases acc.to:
EN 50267-2
IEC 60754-2
DIN VDE 0482 part.267-2



Low smoke emission acc. to:
EN 50268-2
IEC 61034-2
DIN VDE 0482 part. 268-2

Features:

Security cable, 0,6/1 kV, with improved fire characteristics

Insulation integrity under flame
propagation to VDE 0472 part 814 IEC 60331

Burning behavior in fire (functionality)
of the complete cable system to DIN 4102
part 12 (30 min.)

FE 180: insulation integrity for 180 min.
Test to DIN VDE 0472 part.814 IEC 60331

E 30: functionally for 30 min. Test to DIN 4102 part. 12



re: circular solid conductor



rm: circular stranded conductor



sm: sector-shaped stranded conductor



se: sector-shaped solid conductor

SECURITY CABLES

NHXH-FE 180/E 30



CE

ELETTROTEK KABEL® NHXH-FE 180/E 30

Part no.	No. of cores x cross section n x mm ²	Outer-Ø ca.mm ± 10%	Copper weight kg/km	Cable weight approx. kg/km	AWG no.)*
49100GGL010M40	1x4 re	7	38	98	12
49100GGL010M60	1x6 re	7,5	58	125	10
49100GGL010M61	1x10	8	96	165	8
49100GGL010M62	1x16	9	154	230	6
49100GGL010M63	1x25	10,5	240	345	4
49100GGL010M64	1x35	11,5	336	450	2
49100GGL010M65	1x50	12	480	590	1
49100GGL010M66	1x70	15	672	800	2/0
49100GGL010M67	1x95	16,5	912	1100	3/0
49100GGL010M68	1x120	18,5	1152	1350	4/0
49100GGL010M69	1x150	20,5	1440	1650	250 MCM
49100GGL010M70	1x185	23	1776	2000	350 MCM
49100GGL010M71	1x240	25,5	2304	2650	450 MCM
49100GGL010M72	1x300	31,8	2880	3200	550 MCM
49100GG3020M25	2x2,5	12,5	48	290	14
49100GG3020M40	2x4	13,5	77	345	12
49100GG3020M60	2x6	14,5	115	410	10
49100GG3020M61	2x10	16	192	540	8
49100GG3020M62	2x16	18	307	720	6
49100GG3020M63	2x25	21	480	1100	4
49100GG3020M64	2x35	24	672	1120	2
49100GG2031M15	3G1,5	12,5	43	280	16
49100GG2031M25	3G2,5	13,5	72	330	14
49100GG2031M40	3G4	14,5	115	400	12
49100GG2031M60	3G6	15,5	173	480	10
49100GG2031M61	3G10	17	288	650	8
49100GG2031M62	3G16	19	461	850	6
49100GG2031M63	3G25	22,5	720	1300	4
49100GG2031M64	3G35	24,5	1080	1700	2
49100GG2031M65	3G50	27,5	1440	2200	1
49100GG2031M66	3G70 rm	32	2016	3000	2/0
49100GG2031M67	3G95 rm	35,5	2736	4000	3/0
49100GG2031M68	3G120 rm	39,5	3456	4850	4/0
49100GG2031M69	3G150 rm	44	4320	5950	250 MCM
49100GG2031M67	3G185 rm	49,5	5328	7450	350 MCM
49100GG2031M71	3G240 rm	60	6910	8600	450 MCM
49100GG2041M15	4G1,5 re	13,5	58	325	16
49100GG2041M25	4G2,5 re	14	96	385	14
49100GG2041M40	4G4 re	15,5	154	470	12
49100GG2041M60	4G6 re	16,5	230	580	10
49100GG2041M61	4G10 re	18,5	384	790	8
49100GG2041M62	4G16 rm	20,5	614	1100	6
49100GG2041M63	4G25 rm	24,5	960	1650	4
49100GG2041M64	4G35 rm	27	1344	2150	2
49100GG2041M65	4G50 rm	30	1920	2800	1
49100GG2041M66	4G70 rm	35	2688	3800	2/0
49100GG2041M67	4G95 rm	39,5	3648	5050	3/0
49100GG2041M68	4G120 rm	43,5	4608	6150	4/0
49100GG2041M69	4G150 rm	49	5760	7650	250 MCM
49100GG2051M15	5G1,5 re	14	72	375	16
49100GG2051M25	5G2,5 re	15	120	445	14
49100GG2051M40	5G4 re	16,5	192	560	12
49100GG2051M60	5G6 re	18	288	690	10
49100GG2051M61	5G10 re	20	480	950	8
49100GG2051M62	5G16 re	22,5	768	1300	6
49100GG2051M63	5G25 rm	26,5	1200	1980	4
49100GG2051M64	5G35 rm	36	1680	2600	2
49100GG0071M15	7G1,5 re	15	101	365	16
49100GG0071M25	7G2,5 re	16,5	168	540	14
49100GG0101M15	10G1,5 re	18	144	580	16
49100GG0101M25	10G2,5 re	20	240	710	14
49100GG0121M15	12G1,5 re	19	173	640	16
49100GG0121M25	12G2,5 re	20,5	288	790	14

Other dimensions and colours available on request.

SECURITY CABLES

NHXCH-FE 180/E 30



CE

ELETTROTEK KABEL® NHXCH-FE 180/E 30

Construction:

Conductor:	Solid or stranded red copper conductor Cl. 1 or 2, acc. to IEC 60228 DIN VDE 0259
Insulation:	special core insulation of mica tape and cross-linked polymer type HI1, acc. to DIN VDE 0207 part 23
Colour cores:	acc. to DIN VDE 0293-308, HD 308 S2
Stranding:	cores stranded in layers
Wrapping:	glass-fibre
Screen:	red copper wires and one or two copper tape(s) applied helically
Outer sheath:	orange (RAL 2003), polymer compound DIN VDE 0207 part 24, flame retardant

Technical data:

Nominal voltage:	0,6/1 kV
Test voltage:	4 kV
Min. bending radius:	15 x d
Radiation resistance:	up to 200x10 ⁶ cJ/kg

Resistance:



Flame retardant acc. to:
IEC 60332-3
EN 50266-2
DIN VDE 0482 part.266-2



Halogen free acc. to:
EN 50267-2-1
IEC 60754-1
DIN VDE 0482 part.267-2-1



Low corrosiveness combustion gases acc. to:
EN 50267-2,
IEC 60754-2,
DIN VDE 0482 part.267-2



Low smoke emission acc. to:
EN 50268-2
IEC 61034-2
DIN VDE 0482 part. 268-2

Features:

Security cable, 0,6/1 kV, with improved fire characteristics

Insulation integrity under flame
propagation to VDE 0472 part 814 IEC 60331

Burning behavior in fire (functionality)
of the complete cable system to DIN 4102
part 12 (30 min.)

FE 180: insulation integrity for 180 min.
Test to DIN VDE 0472 part.814 IEC 60331

E 30: functionally for 30 min. Test to DIN 4102 part. 12



re: circular solid conductor



rm: circular stranded conductor



sm: sector-shaped stranded conductor



se: sector-shaped solid conductor

SECURITY CABLES

NHXCH-FE 180/E 30



CE

ELETTROTEK KABEL® NHXCH-FE 180/E 30

Part no.	No. of cores x cross section n x mm ²	Outer-Ø ca. mm ± 10%	Copper weight kg/km	Cable weight approx. kg/km	AWG no. *)
49110GG3020M15	2x1,5/1,5 re	15	52	220	16
49110GG3020M25	2x2,5/2,5 re	13,5	80	385	14
49110GG3020M40	2x4/4 re	14,5	123	470	12
49110GG3020M60	2x6/6 re	16	182	550	10
49110GG3020M61	2x10/10 re	18	312	730	8
49110GG3030M15	3x1,5/1,5 re	13,5	66	380	16
49110GG3030M25	3x2,5/2,5 re	14,5	104	430	14
49110GG3030M40	3x4/4 re	15,5	161	530	12
49110GG3030M60	3x6/6 re	16,5	240	630	10
49110GG3030M61	3x10/10 re	18,5	408	850	8
49110GG3030M62	3x16/16 rm	20,5	643	1150	6
49110GG3030M63	3x25/16 rm	24	902	1700	4
49110GG3030M64	3x35/16 rm	26,5	1190	2150	2
49110GG3030M65	3x50/25 rm	29,5	1723	2800	1
49110GG3030M66	3x70/35 rm	33	2410	3800	2/0
49110GG3030M67	3x95/50 rm	37,5	3296	5100	3/0
49110GG3030M68	3x120/70 rm	42,5	4236	6250	4/0
49110GG3030M69	3x150/70 rm	47	5100	6900	250
49110GG3030M70	3x185/95 rm	52,5	6383	8550	350
49110GG3030M71	3x240/120 rm	58,5	8242	11150	450 MCM
49110GG3040M15	4x1,5/1,5 re	14,5	81	435	16
49110GG3040M25	4x2,5/2,5 re	15,5	128	500	14
49110GG3040M40	4x4/4 re	16,5	200	610	12
49110GG3040M60	4x6/6 re	17,5	297	740	10
49110GG3040M61	4x10/10 re	20	504	1050	8
49110GG3040M62	4x16/16 re	22	796	1350	6
49110GG3040M63	4x25/16 rm	26	1142	1950	4
49110GG3040M64	4x35/16 rm	28,5	1526	2400	2
49110GG3040M65	4x50/25 rm	32	2203	3200	1
49110GG3040M66	4x70/35 rm	37	3082	4300	2/0
49110GG3040M67	4x95/50 rm	41,5	4208	5750	3/0
49110GG3040M68	4x120/70 rm	47	5388	7100	4/0
49110GG3040M69	4x150/70 rm	52	6558	8550	250 MCM
49110GG3040M70	4x185/95 rm	58	8159	10700	350 MCM
49110GG3040M71	4x240/120 rm	64	10546	13930	450 MCM
49110GG1070M15	7x1,5/2,5 re	16,5	133	635	16
49110GG1070M25	7x2,5/2,5 re	17,5	200	680	14
49110GG1100M15	10x1,5/2,5 re	19,5	176	870	16
49110GG1100M25	10x2,5/4 re	21	286	980	14
49110GG1120M15	12x1,5/2,5 re	20	205	1050	16
49110GG1120M25	12x2,5/4 re	21,5	334	1050	14
49110GG1240M15	24x1,5/6 re	26	413	1900	16
49110GG1240M25	24x2,5/6 re	28,5	696	1900	14
49110GG1300M15	30x1,5/6 re	27	499	2200	16
49110GG1300M25	30x2,5/10 re	30	840	2200	14

Other dimensions and colours available on request.

SECURITY CABLES

N2XH-FE 180/E 90



CE



Construction:

Conductor:	Solid or stranded red copper conductor Cl. 1 or 2, acc. to IEC 60228 DIN VDE 0259
Insulation:	core insulation with cross-linked polyethylene. type 2X11 to DIN VDE 0276 PART 604. core with double insulation, flame retardant MICA-tapeover conductor.
Colour cores:	acc. to DIN VDE 0293-308, HD 308 S2
Stranding:	cores stranded in layers
Wrapping:	halogen-free filling compound, pressed
Outer sheath:	orange (RAL 2003), thermoplastic halogen-free polyolefine compound, type HM4 to DIN VDE 0276 part 604, flame retardant.

Technical data:

Nominal voltage:	0,6/1 kV
Test voltage:	4 kV
Highest voltage:	Um 1,2 kV
Temperature range:	- 30 °C / + 70 °C
Min. bending radius:	12 x d
Radiation resistance:	up to 200x10 ⁶ cJ/kg

Resistance:



Flame retardant acc. to:
IEC 60332-3
EN 50266-2
DIN VDE 0482 part.266-2



Halogen free acc. to:
EN 50267-2-1
IEC 60754-1
DIN VDE 0482 part.267-2-1



Low corrosiveness combustion gases acc.to:
EN 50267-2,
IEC 60754-2,
DIN VDE 0482 part.267-2



Low smoke emission acc. to:
EN 50268-2
IEC 61034-2
DIN VDE 0482 part. 268-2

Features:

Security cable, 0,6/1 kV, with improved fire characteristics

Insulation integrity under flame
propagation to VDE 0472 part 814 IEC 60331

Burning behavior in fire (functionality)
of the complete cable system to DIN 4102
part 12 (90 min.)

FE 180: insulation integrity for 180 min.
Test to DIN VDE 0472 part.814 IEC 60331

E 90: functionally for 90 min. Test to DIN 4102 part.12



re: circular solid conductor



rm: circular stranded conductor



sm: sector-shaped stranded conductor



se: sector-shaped solid conductor

SECURITY CABLES

N2XH-FE 180/E 90



CE



Part no.	No. of cores x cross section n x mm ²	Outer-Ø ca.mm ± 10%	Copper weight kg/km	Cable weight approx. kg/km	AWG no.)*
49120GGL010M62	1x16 rm	11,5	154	250	6
49120GGL010M63	1x25 rm	13	240	360	4
49120GGL010M64	1x35 rm	14	336	460	2
49120GGL010M65	1x50 rm	15,5	480	610	1
49120GGL010M66	1x70 rm	17,5	672	840	2/0
49120GGL010M67	1x95 rm	19,5	912	1120	3/0
49120GGL010M68	1x120 rm	21,5	1152	1390	4/0
49120GGL010M69	1x150 rm	23,5	1440	1690	250 MCM
49120GGL010M70	1x185 rm	25,5	1776	2090	350 MCM
49120GGL010M71	1x240 rm	28,5	2304	2660	450 MCM
49120GGL010M72	1x300 rm	31	2880	3350	550 MCM
49120GGL010M73	1x400 rm	34,5	3840	4230	650 MCM
49120GG3020M15	2x1,5 re	14,5	29	270	16
49120GG3020M25	2x2,5 re	15,5	48	310	14
49120GG3020M40	2x4 re	16,5	77	370	12
49120GG3020M60	2x6 re	17,5	115	440	10
49120GG3020M61	2x10 rm	19,5	192	600	8
49120GG3020M62	2x16 rm	21	307	780	6
49120GG3020M63	2x25 rm	23,5	480	1100	4
49120GG3020M64	2x35 rm	26,5	672	1400	2
49120GG3020M65	2x50 rm	30	960	1830	1
49120GG3020M66	2x70 rm	33	1344	2420	2/0
49120GG3020M67	2x95 rm	37,5	1824	3240	3/0
49120GG3020M68	2x120 rm	41,0	2304	3940	4/0
49120GG3030M15	3x1,5 re	15	43	260	16
49120GG3030M25	3x2,5 re	16	72	350	14
49120GG3030M40	3x4 re	17	115	420	12
49120GG3030M60	3x6 re	18	173	520	10
49120GG3030M61	3x10 rm	20,5	288	710	8
49120GG3030M62	3x16 rm	22,5	461	950	6
49120GG3030M63	3x25 rm	26	720	1370	4
49120GG3035M64	3x35/16 rm	29,5	1162	1950	2
49120GG3030M64	3x35 rm	28	1008	1750	2
49120GG3035M65	3x50/25 rm	33,5	1680	2640	1
49120GG3030M65	3x50 rm	32	1440	2310	1
49120GG3030M66	3x70 rm	35,5	2016	3100	2/0
49120GG3035M66	3x70/35 rm	37	2352	3520	2/0
49120GG3035M67	3x95/50 rm	42	3216	4710	3/0
49120GG3030M67	3x95 rm	40,5	2736	4180	3/0
49120GG3035M68	3x120/70 rm	46,5	4128	5910	4/0
49120GG3030M68	3x120 rm	44	3456	5130	4/0
49120GG3030M69	3x150 rm	48,5	4320	6260	250 MCM
49120GG3035M69	3x150/70 rm	50	4992	6970	250 MCM
49120GG3035M70	3x185/95 rm	55,5	6240	8750	350 MCM
49120GG3030M70	3x185 rm	53	5328	7720	350 MCM
49120GG3035M71	3x240/120 rm	61,5	8064	1180	450 MCM
49120GG3030M71	3x240 rm	59,5	6912	9990	450 MCM
49120GG3040M15	4x1,5 re	16,5	58	350	16
49120GG3040M25	4x2,5 re	17,5	96	420	14
49120GG3040M40	4x4 re	18,5	154	510	12
49120GG3040M60	4x6 re	19,5	230	630	10
49120GG3040M61	4x10 rm	22,5	384	880	8
49120GG3040M62	4x16 rm	24,5	614	180	6
49120GG3040M63	4x25 rm	28,5	960	1730	4
49120GG3040M64	4x35 rm	31	1344	2220	2
49120GG3040M65	4x50 rm	35	1920	2940	1
49120GG3040M66	4x70 rm	39	2688	3960	2/0
49120GG3040M67	4x95 rm	45	3648	5360	3/0
49120GG3040M68	4x120 rm	48,5	4608	6550	4/0
49120GG3040M69	4x150 rm	54	5760	8070	250 MCM
49120GG3040M70	4x185 rm	59	7104	9970	350 MCM
49120GG3040M71	4x240 rm	66	9216	12830	450 MCM

Other dimensions and colours available on request.

SECURITY CABLES

N2XCH-FE 180/E 90



CE

ELETTROTEK KABEL® N2XCH-FE 180/E 90

Construction:

Conductor:	Solid or stranded red copper conductor Cl. 1 or 2, acc. to IEC 60228 DIN VDE 0259
Insulation:	core insulation with cross-linked polyethylene. type 2X11 to DIN VDE 0276 PART 604. core with double insulation. flame retardant MICA-tapeover conductor.
Colour cores:	acc. to DIN VDE 0293-308, HD 308 S2
Stranding:	cores stranded in layers
Wrapping:	halogen-free filling compound, pressed
Screen:	concentric conductor of corrugated copper wires + copper tape
Outer sheath:	orange (RAL 2003), thermoplastic halogen-free polyolefine, flame retardant, type HM4 to DIN VDE 0276 part 604

Technical data:

Nominal voltage:	0,6/1 kV
Test voltage:	4 kV
Highest voltage:	Um 1,2 kV
Temperature range:	- 30 °C / + 70 °C
Min. bending radius:	12 x d
Radiation resistance:	up to 200x10 ⁶ cJ/kg

Resistance:



Flame retardant acc. to:
IEC 60332-3
EN 50266-2
DIN VDE 0482 part.266-2



Halogen free acc. to:
EN 50267-2-1
IEC 60754-1
DIN VDE 0482 part.267-2-1



Low corrosiveness combustion gases acc. to:
EN 50267-2,
IEC 60754-2,
DIN VDE 0482 part.267-2



Low smoke emission acc. to:
EN 50268-2
IEC 61034-2
DIN VDE 0482 part. 268-2

Features:

Security cable, 0,6/1 kV, with improved fire characteristics

Insulation integrity under flame
propagation to VDE 0472 part 814 IEC 60331

Burning behavior in fire (functionality)
of the complete cable system to DIN 4102
part 12 (90 min.)

FE 180: insulation integrity for 180 min.
Test to DIN VDE 0472 part.814 IEC 60331

E 90: functionally for 90 min. Test to DIN 4102 part. 12



re: circular solid conductor



rm: circular stranded conductor



sm: sector-shaped stranded conductor



se: sector-shaped solid conductor

SECURITY CABLES

N2XCH-FE 180/E 90



CE



Part no.	No. of cores x cross section n x mm ²	Outer-Ø ca. mm ± 10%	Copper weight kg/km	Cable weight approx. kg/km	AWG no. *)
49130GG3030M15	3x1,5/1,5 re	16,5	66	330	16
49130GG3030M25	3x2,5/2,5 re	17,5	104	400	14
49130GG3030M40	3x4/4 re	18,5	161	480	12
49130GG3030M60	3x6/6 re	20	240	600	10
49130GG3030M61	3x10/10 re	22	408	840	8
49130GG3030M62	3x16/16 rm	24,5	643	1130	6
49130GG3030M63	3x25/16 rm	28	902	1560	4
49130GG3030M64	3x35/16 rm	30,5	1190	1960	2
49130GG3030M65	3x50/25 rm	34	1723	2610	1
49130GG3030M66	3x70/35 rm	37,5	2410	3500	2/0
49130GG3030M67	3x95/50 rm	43	3296	4700	3/0
49130GG3030M68	3x120/70 rm	48	4236	5880	4/0
49130GG3030M69	3x150/70 rm	52	4992	7300	250 MCM
49130GG3030M70	3x185/95 rm	57,5	6383	8760	350 MCM
49130GG3030M71	3x240/120 rm	63,5	8242	11280	450 MCM
49130GG3040M15	4x1,5/1,5 re	17,5	81	390	16
49130GG3040M25	4x2,5/2,5 re	19	128	470	14
49130GG3040M40	4x4/4 re	20	200	570	12
49130GG3040M60	4x6/6 re	21,5	297	720	10
49130GG3040M61	4x10/10 rm	24	504	1010	8
49130GG3040M62	4x16/16 rm	26,5	796	1370	6
49130GG3040M63	4x25/16 rm	30,5	1142	1940	4
49130GG3040M64	4x35/16 rm	33	1526	2420	2
49130GG3040M65	4x50/25 rm	37,5	2203	3240	1
49130GG3040M66	4x70/35 rm	41,5	3082	4360	2/0
49130GG3040M67	4x95/50 rm	47,5	4208	5900	3/0
49130GG3040M68	4x120/70 rm	52,5	5388	7340	4/0
49130GG3040M69	4x150/70 rm	57,5	6540	8840	250 MCM
49130GG3040M70	4x185/95 rm	63,5	8159	11020	350 MCM
49130GG3040M71	4x240/120 rm	70	10546	14140	450 MCM
49130GG1070M15	7x1,5/2,5 re	20,5	133	520	16
49130GG1070M25	7x2,5/2,5 re	22	200	630	14
49130GG1120M15	12x1,5/2,5 re	26	205	770	16
49130GG1120M25	12x2,5/2,5 re	28,5	334	950	14
49130GG1240M15	24x1,5/6 re	35	413	1380	16
49130GG1240M25	24x2,5/10 re	37,5	696	1750	14
49130GG1300M15	30x1,5/6 re	37	499	1630	16
49130GG1300M25	30x2,5/10 re	39,5	840	2080	14

Other dimensions and colours available on request.

NHXXH-FE 180/E 90



CE



Construction:

Conductor:	Solid or stranded red copper conductor Cl. 1 or 2, acc. to IEC 60228 DIN VDE 0259
Insulation:	double core insulation of mica tape and cross-linked polymer type HI1, to DIN VDE 0207 part 23
Colour cores:	acc. to DIN VDE 0293-308, HD 308 S2
Stranding:	cores stranded in layers
Inner sheath:	halogen-free filling compound, pressed.
Outer sheath:	orange (RAL 2003), polymer compound DIN VDE 0207 part 24, flame retardant

Technical data:

Nominal voltage:	0,6/1 kV
Test voltage:	4 kV
Temperature range:	- 30 °C / + 70 °C
Min. bending radius:	12 x d
Radiation resistance:	up to 200x10 ⁶ cJ/kg

Resistance:



Flame retardant acc. to:
IEC 60332-3-24
EN 50266-2
DIN VDE 0482 part.266-2



Halogen free acc. to:
EN 50267-2-1
IEC 60754-1
DIN VDE 0482 part.267-2-1



Low corrosiveness combustion gases acc.to:
EN 50267-2,
IEC 60754-2,
DIN VDE 0482 part.267-2



Low smoke emission acc. to:
EN 50268-2
IEC 61034-2
DIN VDE 0482 part. 268-2

Features:

Security cable, 0,6/1 kV, with improved fire characteristics

Insulation integrity under flame
propagation to VDE 0472 part 814 IEC 60331

Burning behavior in fire (functionality)
of the complete cable system to DIN 4102
part 12 (90 min.)

FE 180: insulation integrity for 180 min.
Test to DIN VDE 0472 part.814 IEC 60331

E 90: functionally for 90 min. Test to DIN 4102 part.12

○ re: circular solid conductor

⊗ rm: circular stranded conductor

⊘ sm: sector-shaped stranded conductor

△ se: sector-shaped solid conductor

SECURITY CABLES

NHXH-FE 180/E 90



CE



Part no.	No. of cores x cross section n x mm ²	Outer-Ø ca. mm ± 10%	Copper weight kg/km	Cable weight approx. kg/km	AWG no. *)
49140GG2031M15	3G1,5 re	14	43	280	16
49140GG2031M25	3G2,5 re	15	72	330	14
49140GG2031M40	3G4 re	16	115	400	12
49140GG2031M60	3G6 re	17	173	480	10
49140GG2031M61	3G10 re	19	288	650	8
49140GG2031M62	3G16 re	21	461	850	6
49140GG2031M63	3G25 re	25	720	1300	4
49140GG2031M64	3G35 re	28	1008	1700	2
49140GG2035M64	3G35/16 re	28	1162	1850	2
49140GG2035M65	3G50/25 rm	32	1680	2500	1
49140GG2035M66	3G70/35 rm	36	2352	3350	2/0
49140GG2035M67	3G95/50 rm	42	3216	4500	3/0
49140GG2035M68	3G120/70 rm	45	4128	5600	4/0
49140GG2035M69	3G150/70 rm	49	4992	6700	250 MCM
49140GG2035M70	3G185/95 rm	55	6240	8350	350 MCM
49140GG2035M71	3G240/120 rm	63	8064	10000	450 MCM
49140GG2041M15	4G1,5 re	15	58	325	16
49140GG2041M25	4G2,5 re	16	96	385	14
49140GG2041M40	4G4 re	17	154	470	12
49140GG2041M60	4G6 re	18	230	580	10
49140GG2041M61	4G10 re	20	384	790	8
49140GG2041M62	4G16 re	22	614	1100	6
49140GG2041M63	4G25 re	27	960	1650	4
49140GG2041M64	4G35 re	30	1344	2150	2
49140GG2041M65	4G50	34	1920	2800	1
49140GG2041M66	4G70	39	2688	3800	2/0
49140GG2041M67	4G95	44	3648	5050	3/0
49140GG2041M68	4G120	47	4608	6150	4/0
49140GG2051M15	5G1,5	16	72	375	16
49140GG2051M25	5G2,5	17	120	445	14
49140GG2051M40	5G4	18	192	560	12
49140GG2051M60	5G6	20	288	690	10
49140GG2051M61	5G10	22	480	950	8
49140GG2051M62	5G16	24	768	1300	6
49140GG2051M63	5G25	29	1200	1980	4
49140GG2051M64	5G35	33	1680	2350	2
49140GG2051M65	5G50	38	2500	3100	1
49140GG0071M15	7G1,5	19	101	560	16
49140GG0071M25	7G2,5	21	168	650	14
49140GG0101M15	10G1,5	23	144	750	16
49140GG0101M25	10G2,5	25	240	910	14
49140GG0121M15	12G1,5	25	173	850	16
49140GG0121M25	12G2,5	26	288	1000	14

Other dimensions and colours available on request.

SECURITY CABLES

NHXCH-FE 180/E 90



CE

ELETTROTEK KABEL® NHXCH-FE 180/E 90

Construction:

Conductor:	Solid or stranded red copper conductor Cl. 1 or 2, acc. to IEC 60228 DIN VDE 0259
Insulation:	double core insulation of mica tape and cross-linked polymer type HI1, to DIN VDE 0207 part 23
Colour cores:	acc. to DIN VDE 0293-308, HD 308 S2
Stranding:	cores stranded in layers
Wrapping:	glass-fibre. (also for each single core)
Screen:	red copper wires and one or two copper tape(s) applied helically
Outer sheath:	orange (RAL 2003), polymer compound DIN VDE 0207 part 24, flame retardant

Resistance:



Flame retardant acc. to:
IEC 60332-3
EN 50266-2
DIN VDE 0482 part.266-2



Halogen free acc. to:
EN 50267-2-1
IEC 60754-1
DIN VDE 0482 part.267-2-1



Low corrosiveness combustion gases acc.to:
EN 50267-2,
IEC 60754-2,
DIN VDE 0482 part.267-2



Low smoke emission acc. to:
EN 50268-2
IEC 61034-2
DIN VDE 0482 part. 268-2

Technical data:

Nominal voltage:	0,6/1 kV
Test voltage:	4 kV
Temperature range:	- 30 °C / + 70 °C
Min. bending radius:	12 x d
Radiation resistance:	up to 200x10 ⁶ cJ/kg

Features:

Security cable, 0,6/1 kV, with improved fire characteristics

Insulation integrity under flame propagation to VDE 0472 part 814 IEC 60331

Burning behavior in fire (functionality) of the complete cable system to DIN 4102 part 12 (90 min.)

FE 180: insulation integrity for 180 min. Test to DIN VDE 0472 part.814 IEC 60331

E 90: functionally for 90 min. Test to DIN 4102 part.12

○ re: circular solid conductor

⊗ rm: circular stranded conductor

⊘ sm: sector-shaped stranded conductor

△ se: sector-shaped solid conductor

SECURITY CABLES

NHXCH-FE 180/E 90



CE

ELETTROTEK KABEL® NHXCH-FE 180/E 90

Part no.	No. of cores x cross section n x mm ²	Outer-Ø ca. mm ± 10%	Copper weight kg/km	Cable weight approx. kg/km	AWG no. *)
49150GG2031M15	3G1,5/1,5 re	16,9	66	380	16
49150GG2031M25	3G2,5/2,5 re	18	104	430	14
49150GG2031M40	3G4/4 re	19	161	530	12
49150GG2031M60	3G6/6 re	20,1	240	640	10
49150GG2031M61	3G10/10 re	22	408	850	8
49150GG2031M62	3G16/16 rm	24	643	1150	6
49150GG2031M63	3G25/16 rm	28	902	1700	4
49150GG2031M64	3G35/16 rm	30	1190	2150	2
49150GG2031M65	3G50/25 rm	34	1723	2800	1
49150GG2031M66	3G70/35 rm	38	2410	3800	2/0
49150GG2031M67	3G95/50 rm	44	3296	5100	3/0
49150GG2031M68	3G120/70 rm	47	4236	6250	4/0
49150GG2031M69	3G150/70 rm	51	4992	6900	250 MCM
49150GG2031M70	3G185/95 rm	56	6383	8550	350 MCM
49150GG2031M71	3G240/120 rm	65	8242	11150	450 MCM
49150GG2041M15	4G1,5/1,5 re	18	81	435	16
49150GG2041M25	4G2,5/2,5 re	18,9	128	500	14
49150GG2041M40	4G4/4 re	20	200	610	12
49150GG2041M60	4G6/6 re	21	297	740	10
49150GG2041M61	4G10/10 re	23	504	1050	8
49150GG2041M62	4G16/16 re	25	796	1350	6
49150GG2041M63	4G25/16 re	30	1142	1950	4
49150GG2041M64	4G35/16 re	33	1526	2400	2
49150GG2041M65	4G50/25 rm	37	2203	3200	1
49150GG2041M66	4G70/35 rm	42	3082	4300	2/0
49150GG2041M67	4G95/50 rm	47	4208	5750	3/0
49150GG2041M68	4G120/70 rm	51	5388	7100	4/0
49150GG2041M69	4G150/70 rm	56	6540	8550	250 MCM
49150GG2041M70	4G185/95 rm	68	8159	11020	350 MCM
49150GG2041M71	4G240/120 rm	70	10546	14140	450 MCM
49150GG2051M25	5G2,5/2,5 re	-	152	480	14
49150GG0071M15	7G1,5/2,5 re	21	133	520	16
49150GG0071M25	7G2,5/2,5 re	21	200	630	14
49150GG0121M15	12G1,5/2,5 re	27	205	770	16
49150GG0121M25	12G2,5/4 re	28	334	950	14
49150GG0241M15	24G1,5/6 re	37	413	1380	16
49150GG0241M25	24G2,5/10 re	37,5	696	1750	14
49150GG0301M15	30G1,5/6 re	39	499	1360	16
49150GG0301M25	30G2,5/10 re	39,5	840	2080	14

Other dimensions and colours available on request.

SECURITY CABLES

FG4OHM1 PH 30 100/100V



ELETTROTEK KABEL® FG4OHM1 PH 30



Construction:

Conductor:	flexible red copper conductor Cl. 5, acc to IEC 60228
Insulation:	silicon, type EI2
Colour cores:	red/black
Screen:	electrostatic screen of plastic and aluminium tape + tinned drain-wire
Outer sheath:	red (RAL 3000), thermoplastic polyolefine, halogen-free compound, type M1

Technical data:

Nominal voltage:	100/100 V
Test voltage:	2 kV
Temperature at conductor	
<i>in service:</i>	+ 90°C
<i>in short circuit:</i>	+ 250°C
Min. bending radius:	14 x d

Resistance:

	Halogen free acc. to: EN 50267-2-1 IEC 60754-1, DIN VDE 0482 part.267-2-1
	Fire resistant acc. to: IEC 60331 EN 50200

Features:

Fire warning installation cable

PH30: at 830 °C flame and shock for 30 minutes

Suitable for installation in a single conduit or channel or bridge, without interposing separators, with cable system of Category I^o marked "450/750" or "0,6/1 kV" (as required by CEI-UNEL 36762)

Part no.	No. of cores x cross section n x mm ²	Outer-Ø ca. mm ± 10%	Copper weight kg/km	Cable weight approx. kg/km	AWG no. *)
49160BRM020M05	2X0,5	6,1	14,4	39	20
49160BRM020M07	2X0,75	6,4	19,2	49	18
49160BRM020M10	2X1	7,1	24	61	17
49160BRM020M15	2X1,5	8,1	33,6	83	16
49160BRM020M25	2X2,5	9,3	52,8	107	14

Other dimensions and colours available on request.

SECURITY CABLES

GAALFIRE 90 450/750 V



CE



Construction:

- Conductor:** stranded red copper conductor Cl. 2, acc to IEC 60228
- Insulation:** high performance silicon
- Colour cores:** acc. to DIN VDE 0293-308, HD 308 S2
- Outer sheath:** red (RAL 3000),thermoplastic halogen-free compound

Resistance:



Halogen free acc. to:
EN 50267-2-1
IEC 60754-1,
DIN VDE 0482 part.267-2-1



Fire resistant acc. to:
IEC 60331
EN 50200

Technical data:

- Nominal voltage:** 450/750 V
- Temperature range:** - 40 °C / + 90 °C
- Min. bending radius:** 10 x d

Features:

- Fire warning installation cable
- PH90: at 830 °C flame and shock for 90 minutes

Part no.	No.of cores x cross section n x mm ²	Outer-Ø ca.mm ± 10%	Copper weight kg/km	Cable weight approx. kg/km	AWG no.*)
49170ER3020M15	2x1,5	7,8	27	96	16
49170ER3030M15	3x1,5	8,3	43,2	116	16
49170ER3040M15	4x1,5	9,3	57,6	147	16
49170ER3050M15	5x1,5	10,5	72	180	16
49170ER3020M25	2x2,5	9,2	52,8	138	14
49170ER3030M25	3x2,5	9,8	72	169	14
49170ER3040M25	4x2,5	11,3	96	222	14
49170ER3050M25	5x2,5	12,3	120	259	14
49170ER3020M40	2x4	10,5	76,8	189	12
49170ER3030M40	3x4	11,6	115,2	146	12
49170ER3040M40	4x4	12,5	153,6	299	12
49170ER3050M40	5x4	14	192	359	12

Other dimensions and colours available on request.

SECURITY CABLES

GAALFIRE I20 450/750 V





ELETTROTEK KABEL® GAALFIRE I20 450/750 V

Construction:

- Conductor:** flexible red copper conductor Cl. 5, acc to IEC 60228
- Insulation:** high performance silicon
- Colour cores:** acc. to DIN VDE 0293-308, HD 308 S2
- Screen:** electrostatic screen of plastic and aluminium tape + tinned drain-wire
- Outer sheath:** red (RAL 3000), thermoplastic halogen-free compound

Resistance:

-  **Halogen free acc. to:**
EN 50267-2-1
IEC 60754-1,
DIN VDE 0482 part.267-2-1
-  **Fire resistant acc. to:**
IEC 60331
EN 50200

Technical data:

- Nominal voltage:** 450/750 V
- Temperature range:** - 40 °C / + 90 °C
- Min. bending radius:** 8 x d

Features:

- Fire warning installation cable
- PH120: at 830 °C flame and shock for 120 minutes

Part no.	No. of cores x cross section n x mm ²	Outer-Ø ca. mm ± 10%	Copper weight kg/km	Cable weight approx. kg/km	AWG no. *)
49180ER3020M07	2X0,75	7,6	19,2	69	18
49180ER3030M07	3X0,75	8	26,4	84	18
49180ER3040M07	4X0,75	8,7	33,6	103	18
49180ER3020M10	2X1	8	24	78	17
49180ER3030M10	3X1	8,2	33,6	86	17
49180ER3040M10	4X1	8,9	43,2	110	17
49180ER3070M10	7X1	70,8	72	176	17
49180ER3120M10	12X1	13,9	120	275	17
49180ER3190M10	19X1	16,4	187,2	408	17
49180ER3020M15	2X1,5	8,3	33,6	88	16
49180ER3030M15	3X1,5	8,8	48	112	16
49180ER3040M15	4X1,5	9,8	62,4	141	16
49180ER3070M15	7X1,5	11,7	105,6	218	16
49180ER3120M15	12X1,5	15,3	177,6	352	16
49180ER3190M15	19X1,5	18,2	278,4	535	16
49180ER3020M25	2X2,5	9,8	52,8	123	14
49180ER3030M25	3X2,5	10,4	76,8	159	14
49180ER3040M25	4X2,5	11,4	100,8	196	14
49180ER3070M25	7X2,5	13,4	172,8	305	14
49180ER3120M25	12X2,5	17,9	292,8	505	14
49180ER3190M25	19X2,5	21,1	460,8	750	14

Other dimensions and colours available on request.



TELEPHONE AND ELECTRONIC CABLES

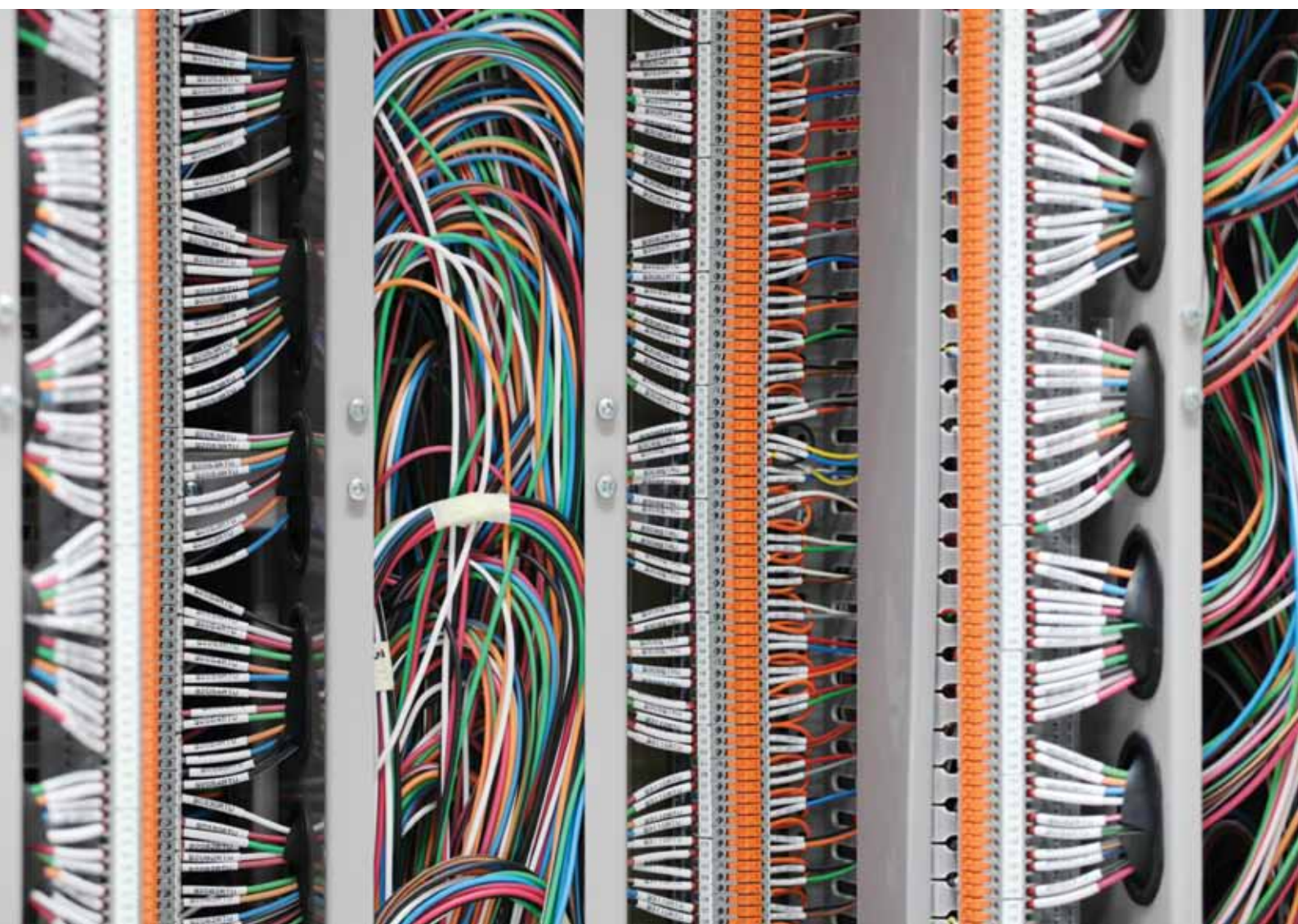

A-2Y(L)2Y



ELETTROTEK KABEL® A 2Y (L) 2Y



Construction:

Conductor:	solid red copper conductor 0,8 mmØ Cl. 1, acc to IEC 60228
Insulation:	PE type 2Y
Colour cores:	DIN VDE 0815
Stranding:	4 cores twisted to a star quad, 5 star quads stranded to sub-units, each 5 or 10 sub units stranded to main units stranded to cable core
Wrapping:	plastic foil
Screen:	electrostatic screen of plastic and aluminium tape + tinned drain-wire
Outer sheath:	black(RAL 9005),PE type 2Y

Features:

- Bd telephone-outdoor cable
- according to VDE 0816
- Laminated sheath
- Unfilled

Technical data:

Nominal voltage:	300 V
Test voltage:	core/core U eff. 500 V core/screen U eff. 2 kV
Temperature range	
<i>Fixed installation:</i>	max + 70 °C
<i>Flexible application:</i>	- 20 °C / + 50 °C
Loop resistance: at 20°C	0,6 mm=130 Ohm/km 0,6 mm=1,04 Ohm/km
Min. bending radius:	10 xd
Radiation resistance:	up to 80x10 ⁶ cJ/kg (up to 80 Mrad)
Insulation resistance:	min.50 MOhm _x /km
Line attenuation: of side circuits at 800 Hz	0,6 mm=1,04 dB/KM 0,8 mm=0,78 dB/KM
Impedance: of side circuits	0,6 mm=720 Ohm 0,8 mm=520 Ohm

TELEPHONE AND ELECTRONIC CABLES

A-2Y(L)2Y



ELETTROTEK KABEL® A 2Y (L) 2Y



Part no.	No. of cores x conductor diameter n x mm	Outer-Ø ca. mm ± 10%	Copper weight kg/km	Cable weight approx. kg/km	AWG no. *)
50010C7V022M06	2x2x0,6	8	11	82	20
50010C7V042M06	4x2x0,6	10	23	127	20
50010C7V062M06	6x2x0,6	11,5	34	132	20
50010C7V102M06	10x2x0,6	12,5	57	171	20
50010C7V202M06	20x2x0,6	15,5	113	268	20
50010C7V302M06	30x2x0,6	17,5	170	358	20
50010C7V402M06	40x2x0,6	19,5	226	438	20
50010C7V502M06	50x2x0,6	21	283	531	20
50010C7V702M06	70x2x0,6	24,5	396	712	20
50010C7VAA2M06	100x2x0,6	28	565	950	20
50010C7VAB2M06	150x2x0,6	33	848	1348	20
50010C7VAC2M06	200x2x0,6	37	1131	1758	20
50010C7VAD2M06	250x2x0,6	40,5	1414	2137	20
50010C7VAE2M06	300x2x0,6	44	1696	2533	20
50010C7VAF2M06	350x2x0,6	47,5	1979	2954	20
50010C7VAG2M06	400x2x0,6	50	2262	3342	20
50010C7V022M08	2x2x0,8	11	20	102	19
50010C7V042M08	4x2x0,8	12	40	158	19
50010C7V062M08	6x2x0,8	13	60	179	19
50010C7V102M08	10x2x0,8	14,5	101	241	19
50010C7V202M08	20x2x0,8	18	201	393	19
50010C7V302M08	30x2x0,8	21	302	540	19
50010C7V402M08	40x2x0,8	23	402	675	19
50010C7V502M08	50x2x0,8	25,5	503	842	19
50010C7V702M08	70x2x0,8	29	704	1105	19
50010C7VAA2M08	100x2x0,8	34	1005	1524	19
50010C7VAB2M08	150x2x0,8	40	1508	2208	19
50010C7VAC2M08	200x2x0,8	46,5	2011	2915	19
50010C7VAD2M08	250x2x0,8	51	2514	3575	19
50010C7VAE2M08	300x2x0,8	53	3016	4232	19
50010C7VAF2M08	350x2x0,8	56,5	3519	4940	19
50010C7VAG2M08	400x2x0,8	60	4022	5565	19
50010C7VAH2M08	500x2x0,8	68	5027	6955	19
50010C7VAI2M08	600x2x0,8	73	6032	8240	19

Other dimensions and colours available on request.

A-2YF(L)2Y



ELETTROTEK KABEL® A-2YF(L)2Y

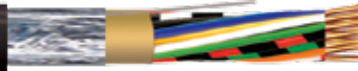

Construction:

Conductor:	solid red copper conductor 0,8 mmØ Cl. 1, acc to IEC 60228
Insulation:	PE type 2Y11
Colour cores:	DIN VDE 0816
Stranding:	4 cores twisted to a star quad, 5 star quads stranded to sub-units, each 5 or 10 sub units stranded to main units stranded to cable core
Wrapping:	paper tape
Screen:	electrostatic screen of plastic and aluminium tape + tinned drain-wire
Outer sheath:	black(RAL 9005),PE type 2YM1

Features:

Bd telephone-outdoor cable
according to VDE 0816
Unfilled
transverse and longitudinally water proof

Technical data:

Nominal voltage:	225 V
Test voltage:	core/core U eff. 500 V core/screen U eff. 2 kV
Temperature range	
<i>Fixed installation:</i>	- 30 °C / + 70 °C
<i>Flexible application:</i>	- 20 °C / + 50 °C
Loop resistance: at 20°C	0,6 mm=130 Ohm/km 0,8 mm=73,2 Ohm/km
Min. bending radius:	7,5 xd
Radiation resistance:	up to 80x10 ⁶ cJ/kg (up to 80 Mrad)
Insulation resistance:	min.50 MOhm/km
Line attenuation: of side circuits at 800 Hz	0,6 mm=1,04 dB/KM 0,8 mm=0,78 dB/KM
Impedance: of side circuits	0,6 mm=720 Ohm 0,8 mm=520 Ohm

TELEPHONE AND ELECTRONIC CABLES

A-2YF(L)2Y



ELETTROTEK KABEL® A-2YF(L)2Y

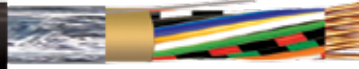

Part no.	No. of cores x conductor diameter n x mm	Outer-Ø ca.mm ± 10%	Copper weight kg/km	Cable weight approx. kg/km	AWG no.*)
50020C7V022M06	2x2x0,6	7,5	11	80	20
50020C7V042M06	4x2x0,6	9	23	140	20
50020C7V062M06	6x2x0,6	12	34	150	20
50020C7V102M06	10x2x0,6	13,5	57	190	20
50020C7V202M06	20x2x0,6	16	113	310	20
50020C7V302M06	30x2x0,6	19	170	430	20
50020C7V402M06	40x2x0,6	20,5	226	545	20
50020C7V502M06	50x2x0,6	23	283	660	20
50020C7V702M06	70x2x0,6	26	396	895	20
50020C7VAA2M06	100x2x0,6	31,5	565	1230	20
50020C7VAB2M06	150x2x0,6	37,5	848	1780	20
50020C7VAC2M06	200x2x0,6	42,5	1131	2320	20
50020C7VAD2M06	250x2x0,6	47,5	1414	2910	20
50020C7VAE2M06	300x2x0,6	51,5	1696	3490	20
50020C7VAF2M06	350x2x0,6	55	1979	3970	20
50020C7VAG2M06	400x2x0,6	60,5	2262	4480	20
50020C7VAH2M06	500x2x0,6	60,5	2262	5460	20
50020C7V022M08	2x2x0,8	8,5	20,0	100	19
50020C7V042M08	4x2x0,8	10	40,0	180	19
50020C7V062M08	6x2x0,8	12,5	60,0	190	19
50020C7V102M08	10x2x0,8	15	101,0	280	19
50020C7V202M08	20x2x0,8	19	201,0	480	19
50020C7V302M08	30x2x0,8	23	302,0	670	19
50020C7V402M08	40x2x0,8	26	402,0	860	19
50020C7V502M08	50x2x0,8	29	503,0	1060	19
50020C7V702M08	70x2x0,8	33	704,0	1420	19
50020C7VAA2M08	100x2x0,8	39	1005,0	1980	19
50020C7VAB2M08	150x2x0,8	47	1508,0	2940	19
50020C7VAC2M08	200x2x0,8	51	2011,0	3780	19
50020C7VAD2M08	250x2x0,8	58	2514,0	4660	19
50020C7VAE2M08	300x2x0,8	62,5	3016,0	5570	19
50020C7VAF2M08	350x2x0,8	68	3519,0	6750	19
50020C7VAG2M08	400x2x0,8	73	4022,0	7630	19
50020C7VAH2M08	500x2x0,8	81,5	5027,0	9540	19

Other dimensions and colours available on request.

TELEPHONE AND ELECTRONIC CABLES

A-Y(St)YSYv



ELETTROTEK KABEL® A-Y(St)YSYv



Construction:

Conductor:	solid red copper conductor 0,8 mmØ Cl. 1, acc to IEC 60228
Insulation:	PVC,type Y11
Colour cores:	DIN VDE 0816
Stranding:	4 cores twisted to a star quad, 5 star quads stranded to sub-units,each 5 or 10 sub units stranded to main units stranded to cable core
Screen:	electrostatic screen of plastic and aluminium tape + tinned drain-wire
Inner sheath:	PVC type YM1
Armouring:	braid of galvanized steel wires
Outer sheath:	black(RAL 9005),PVC type YM1

Features:

Acc. to VDE 0815
 UV resistant
 underground use
 rodent protection acc. to standard HD 22.10.S1 and
 DIN VDE 0282 T10

Technical data:

Nominal voltage:	300 V
Test voltage:	500 V
Temperature range	
<i>Fixed installation:</i>	-30 /+70°C
<i>Flexible application:</i>	- 5 /+50°C
Min. bending radius:	10 xd
Operating capacity:	120 nF/km
Insulation resistance:	100 MOhm \times /km
Loop resistance:	73,2 Ohm/km

Applications:

For fixed installation, indoors, outdoors.
 in ground, as well as in concrete.

Part no.	No.of cores x conductor diameter n x mm	Outer-Ø ca.mm ± 10%	Copper weight kg/km	Cable weight approx. kg/km	AWG no.*)
50030C7V022M08	2x2x0,8 SW	11	25	180	19
50030C7V042M08	4x2x0,8 SW	12,5	45	235	19
50030C7V082M08	8x2x0,8 SW	15,5	85	340	19
50030C7V122M08	12x2x0,8 SW	16	126	410	19
50030C7V202M08	20x2x0,8 SW	19	206	560	19
50030C7V402M08	40x2x0,8 SW	26	407	960	19

Other dimensions and colours available on request.

J-YY Bd



ELETTROTEK KABEL® J-YY Bd

Construction:

Conductor:	solid red copper conductor 0,6 mmØ Cl. 1, acc to IEC 60228
Insulation:	PVC core insulation, compound type Y11 to DIN VDE 0207, insulation wall- thickness 0,2 mm to table 7
Colour cores:	DIN VDE 0815
Stranding:	the cores to a quad each 5 quads to a unit and several units are stranded in layer
Wrapping:	plastic foil
Outer sheath:	grey (RAL 7032), PVC, type YM1

Resistance:



Flame retardant and self extinguishing acc. to:
DIN VDE 0482 part 332-1-2
EN 60332-1-2
IEC 60332-1-2

Technical data:

Nominal voltage:	300 V
Test voltage: (50 Hz)	core/core U eff. 800 V
Temperature range	
<i>Fixed installation:</i>	- 30°C / +70°C
<i>Flexible application:</i>	- 5 °C / + 50 °C
Loop resistance: at 20°C	max. 130 Ohm/km
Min. bending radius	
<i>to DIN VDE 0891 part 5 during delivery:</i>	7,5 xd
<i>single bending without tension:</i>	2,5 xd
<i>repeated bending without tension:</i>	7,5 xd
Radiation resistance:	up to 80x10 ⁶ cJ/kg (up to 80 Mrad)
Insulation resistance:	min. 100 MOhm·km
Line attenuation: at 800 Hz	1,04 dB/KM
Impedance: of side circuits	0,6 mm=720 Ohm 0,8 mm=520 Ohm
Mutual capacitance: at 800 Hz	max. 100 nF/km
Capacitance unbalances at 800 Hz:	k ₁ max. 300 pF/100 m k ₉ k ₁₂ 100 pF/100 m

Features:

telephone installation cable
according to VDE 0816

TELEPHONE AND ELECTRONIC CABLES

J-YY Bd



Part no.	No. of cores x conductor diameter n x mm	Outer-Ø ca. mm ± 10%	Copper weight kg/km	Cable weight approx. kg/km	AWG no. *)
50040C6W022M06	2x2x0,6	4,5	11	34	20
50047C6W022M06	2x2x0,6 T	5	14	40	20
50040C6W042M06	4x2x0,6	6,5	23	59	20
50047C6W042M06	4x2x0,6T	7	26	65	20
50040C6W062M06	6x2x0,6	7	34	74	20
50047C6W062M06	6x2x0,6T	7,5	37	80	20
50040C6W102M06	10x2x0,6	8,5	57	111	20
50040C6W162M06	16x2x0,6	10	90	160	20
50040C6W202M06	20x2x0,6	11	113	200	20
50040C6W242M06	24x2x0,6	11,5	136	224	20
50040C6W302M06	30x2x0,6	13	170	284	20
50040C6W402M06	40x2x0,6	15	226	364	20
50040C6W502M06	50x2x0,6	16,5	283	451	20
50040C6W602M06	60x2x0,6	17,5	339	529	20
50040C6W802M06	80x2x0,6	20,3	452	700	20
50040C6WAA2M06	100x2x0,6	22,3	565	850	20

Other dimensions and colours available on request.

J-Y(St)Y Lg



ELETTROTEK KABEL® J-Y(St)Y Lg

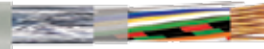

Construction:

Conductor:	solid red copper conductor 0,8 mmØ Cl. 1, acc to IEC 60228
Insulation:	PVC core insulation, compound type Y11 to DIN VDE 0207, insulation wall-thickness 0,2 mm to table 7
Colour cores:	DIN VDE 0815
Stranding:	the cores to a quad each 5 quads to a unit and several units are stranded in layer
Wrapping:	tinned copper drain wire, plastic coated
Screen:	electrostatic screen of plastic and aluminium tape + tinned drain-wire
Outer sheath:	grey (RAL 7032), PVC, type YM1

Resistance:



Flame retardant and self extinguishing acc. to:
DIN VDE 0482 part 332-1-2
EN 60332-1-2
IEC 60332-1-2

Technical data:

Nominal voltage:	0,6 mm-300 V 0,8 mm-300 V
Test voltage: (50 Hz)	core/core U eff. 800 V core/screen 800 V
Temperature range	
<i>Fixed installation:</i>	- 30°C / +70°C
<i>Flexible application:</i>	- 5 °C / + 50 °C
Loop resistance: at 20°C	0,6 mm-max. 130 Ohm/km 0,6 mm-max. 73,2 Ohm/km
Min. bending radius	
<i>to DIN VDE 0891 part 5 during delivery:</i>	7,5 xd
<i>single bending without tension:</i>	2,5 xd
<i>repeated bending without tension:</i>	7,5 xd
Radiation resistance:	up to 80x10 ⁶ cJ/kg (up to 80 Mrad)
Insulation resistance:	min. 100 MOhm x/km
Line attenuation: at 800 Hz	1,04 dB/KM
Impedance: of side circuits	0,6 mm=720 Ohm 0,8 mm=520 Ohm
Mutual capacitance: at 800 Hz	max. 100 nF/km
Capacitance unbalances: at 800 Hz:	k ₁ max. 300 pF/100 m k ₉ , k ₁₂ 100 pF/100 m

Features:

telephone installation cable

according to VDE 0815

TELEPHONE AND ELECTRONIC CABLES

J-Y(St)Y Lg



ELETTROTEK KABEL® J-Y(St)Y Lg



Part no.	No. of cores x conductor diameter n x mm	Outer-Ø ca. mm ± 10%	Copper weight kg/km	Cable weight approx. kg/km	AWG no. *)
50050C6W022M08	2x2x0,8	7	21	60	19
50050C6W032M08	3x2x0,8	8,5	31	80	19
50050C6W042M08	4x2x0,8	9	41	100	19
50050C6W052M08	5x2x0,8	9,5	52	120	19
50050C6W062M08	6x2x0,8	11	62	140	19
50050C6W082M08	8x2x0,8	11,5	82	170	19
50050C6W102M08	10x2x0,8	13,2	102	220	19
50050C6W122M08	12x2x0,8	14,2	123	250	19
50050C6W162M08	16x2x0,8	16	164	320	19
50050C6W202M08	20x2x0,8	17	204	380	19
50050C6W242M08	24x2x0,8	19	244	460	19
50050C6W302M08	30x2x0,8	20,8	304	560	19
50050C6W402M08	40x2x0,8	23	405	710	19
50050C6W502M08	50x2x0,8	26	505	900	19
50050C6W602M08	60x2x0,8	28	606	1050	19
50050C6W802M08	80x2x0,8	31,5	807	1400	19
50050C6WAA2M08	100x2x0,8	33	1008	1750	19
50050C6W022M06	2x2x0,6	5	13	40	20
50050C6W032M06	3x2x0,6	6,3	18	50	20
50050C6W042M06	4x2x0,6	6,5	24	60	20
50050C6W052M06	5x2x0,6	7,2	30	70	20
50050C6W062M06	6x2x0,6	7,5	35	80	20
50050C6W082M06	8x2x0,6	8	46	90	20
50050C6W102M06	10x2x0,6	10	58	110	20
50050C6W122M06	12x2x0,6	10,2	71	130	20
50050C6W162M06	16x2x0,6	11	93	160	20
50050C6W202M06	20x2x0,6	12	116	190	20
50050C6W242M06	24x2x0,6	13	139	220	20
50050C6W302M06	30x2x0,6	14	172	280	20
50050C6W402M06	40x2x0,6	15	220	350	20
50050C6W502M06	50x2x0,6	17	286	430	20
50050C6W602M06	60x2x0,6	19	342	500	20
50050C6W802M06	80x2x0,6	21	455	640	20
50050C6WAA2M06	100x2x0,6	24	568	850	20

Other dimensions and colours available on request.

TELEPHONE AND ELECTRONIC CABLES

J-2Y(St)H



ELETTROTEK KABEL® J-2Y(St)H

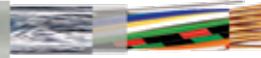

Construction:

Conductor:	solid red copper conductor Cl. 1, acc to IEC 60228
Insulation:	PE type 2Y
Colour cores:	DIN VDE 0815
Stranding:	conductors twisted to 5 quads, twisted to units
Screen:	electrostatic screen of plastic and aluminium tape + tinned drain-wire
Outer sheath:	grey (RAL...), polymer compound flame retardant, halogen free

Resistance:



Flame retardant acc. to:
IEC 60332-3
EN 50266-2
DIN VDE 0482 part.266-2



Halogen free acc. to:
EN 50267-2-1
IEC 60754-1
DIN VDE 0482 part.267-2-1

Technical data:

Nominal voltage:	300 V
Test voltage: (50 Hz)	800 V
Temperature range	
<i>Fixed installation:</i>	- 30°C / +70°C
<i>Flexible application:</i>	- 5 °C / + 70 °C
Loop resistance: at 20°C	max. 130 Ohm/km
Min. bending radius	
<i>fixed laying:</i>	10 x d

Features:

St III Bd 16 Mbits/s (Kat.3) ISDN/EDV
(Z = 100 Ohm)

Part no.	No. of cores x conductor diameter n x mm	Outer-Ø ca. mm ± 10%	Copper weight kg/km	Cable weight approx. kg/km	AWG no. *)
50060C6W022M06	2x2x0,6	5,8	13	44	20
50060C6W042M06	4x2x0,6	9,2	24	80	20
50060C6W062M06	6x2x0,6	9,3	35	86	20
50060C6W082M06	8x2x0,6	9,5	46	105	20
50060C6W102M06	10x2x0,6	9,8	58	112	20
50060C6W202M06	20x2x0,6	12,7	116	218	20
50060C6W302M06	30x2x0,6	15	172	302	20
50060C6W402M06	40x2x0,6	16,8	229	376	20
50060C6W502M06	50x2x0,6	18,5	266	480	20
50060C6W602M06	60x2x0,6	20,2	342	560	20
50060C6W802M06	80x2x0,6	23	455	748	20
50060C6WAA2M06	100x2x0,6	25,2	588	940	20

Other dimensions and colours available on request.

TELEPHONE AND ELECTRONIC CABLES

J-H(St)H
installation cable



ELETTROTEK KABEL® J-H(St)H

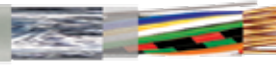

Construction:

Conductor:	solid red copper conductor Cl. 1, acc to IEC 60228
Insulation:	halogen-free compound type HI2, to DIN VDE part 23
Colour cores:	DIN VDE 0815
Stranding:	cores twisted in quads, quads stranded to units
Wrapping:	plastic tape
Screen:	electrostatic screen of plastic and aluminium tape + tinned drain-wire
Outer sheath:	grey (RAL...), halogen free, type HM2

Resistance:



Flame retardant acc. to:
IEC 60332-3
EN 50266-2
DIN VDE 0482 part.266-2



Halogen free acc. to:
EN 50267-2-1
IEC 60754-1
DIN VDE 0482 part.267-2-1



Low corrosiveness combustion gases:
IEC 60754-2
EN 50267-2-2
DIN VDE 0482 part.267-2-1



Low smoke emission acc. to:
EN 50268-2
IEC 61034-2
DIN VDE 0482 part. 268-2

Technical data:

Nominal voltage:	300 V
Test voltage:	800 V
Temperature range	
<i>Fixed installation:</i>	- 30°C / +70°C
<i>Flexible application:</i>	- 5 °C / + 70 °C
Min. bending radius	
<i>fixed laying:</i>	2,5 x d
<i>Flexible application:</i>	7,5 x d
Radiation resistance:	up to 100x10 ⁶ cJ/kg

Features:

Bd installation cable

Part no.	No. of cores x conductor diameter n x mm	Outer-Ø ca. mm ± 10%	Copper weight kg/km	Cable weight approx. kg/km	AWG no. *)
50070C6W022M06	2x2x0,6	5,8	14	50	20
50070C6W042M06	4x2x0,6	8,6	25	91	20
50070C6W062M06	6x2x0,6	9	37	100	20
50070C6W102M06	10x2x0,6	10,3	59	147	20
50070C6W202M06	20x2x0,6	15,5	116	308	20
50070C6W302M06	30x2x0,6	16,5	172	350	20
50070C6W402M06	40x2x0,6	18,6	229	465	20
50070C6W502M06	50x2x0,6	20,7	286	571	20
50070C6W602M06	60x2x0,6	22,8	342	662	20
50070C6W802M06	80x2x0,6	26,6	455	877	20
50070C6WAA2M06	100x2x0,6	28,2	568	1055	20
50070C6W022M08	2x2x0,8	6,8	25	70	19
50070C6W042M08	4x2x0,8	10,5	45	135	19
50070C6W062M08	6x2x0,8	10,9	65	151	19
50070C6W102M08	10x2x0,8	13,1	106	230	19
50070C6W202M08	20x2x0,8	20,4	206	507	19
50070C6W302M08	30x2x0,8	21,5	307	600	19
50070C6W402M08	40x2x0,8	24,5	407	788	19
50070C6W502M08	50x2x0,8	27,1	508	972	19
50070C6W602M08	60x2x0,8	29,4	608	1120	19
50070C6W802M08	80x2x0,8	33,2	809	1475	19
50070C6WAA2M08	100x2x0,8	37,2	1010	1804	19

Other dimensions and colours available on request.

JE-Y(St)Y

Bd Si industry-electronic cable acc.to DIN VDE 0815



ELETTROTEK KABEL® JE-Y(St)Y

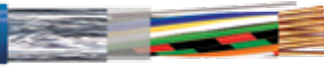

Construction:

Conductor:	solid red copper conductor Cl. 1, acc to IEC 60228
Insulation:	Special PVC, type Y13, to DIN VDE 0207 part.4
Colour cores:	DIN VDE 0815 (with ring colours and ring groups)
Stranding:	2 core twisted in pair, 4 pairs to a unit and several units stranded in layers (for 2 pairs cable, 4 cores stranded to a quad)
Wrapping:	plastic tape
Screen:	electrostatic screen of plastic and aluminium tape + tinned drain-wire
Outer sheath:	grey (RAL 7032) or blue (RAL 5015) special PVC type YM1

Resistance:



Flame retardant and self extinguishing acc. to:
DIN VDE 0482 part 332-1-2
EN 60332-1-2
IEC 60332-1-2

Technical data:

Nominal voltage:	300 V
Test voltage: (50 Hz)	2 kV
Temperature range	
<i>Fixed installation:</i>	- 30°C / +70°C
<i>Flexible application:</i>	- 5 °C / + 50 °C
Min. bending radius	
<i>fixed laying:</i>	5 x d
Radiation resistance:	up to 80x10 ⁶ cJ/kg

Features:

Bd industry-electronic cable

TELEPHONE AND ELECTRONIC CABLES

JE-Y(St)Y

Bd Si industry-electronic cable acc.to DIN VDE 0815



ELETTROTEK KABEL® JE-Y(St)Y

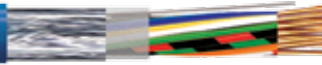

BLUE:

Part no.	No. of cores x conductor diameter n x mm	Outer-Ø ca.mm ± 10%	Copper weight kg/km	Cable weight approx. kg/km	AWG no. *)
50080CBW012M08	1x2x0,8	5	15	40	20
50080CBW022M08	2x2x0,8	7	25	60	20
50080CBW042M08	4x2x0,8	9	45	95	20
50080CBW082M08	8x2x0,8	11	85	160	20
50080CBW122M08	12x2x0,8	14	125	235	20
50080CBW162M08	16x2x0,8	15	165	295	20
50080CBW202M08	20x2x0,8	16	205	355	20
50080CBW322M08	32x2x0,8	20	325	555	20
50080CBW402M08	40x2x0,8	22	405	670	20

GREY:

Part no.	No. of cores x conductor diameter n x mm	Outer-Ø ca.mm ± 10%	Copper weight kg/km	Cable weight approx. kg/km	AWG no. *)
50080C6W012M08	1x2x0,8	5	15	40	20
50080C6W022M08	2x2x0,8	7	25	60	20
50080C6W042M08	4x2x0,8	9	45	95	20
50080C6W082M08	8x2x0,8	11	85	160	20
50080C6W122M08	12x2x0,8	14	125	235	20
50080C6W162M08	16x2x0,8	15	165	295	20
50080C6W202M08	20x2x0,8	16	205	355	20
50080C6W322M08	32x2x0,8	20	325	555	20
50080C6W402M08	40x2x0,8	22	405	670	20

Other dimensions and colours available on request.

JE-LiYCY

Bd Si industry-electronic cable acc.to DIN VDE 0815



ELETTROTEK KABEL® JE-LIYCY



Construction:

Conductor:	stranded red copper conductor Cl. 2, acc to IEC 60228
Insulation:	PVC, type YI3,
Colour cores:	DIN VDE 0815 (with ring colours and ring groups)
Stranding:	2 core twisted in pair, 4 pairs to a unit and several units stranded in layers (for 2 pairs cable, 4 cores stranded to a quad)
Wrapping:	plastic tape
Screen:	tinned copper braid coverage approx. 85%
Outer sheath:	grey (RAL 7032) or blue (RAL 5015) special PVC type YM1

Resistance:



Flame retardant and self extinguishing acc. to:
DIN VDE 0482 part 332-1-2
EN 60332-1-2
IEC 60332-1-2

Technical data:

Nominal voltage:	300 V
Test voltage: (50 Hz)	2 kV
Temperature range	
<i>Fixed installation:</i>	- 30°C / +70°C
<i>Flexible application:</i>	- 5 °C / + 50 °C
Min. bending radius	
<i>fixed laying:</i>	5 x d
Radiation resistance:	up to 80x10 ⁶ cJ/kg

TELEPHONE AND ELECTRONIC CABLES

JE-LiYCY

Bd Si industry-electronic cable acc.to DIN VDE 0815



ELETTROTEK KABEL® JE-LiYCY

GREY:

Part no.	No.of cores x cross section n x mm ²	Outer-Ø ca.mm ± 10%	Copper weight kg/km	Cable weight approx. kg/km	AWG no.)*
50090C6W022M05	2x2x0,5	9	44	102	20
50090C6W042M05	4x2x0,5	12	80	168	20
50090C6W082M05	8x2x0,5	17	152	297	20
50090C6W122M05	12x2x0,5	18	192	357	20
50090C6W202M05	20x2x0,5	22	288	555	20
50090C6W322M05	32x2x0,5	26	439	852	20
50090C6W402M05	40x2x0,5	29	531	1005	20

BLUE:

Part no.	No.of cores x cross section n x mm ²	Outer-Ø ca.mm ± 10%	Copper weight kg/km	Cable weight approx. kg/km	AWG no.)*
50090CBW022M05	2x2x0,5	9	44	102	20
50090CBW042M05	4x2x0,5	12	80	168	20
50090CBW082M05	8x2x0,5	17	152	297	20
50090CBW122M05	12x2x0,5	18	192	357	20
50090CBW202M05	20x2x0,5	22	288	555	20
50090CBW322M05	32x2x0,5	26	439	852	20
50090CBW402M05	40x2x0,5	29	531	1005	20

Other dimensions and colours available on request.

TELEPHONE AND ELECTRONIC CABLES

JE-LiHCH



ELETTROTEK KABEL® JE-LiHCH

Construction:

Conductor:	stranded red copper conductor Cl. 2, acc to IEC 60228
Insulation:	Halogen-free core insulation, type HI1 or HI2 to DIN VDE part 23, insulation wall thickness 0,3 mm
Colour cores:	DIN VDE 0815 (with ring colours and ring groups)
Stranding:	2 core twisted in pair, 4 pairs to a unit and several units stranded in layers (for 2 pairs cable, 4 cores stranded to a quad)
Wrapping:	plastic tape
Screen:	tinned copper braid coverage approx. 85%
Outer sheath:	grey (RAL 7032) or blue (RAL 5015) halogen free compound type HM1 or HM2

Resistance:



Flame retardant acc. to:
IEC 60332-3
EN 50266-2
DIN VDE 0482 part.266-2



Halogen free acc. to:
EN 50267-2-1
IEC 60754-1
DIN VDE 0482 part.267-2-1



Low corrosiveness combustion gases:
IEC 60754-2
EN 50267-2-2
DIN VDE 0482 part.267-2



Low smoke emission acc. to:
EN 50268-2
IEC 61034-2
DIN VDE 0482 part. 268-2

Technical data:

Nominal voltage:	300 V
Test voltage:	2 kV
Temperature range	
<i>Fixed installation:</i>	- 30°C / +70°C
<i>Flexible application:</i>	- 5 °C / + 50 °C
Min. bending radius	7,5 x d
Radiation resistance:	up to 100x10 ⁶ cJ/kg

Features:

Bd industry-electronic cable

Part no.	No. of cores x cross section n x mm ²	Outer-Ø ca. mm ± 10%	Copper weight kg/km	Cable weight approx. kg/km	AWG no. *)
50100C6W022M05	2x2x0,5	9	44	102	20
50100C6W042M05	4x2x0,5	12	80	168	20
50100C6W082M05	8x2x0,5	17	152	297	20
50100C6W122M05	12x2x0,5	18	192	357	20
50100C6W202M05	20x2x0,5	22	288	555	20
50100C6W322M05	32x2x0,5	26	439	852	20
50100C6W402M05	40x2x0,5	29	531	1005	20

Other dimensions and colours available on request.



GAALSHIP® MARINE CABLES



INTRODUCTION

With our range of GAALSHIP® Marine cables we want to offer the best service to our customer, both to distributors and end customers, to shipyards, marine installer and to owners.

Our GAALSHIP® Marine cables are suitable for all possible uses on board, their high flexibility helps to facilitate the installations as well as their small diameters helps to save space on the ship.

GAALSHIP® Marine cables are Halogen Free and Low Smoke, these cables features will be useful in case of fire in order to maintain a good visibility and to save passengers lives. Moreover, thanks to these characteristics GAALSHIP® Marine Cables respect the environment.

We firmly believe that our competence in finding the best cable solution according to our customers requests will increase the productivity and the satisfaction of the end users.

We work with the most important Brands of Marine cables Producers, approved by the following Certification Authorities:

Det Norske Veritas (DNV)

Lloyd's Register (LR)

Germanischer Lloyd (GL)

Bureau Veritas (BV)

Registro Italiano Navale (RINA)

American Bureau of Shipping (ABS)

Russian Maritime Register of Shipping (RMRS)

China Classification Society (CCS)

NORMATIVES

GAALSHIP® MARINE Cables cables according to:

IEC 60092-350:	General construction and test requirement.
IEC 60092-351:	Insulating materials for shipboard power cables.
IEC 60092-352:	Choice and installation of electric cables.
IEC 60092-353:	Single and multicore cables with extruded solid insulation for rated voltages 0.6/1 and 1.8/3 kV.
IEC 60092-354:	Single and three-core power cables with extruded solid insulation for rated voltages 6 and 30 kV.
IEC 60092-359:	Sheating materials for shipboard power cables.
IEC 60092-376 (2003-05):	150/250 V cables for control and instrumentation circuits.
IEC 60228:	Conductors of insulated cables.
IEC 60331 :	Fire resisting characteristics of electrical cables.
IEC 60332-1-2:	Test on a single vertical insulated wire or cable.
IEC 60332-3-22:	Test on bunched wires or cables.
IEC 60754-1/60754-2:	Test on gases evolved during combustion of materials from cable.
IEC 60811:	Common test methods for insulating and sheating materials of electric cables.
IEC 61034-1/61034-2:	Measurements of smoke density of electric cable burning under defined conditions.

Legend:

Code	Cable elements
HF	Halogen free cables, XLPE insulated, stranded conductor CL.2, Cl.5
U	Unarmoured
A	Copper or galvanized steel wire braid armoured
IS	Individual electrostatic screen
OS	Overall electrostatic screen
FR	Fire resistant cables (test to IEC 60331)
MV	Prefix for medium voltage cables

Cores identification:

Insulation colour scheme:

0,6/1 kV Power and control cables

N. of cores	Cores colour				
1x...	-	-	-	Black	-
2x...	-	Blue	Brown	-	-
3G...	Green/Yellow	Blue	Brown	-	-
3x...	-	-	Brown	Black	Grey
4G...	Green/Yellow	-	Brown	Black	Grey
4x...	-	Blue	Brown	Black	Grey
5G..	Green/Yellow	Blue	Brown	Black	Grey
> 5	Black and numbered				

150 / 250V Instrumentation cables

N. of cores	Cores colour
Pair	Blue, Black
Triples	Blue, Brown, Black

Pairs and triples are numbered on each core (e.g. 1-1-, 2-2-...)

from 3,6 to 12/20 kV MV cables

1x...:	natural colour of the compound
3x...:	natural colour of the compound + numbered tape(s) or coloured tapes or thread

Outer sheath colours (STANDARDS COLOURS)

Instrumentation and control	ORANGE
Power LV up 5 cores	BLACK
(exception 3G1,5; 3G2,5; 4G1,5; 4G2,5)	GREEN
Power MV	RED
Other colours available on request	

GAALSHIP® DATA HF 350

Halogen-free, flexible data cable 350V



ELETTROTEK KABEL® GAALSHIP® DATA HF 350



Construction:

Conductor:	flexible tinned copper conductor Cl. 5, acc to IEC 60228, DIN VDE 0295
Insulation:	Halogen-free compound
Colour core:	acc. to DIN 47100
Stranding:	In layers
Outer sheath:	grey (RAL 7001) Halogen-free compound

Technical data:

Nominal voltage:	max. 350 V
Test voltage:	1500 V
Temperature range:	
<i>Fixed laying:</i>	-40 up to +90 °C
<i>Flexible application:</i>	-30 up to +90 °C
Min. bending radius:	
<i>Fixed laying:</i>	5 x d
<i>Flexible application:</i>	10 x d

Resistance:



Self-extinguishing, flame retardant and no flame propagation acc. to:

DIN EN 60332-1-2,
IEC 60332-1-2,
DIN EN 60332-3-22,
IEC 60332-3-22



Halogen free acc. to:

EN 50267-2-1,
IEC 60754-1



Corrosiveness of conflagration gases acc. to:

DIN EN 50267-2-2,
IEC 60754-2



Smoke density acc. to:

EN 61034,
IEC 61034

Features:

On request class 2

We have possibility to provide the following Certifications on request:

Det Norske Veritas (DNV)
Lloyd's Register (LR)
Germanischer Lloyd (GL)
Bureau Veritas (BV)
Registro Italiano Navale (RINA)
American Bureau of Shipping (ABS)
Other approvals on request



Available on stock CABLE GLANDS: see page 404 up to 416 of catalogue.

GAALSHIP® DATA HF 350

Halogen-free, flexible data cable 350V



ELETTROTEK KABEL® GAALSHIP® DATA HF 350



Part no.	No. of cores x cross section n x mm ²	Outer-Ø ca.mm ± 10%	Copper weight kg/km	Cable weight approx. kg/km	AWG no.*)
11010C54020M01	2 x 0,14	3,7	3	20	26
11010C54030M01	3 x 0,14	4,0	4,2	22	26
11010C54040M01	4 x 0,14	4,1	5,5	25	26
11010C54050M01	5 x 0,14	4,2	6,9	30	26
11010C54060M01	6 x 0,14	4,6	8,2	35	26
11010C54070M01	7 x 0,14	5,0	9,5	38	26
11010C54080M01	8 x 0,14	5,0	11	40	26
11010C54120M01	12 x 0,14	5,7	16,3	58	26
11010C54160M01	16 x 0,14	6,5	21,7	72	26
11010C54020M02	2 x 0,25	7,2	5	20	24
11010C54030M02	3 x 0,25	4,0	7,5	25	24
11010C54040M02	4 x 0,25	4,2	9,8	30	24
11010C54050M02	5 x 0,25	4,7	12,2	39	24
11010C54060M02	6 x 0,25	5,0	14,5	45	24
11010C54070M02	7 x 0,25	5,5	17	48	24
11010C54080M02	8 x 0,25	5,5	19	58	24
11010C54120M02	12 x 0,25	6,5	29	75	24
11010C54160M02	16 x 0,25	7,2	38,5	95	24
11010C54020M03	2 x 0,34	7,9	6,8	30	22
11010C54030M03	3 x 0,34	4,5	10	35	22
11010C54040M03	4 x 0,34	4,8	13,4	40	22
11010C54050M03	5 x 0,34	5,2	16,5	49	22
11010C54060M03	6 x 0,34	5,5	19,8	60	22
11010C54070M03	7 x 0,34	6,3	23	63	22
11010C54080M03	8 x 0,34	7,2	26	75	22
11010C54120M03	12 x 0,34	8,0	39	98	22
11010C54160M03	16 x 0,34	9,2	52,8	130	22
11010C54020M05	2 x 0,5	5,0	9,8	38	20
11010C54030M05	3 x 0,5	5,2	14,5	40	20
11010C54040M05	4 x 0,5	5,5	19	51	20
11010C54050M05	5 x 0,5	6,3	24,3	65	20
11010C54060M05	6 x 0,5	6,8	29	75	20
11010C54070M05	7 x 0,5	6,8	33,5	80	20
11010C54080M05	8 x 0,5	7,9	38,5	95	20
11010C54120M05	12 x 0,5	9,2	57,5	135	20
11010C54160M05	16 x 0,5	1,2	77	170	20
11010C54020M07	2 x 0,75	5,5	14,5	45	19
11010C54030M07	3 x 0,75	5,7	21,5	50	19
11010C54040M07	4 x 0,75	6,5	29	65	19
11010C54050M07	5 x 0,75	7,0	36,2	80	19
11010C54060M07	6 x 0,75	7,5	43,5	90	19
11010C54070M07	7 x 0,75	7,5	50,5	100	19
11010C54080M07	8 x 0,75	9,0	57,5	125	19
11010C54120M07	12 x 0,75	10,3	86,5	165	19
11010C54160M07	16 x 0,75	11,3	115	210	19

Other dimensions and colors available on request.

GAALSHIP® DATA HF 350 A

Armoured, halogen-free flexible data cable 350 V



ELETTROTEK KABEL® GAALSHIP® DATA HF 350 A



Construction:

Conductor:	flexible tinned copper conductor Cl. 5, acc to IEC 60228, DIN VDE 0295
Insulation:	Halogen-free compound
Colour core:	acc. to DIN 47100
Stranding:	In layers
Wrapping:	PETP foil
Armouring:	tinned copper braiding
Outer sheath:	grey (RAL 7001) Halogen-free compound

Technical data:

Nominal voltage:	max. 350 V
Test voltage:	1500 V
Temperature range:	
<i>Fixed laying:</i>	-40 up to +90 °C
<i>Flexible application:</i>	-30 up to +90 °C
Min. bending radius:	
<i>Fixed laying:</i>	5 x d
<i>Flexible application:</i>	10 x d

Resistance:



Self-extinguishing, flame retardant and no flame propagation acc. to:

DIN EN 60332-1-2,
IEC 60332-1-2,
DIN EN 60332-3-22,
IEC 60332-3-22



Halogen free acc. to:

EN 50267-2-1,
IEC 60754-1



Corrosiveness of conflagration gases acc. to:

DIN EN 50267-2-2,
IEC 60754-2



Smoke density acc. to:

EN 61034,
IEC 61034

Features:

On request class 2

We have possibility to provide the following Certifications on request:

Det Norske Veritas (DNV)
Lloyd's Register (LR)
Germanischer Lloyd (GL)
Bureau Veritas (BV)
Registro Italiano Navale (RINA)
American Bureau of Shipping (ABS)
Other approvals on request



Available on stock CABLE GLANDS: see page 404 up to 416 of catalogue.

GAALSHIP® DATA HF 350 A

Armoured, halogen-free flexible data cable 350 V



ELETTROTEK KABEL® GAALSHIP® DATA HF 350 A



Part no.	No. of cores x cross section n x mm ²	Outer-Ø ca.mm ± 10%	Copper weight kg/km	Cable weight approx. kg/km	AWG no.*)
11020C54020M01	2 x 0,14	4,2	13	26	26
11020C54030M01	3 x 0,14	4,5	14,4	31	26
11020C54040M01	4 x 0,14	4,8	19,3	37	26
11020C54050M01	5 x 0,14	5,1	20,7	41	26
11020C54060M01	6 x 0,14	5,5	22,2	46	26
11020C54070M01	7 x 0,14	5,5	23,5	46	26
11020C54080M01	8 x 0,14	6,0	28,4	58	26
11020C54120M01	12 x 0,14	6,5	35,8	72	26
11020C54160M01	16 x 0,14	7,5	43	86	26
11020C54020M02	2 x 0,25	4,5	18,6	31	24
11020C54030M02	3 x 0,25	4,8	21,1	35	24
11020C54040M02	4 x 0,25	5,2	23,6	40	24
11020C54050M02	5 x 0,25	5,5	27,9	50	24
11020C54060M02	6 x 0,25	6,0	30,5	55	24
11020C54070M02	7 x 0,25	6,0	32,9	60	24
11020C54080M02	8 x 0,25	6,5	38,8	70	24
11020C54120M02	12 x 0,25	7,6	50,3	90	24
11020C54160M02	16 x 0,25	8,5	62,2	120	24
11020C54020M03	2 x 0,34	5,0	20,5	35	22
11020C54030M03	3 x 0,34	5,2	23,8	40	22
11020C54040M03	4 x 0,34	5,6	29	50	22
11020C54050M03	5 x 0,34	6,0	32,4	60	22
11020C54060M03	6 x 0,34	6,5	39,1	70	22
11020C54070M03	7 x 0,34	6,5	42,4	77	22
11020C54080M03	8 x 0,34	7,5	47,6	90	22
11020C54120M03	12 x 0,34	8,5	65,3	120	22
11020C54160M03	16 x 0,34	9,5	81,2	150	22
11020C54020M05	2 x 0,5	5,0	23,7	45	20
11020C54030M05	3 x 0,5	5,5	30,3	50	20
11020C54040M05	4 x 0,5	6,0	35,3	65	20
11020C54050M05	5 x 0,5	6,5	43,5	75	20
11020C54060M05	6 x 0,5	7,0	50,1	85	20
11020C54070M05	7 x 0,5	7,0	54,9	90	20
11020C54080M05	8 x 0,5	8,5	62,2	115	20
11020C54120M05	12 x 0,5	9,6	86,6	150	20
11020C54160M05	16 x 0,5	10,9	124,5	200	20
11020C54020M07	2 x 0,75	5,5	30,4	50	19
11020C54030M07	3 x 0,75	6,0	39,2	65	19
11020C54040M07	4 x 0,75	6,5	48,4	80	19
11020C54050M07	5 x 0,75	7,5	57,5	95	19
11020C54060M07	6 x 0,75	8,0	66,9	105	19
11020C54070M07	7 x 0,75	8,0	74,1	115	19
11020C54080M07	8 x 0,75	9,5	83,9	140	19
11020C54120M07	12 x 0,75	11,0	134,2	195	19
11020C54160M07	16 x 0,75	12,0	169,6	250	19

Other dimensions and colors available on request.

GAALSHIP® DATA HF 350 A TP

Armoured, halogen-free flexible paired data cable 350 V



ELETTROTEK KABEL® GAALSHIP® DATA HF 350 A TP

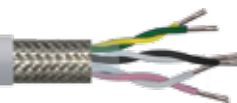

Construction:

Conductor:	flexible tinned copper conductor Cl. 5, acc to IEC 60228, DIN VDE 0295
Insulation:	Halogen-free compound
Colour core:	acc. to DIN 47100
Stranding:	pairwise, pairs in layer
Wrapping:	PETP foil
Armouring:	tinned copper braiding
Outer sheath:	grey (RAL 7001) Halogen-free compound

Technical data:

Nominal voltage:	max. 350 V
Test voltage:	1500 V
Temperature range:	
<i>Fixed laying:</i>	-40 up to +90 °C
<i>Flexible application:</i>	-30 up to +90 °C
Min. bending radius:	
<i>Fixed laying:</i>	5 x d
<i>Flexible application:</i>	10 x d

Resistance:



Self-extinguishing, flame retardant and no flame propagation acc. to:

DIN EN 60332-1-2,
IEC 60332-1-2,
DIN EN 60332-3-22,
IEC 60332-3-22



Halogen free acc. to:

EN 50267-2-1,
IEC 60754-1



Corrosiveness of conflagration gases acc. to:

DIN EN 50267-2-2,
IEC 60754-2



Smoke density acc. to:

EN 61034,
IEC 61034

Features:

On request class 2

We have possibility to provide the following Certifications on request:

Det Norske Veritas (DNV)
Lloyd's Register (LR)
Germanischer Lloyd (GL)
Bureau Veritas (BV)
Registro Italiano Navale (RINA)
American Bureau of Shipping (ABS)
Other approvals on request



**Available on stock CABLE GLANDS:
see page 404 up to 416 of catalogue.**

GAALSHIP® DATA HF 350 A TP

Armoured, halogen-free flexible paired data cable 350V



ELETTROTEK KABEL® GAALSHIP® DATA HF 350 A TP

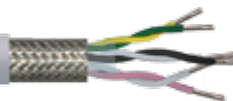

Part no.	No. of cores x cross section n x mm ²	Outer-Ø ca.mm ± 10%	Copper weight kg/km	Cable weight approx. kg/km	AWG no.*)
11030C54022M01	2 x 2 x 0,14	5,5	19,5	40	26
11030C54032M01	3 x 2 x 0,14	6,0	21,4	45	26
11030C54042M01	4 x 2 x 0,14	7,0	30,4	60	26
11030C54052M01	5 x 2 x 0,14	7,5	34,9	70	26
11030C54062M01	6 x 2 x 0,14	7,5	39,8	75	26
11030C54072M01	8 x 2 x 0,14	9,0	47,6	100	26
11030C54082M01	10 x 2 x 0,14	9,5	55,9	115	26
11030C54122M01	12 x 2 x 0,14	10,5	79,9	145	26
11030C54182M01	18 x 2 x 0,14	12,5	102,9	200	26
11030C54022M02	2 x 2 x 0,25	6,0	25,7	45	24
11030C54032M02	3 x 2 x 0,25	6,5	32,1	60	24
11030C54042M02	4 x 2 x 0,25	7,5	40,6	70	24
11030C54052M02	5 x 2 x 0,25	9,0	50,1	95	24
11030C54062M02	6 x 2 x 0,25	9,0	54,9	105	24
11030C54082M02	8 x 2 x 0,25	9,2	67,4	120	24
11030C54102M02	10 x 2 x 0,25	10,5	95,7	155	24
11030C54122M02	12 x 2 x 0,25	11,5	111,9	180	24
11030C54182M02	18 x 2 x 0,25	14,0	171,9	270	24
11030C54022M03	2 x 2 x 0,34	6,5	30,7	55	22
11030C54032M03	3 x 2 x 0,34	7,0	40,9	70	22
11030C54042M03	4 x 2 x 0,34	9,0	52,3	100	22
11030C54052M03	5 x 2 x 0,34	9,5	61,6	115	22
11030C54062M03	6 x 2 x 0,34	9,5	68,2	130	22
11030C54082M03	8 x 2 x 0,34	11,0	100	165	22
11030C54102M03	10 x 2 x 0,34	12,0	119,7	195	22
11030C54122M03	12 x 2 x 0,34	13,5	138,2	140	22
11030C54182M03	18 x 2 x 0,34	16,0	215,3	360	22
11030C54022M05	2 x 2 x 0,5	7,0	40,5	70	20
11030C54032M05	3 x 2 x 0,5	8,0	52,5	90	20
11030C54042M05	4 x 2 x 0,5	9,5	67,4	120	20
11030C54052M05	5 x 2 x 0,5	10,5	95,6	155	20
11030C54062M05	6 x 2 x 0,5	11,0	105,4	170	20
11030C54082M05	8 x 2 x 0,5	12,0	131,3	210	20
11030C54102M05	10 x 2 x 0,5	13,5	155,9	260	20
11030C54122M05	12 x 2 x 0,5	15	212,6	320	20
11030C54182M05	18 x 2 x 0,5	17,5	283,5	450	20
11030C54022M07	2 x 2 x 0,75	8	52,5	90	19
11030C54032M07	3 x 2 x 0,75	9	69,5	115	19
11030C54042M07	4 x 2 x 0,75	10,5	105,3	155	19
11030C54052M07	5 x 2 x 0,75	11,5	126,5	185	19
11030C54062M07	6 x 2 x 0,75	12,5	141	220	19
11030C54082M07	8 x 2 x 0,75	14	200,7	285	19
11030C54102M07	10 x 2 x 0,75	15	241,6	340	19
11030C54122M07	12 x 2 x 0,75	17	283,2	410	19
11030C54182M07	18 x 2 x 0,75	19,5	384	555	19

Other dimensions and colors available on request.

GAALSHIP® HF 500 FRNC

Halogen-free, flexible control cable 300/500 V





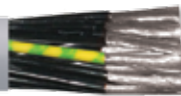

ELETTROTEK KABEL® GAALSHIP® HF 500 FRNC



Construction:

Conductor:	flexible tinned copper conductor Cl. 5, acc to IEC 60228, DIN VDE 0295
Insulation:	Halogen-free compound
Colour core:	black conductors with consecutive numbers acc. to EN 50334 green-yellow earth wire from 3 conductor
Stranding:	in layer
Outer sheath:	grey (RAL 7001) Halogen-free compound

Resistance:

	Self-extinguishing, flame retardant and no flame propagation acc. to: DIN EN 60332-1-2, IEC 60332-1-2, DIN EN 60332-3-22, IEC 60332-3-22
	Halogen free acc. to: EN 50267-2-1, IEC 60754-1
	Corrosiveness of conflagration gases acc. to: DIN EN 50267-2-2, IEC 60754-2
	Smoke density acc. to: EN 61034, IEC 61034

Technical data:

Nominal voltage:	300/500 V
Test voltage:	2000 V
Temperature range:	
<i>Fixed laying:</i>	-40 up to +90 °C
<i>Flexible application:</i>	-30 up to +90 °C
Min. bending radius:	
<i>Fixed laying:</i>	5 x d
<i>Flexible application:</i>	10 x d

Features:

Test voltage acc.to: DIN VDE 0281 part. 2 + HD 21.2
On request class 2

We have possibility to provide the following Certifications on request:

Det Norske Veritas (DNV)
Lloyd's Register (LR)
Germanischer Lloyd (GL)
Bureau Veritas (BV)
Registro Italiano Navale (RINA)
American Bureau of Shipping (ABS)
Other approvals on request



**Available on stock CABLE GLANDS:
see page 404 up to 416 of catalogue.**

GAALSHIP® MARINE CABLES

GAALSHIP® HF 500 FRNC

Halogen-free, flexible control cable 300/500 V



ELETTROTEK KABEL® GAALSHIP® HF 500 FRNC

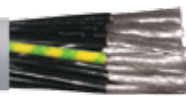

Part no.	No. of cores x cross section n x mm ²	Outer-Ø ca.mm ± 10%	Copper weight kg/km	Cable weight approx. kg/km	AWG no.*)
12010D51020M05	2 x 0,5	5,5	9,6	40	20
12010D50031M05	3 G 0,5	5,7	14,6	50	20
12010D50041M05	4 G 0,5	6,1	19,2	60	20
12010D50051M05	5 G 0,5	6,7	24	70	20
12010D50071M05	7 G 0,5	7,7	33,6	90	20
12010D50121M05	12 G 0,5	9,7	57,6	150	20
12010D50181M05	18 G 0,5	11,6	86,4	210	20
12010D51020M07	2 G 0,75	5,9	14,4	50	19
12010D50031M07	3 G 0,75	6,1	21,6	60	19
12010D50041M07	4 G 0,75	6,8	28,8	75	19
12010D50051M07	5 G 0,75	7,6	36	90	19
12010D50071M07	7 G 0,75	8,2	50,4	115	19
12010D50121M07	12 G 0,75	11,1	86,4	190	19
12010D50181M07	18 G 0,75	13,0	129,6	270	19
12010D51020M10	2 x 1	6,1	19,2	60	18
12010D50031M10	3 G 1	6,5	28,8	70	18
12010D50041M10	4 G 1	7,2	38,4	85	18
12010D50051M10	5 G 1	8,0	48	106	18
12010D50071M10	7 G 1	8,5	67,2	130	18
12010D50121M10	12 G 1	11,5	115,2	215	18
12010D50181M10	18 G 1	13,5	172,8	320	18
12010D51020M15	2 x 1,5	6,5	28,8	75	16
12010D50031M15	3 G 1,5	7,0	43,2	90	16
12010D50041M15	4 G 1,5	8,0	57,6	110	16
12010D50051M15	5 G 1,5	8,5	72	135	16
12010D50071M15	7 G 1,5	9,5	100,8	175	16
12010D50121M15	12 G 1,5	12,5	172,8	290	16
12010D50181M15	18 G 1,5	15,5	259,2	425	16
12010D51020M25	2 x 2,5	8,0	48	110	14
12010D50031M25	3 G 2,5	8,5	72	140	14
12010D50041M25	4 G 2,5	9,5	96	170	14
12010D50051M25	5 G 2,5	10,5	120	210	14
12010D50071M25	7 G 2,5	11,5	168	270	14
12010D50121M25	12 G 2,5	15,5	288	450	14
12010D50181M25	18 G 2,5	19,0	432	672	14

Other dimensions and colors available on request.

GAALSHIP® HF 500 A FRNC

Armoured, halogen-free, flexible control cable 300/500 V



ELETTROTEK KABEL® GAALFLEX® GAALSHIP HF 500 A FRNC

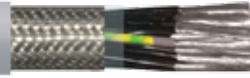

Construction:

Conductor:	flexible tinned copper conductor Cl. 5, acc to IEC 60228, DIN VDE 0295
Insulation:	Halogen-free compound
Colour core:	black conductors with consecutive numbers acc. to EN 50334 green-yellow earth wire from 3 conductor
Stranding:	in layer
Wrapping:	PETP foil
Armouring:	tinned copper braid
Outer sheath:	grey (RAL 7001) Halogen-free compound

Technical data:

Nominal voltage:	300/500 V
Test voltage:	2000 V
Temperature range:	
<i>Fixed laying:</i>	-40 up to +90 °C
<i>Flexible application:</i>	-30 up to +90 °C
Min. bending radius:	
<i>Fixed laying:</i>	5 x d
<i>Flexible application:</i>	10 x d

Resistance:



Self-extinguishing, flame retardant and no flame propagation acc. to:

DIN EN 60332-1-2,
IEC 60332-1-2,
DIN EN 60332-3-22,
IEC 60332-3-22



Halogen free acc. to:

EN 50267-2-1,
IEC 60754-1



Corrosiveness of conflagration gases acc. to:

DIN EN 50267-2-2,
IEC 60754-2



Smoke density acc. to:

EN 61034,
IEC 61034

Features:

Test voltage acc.to: DIN VDE 0281 part. 2 + HD 21.2

On request class 2

We have possibility to provide the following Certifications on request:

Det Norske Veritas (DNV)

Lloyd's Register (LR)

Germanischer Lloyd (GL)

Bureau Veritas (BV)

Registro Italiano Navale (RINA)

American Bureau of Shipping (ABS)

Other approvals on request



**Available on stock CABLE GLANDS:
see page 404 up to 416 of catalogue.**

GAALSHIP® MARINE CABLES

GAALSHIP® HF 500 A FRNC

Armoured, halogen-free, flexible control cable 300/500 V



ELETTROTEK KABEL® GAALFLEX® GAALSHIP HF 500 A FRNC

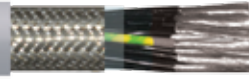

Part no.	No. of cores x cross section n x mm ²	Outer-Ø ca.mm ± 10%	Copper weight kg/km	Cable weight approx. kg/km	AWG no.)*
12020D51020M05	2 x 0,5	6,0	25,5	51	20
12020D50031M05	3 G 0,5	6,2	30,4	60	20
12020D50041M05	4 G 0,5	6,5	36,9	70	20
12020D50051M05	5 G 0,5	7,0	43,6	80	20
12020D50071M05	7 G 0,5	8,0	55	105	20
12020D50121M05	12 G 0,5	10,0	86,7	165	20
12020D50181M05	18 G 0,5	12,5	140,7	250	20
12020D51020M07	2 x 0,75	6,0	30,6	60	19
12020D50031M07	3 G 0,75	6,5	39,3	65	19
12020D50041M07	4 G 0,75	7,5	48,5	85	19
12020D50051M07	5 G 0,75	8,0	57,5	100	19
12020D50071M07	7 G 0,75	8,5	74,2	125	19
12020D50121M07	12 G 0,75	11,5	140,4	220	19
12020D50181M07	18 G 0,75	13,5	189,4	310	19
12020D51020M10	2 x 1	6,5	36,9	67	18
12020D50031M10	3 G 1	7,0	48,3	78	18
12020D50041M10	4 G 1	7,7	69,7	95	18
12020D50051M10	5 x 1	8,5	71,7	120	18
12020D50071M10	7 G 1	9,1	93,4	147	18
12020D50121M10	12 G 1	12,0	169,4	252	18
12020D50181M10	18 G 1	14,5	258,5	380	18
12020D51020M15	2 x 1,5	7,5	48,5	81	16
12020D50031M15	3 G 1,5	7,8	64,5	100	16
12020D50041M15	4 G 1,5	8,5	81,3	122	16
12020D50051M15	5 G 1,5	9,5	98,2	151	16
12020D50071M15	7 G 1,5	10,0	129,9	190	16
12020D50121M15	12 G 1,5	13,5	232,5	325	16
12020D50181M15	18 G 1,5	16,5	357,1	490	16
12020D51020M25	2 x 2,5	8,5	71,8	113	14
12020D50031M25	3 G 2,5	9,5	98,2	146	14
12020D50041M25	4 G 2,5	10,0	125,1	183	14
12020D50051M25	5 G 2,5	11,5	167,9	240	14
12020D50071M25	7 G 2,5	12,5	222,4	300	14
12020D50121M25	12 G 2,5	17,0	386,4	510	14
12020D50181M25	18 G 2,5	20,0	556,3	750	14

Other dimensions and colors available on request.

GAALSHIP® N07G9-K

Single-core, halogen-free, flexible control cable 450/750 V



ELETTROTEK KABEL® GAALSHIP® N07G9-K

Construction:

Conductor: flexible tinned copper conductor Cl. 5, acc to IEC 60228, DIN VDE 0295

Insulation: black (RAL 9005), special Rubber type G9, On request: Green/yellow, blue, brown, grey, red white

Resistance:



Self-extinguishing, flame retardant and no flame propagation acc. to:

DIN EN 60332-1-2,
IEC 60332-1-2,
DIN EN 60332-3-22,
IEC 60332-3-22



Halogen free acc. to:

EN 50267-2-1,
IEC 60754-1



Corrosiveness of conflagration gases acc. to:

DIN EN 50267-2-2,
IEC 60754-2



Smoke density acc. to:

EN 61034,
IEC 61034

Technical data:

Nominal voltage: 450/750 V
Test voltage: 2500 V
Temperature range: -15 up to +90 °C
Short circuit temperature: + 250°C
Min. bending radius: 4 x d

Features:

Acc. to CEI UNEL 35368

We have possibility to provide the following Certifications on request:

Registro Italiano Navale (RINA)



Available on stock CABLE GLANDS: see page 404 up to 416 of catalogue.

Part no.	No. of cores x cross section n x mm ²	Outer-Ø ca.mm ± 10%	Copper weight kg/km	Cable weight approx. kg/km	AWG no.*)
12030E01010M15	1x1,5	3,2	14,4	25	16
12030E01010M25	1x2,5	4	24	35	14
12030E01010M40	1x4	4,3	38,4	50	12
12030E01010M60	1x6	5,1	57,6	70	10
12030E01010M61	1x10	6,4	96	115	8
12030E01010M62	1x16	7,5	153,6	170	6
12030E01010M63	1x25	9,3	240	260	4
12030E01010M64	1x35	10,4	336	360	2
12030E01010M65	1x50	12,2	480	510	1
12030E01010M66	1x70	13,7	672	720	2/0
12030E01010M67	1x95	15,5	912	930	3/0
12030E01010M68	1x120	17,8	1152	1220	4/0
12030E01010M69	1x150	20,0	1440	1510	250 MCM
12030E01010M70	1x185	22,3	1776	1820	350 MCM
12030E01010M71	1x240	25,4	2304	2350	450 MCM

Other dimensions and colors available on request.

GAALSHIP® HF 1000

Power and control cable 0,6/1 kV



Construction:

Conductor:	red copper conductor Cl. 2 up to 35 mm ² Cl. 5 from 50 mm ² , acc. to IEC 60228
Insulation:	XLPE halogen free compound acc. to IEC 60092-351, Thickness acc. to IEC 60092-353
Fillers (if any):	halogen free compound
Outer sheath:	black (RAL 9005), Halogen free thermoplastic compound type SHF1, acc. to IEC 60092-359, Thickness acc. to IEC 60092-353

Technical data:

Nominal voltage:	U ₀ /U 0,6/1 kV (1,2 kV)
Temperature range:	-25°C up to +90°C
<i>Installation temp.:</i>	-5°C
Short circuit temperature:	+250°C
Min. bending radius:	
<i>Fixed laying:</i>	5 x d
<i>Flexible application:</i>	10 x d

Resistance:



Flame and fire retardant acc. to:
IEC 60332-1-2,
IEC 60332-3-22



Halogen free acc. to:
IEC 60754-1/2



Smoke emission properties acc. to:
IEC 61034-1/2

Features:

Sheathing materials acc. to: IEC 60092-359
Insulating materials acc. to: IEC 60092-351
Design guidelines acc. to: IEC 60092-350/353
Choice and installation of electric cables acc. to: IEC 60092-352
on request class 5 for sections up to 35 mm²
on request tinned copper conductor

We have possibility to provide the following Certifications on request:

Det Norske Veritas (DNV)
Lloyd's Register (LR)
Germanischer Lloyd (GL)
Bureau Veritas (BV)
Registro Italiano Navale (RINA)
American Bureau of Shipping (ABS)
Other approvals on request



Available on stock CABLE GLANDS:
see page 404 up to 416 of catalogue.

GAALSHIP® MARINE CABLES

GAALSHIP® HF 1000

Power and control cable 0,6/1 kV



ELETTROTEK KABEL® GAALSHIP® HF 1000

Part no.	No. of cores x cross section n x mm ²	Outer-Ø ca.mm ± 10%	Copper weight kg/km	Cable weight approx. kg/km	AWG no.*)
12040G7L010M15	1x1,5	5,5	14	50	16
12040G7L010M25	1x2,5	5,8	21	60	14
12040G7L010M40	1x4	6,4	35	80	12
12040G7L010M60	1x6	6,9	51	100	10
12040G7L010M61	1x10	7,9	85	140	8
12040G7L010M62	1x16	8,9	132	195	6
12040G7L010M63	1x25	10,5	215	295	4
12040G7L010M64	1x35	11,8	299	390	2
12041G7L010M65	1x50	16,8	420	660	1
12041G7L010M66	1x70	18,8	591	880	2/0
12041G7L010M67	1x95	21,4	802	1150	3/0
12041G7L010M68	1x120	22,8	1044	1430	4/0
12041G7L010M69	1x150	24,8	1292	1750	250 MCM
12041G7L010M70	1x185	27,8	1604	2150	350 MCM
12041G7L010M71	1x240	30,8	2123	2730	450 MCM
12041G7L010M72	1x300	33,3	2626	3320	550 MCM
12040G73020M15	2x1,5	8,7	28	120	16
12040G73020M25	2x2,5	9,5	43	140	14
12040G73020M40	2x4	10,5	69	190	12
12040G73020M60	2x6	11,9	102	250	10
12040G73020M61	2x10	13,5	171	350	8
12040G73020M62	2x16	15,5	272	490	6
12040G73020M63	2x25	18,9	457	750	4
12040G73020M64	2x35	23,8	624	1230	2
12041G73030M15	3x1,5	9,4	42	130	16
12040G73030M25	3x2,5	10,2	65	160	14
12040GE2031M25	3G2,5	10,2	65	160	14
12040G73030M40	3x4	11,4	105	230	12
12040G73030M60	3x6	12,8	154	300	10
12040G73030M61	3x10	14,7	257	440	8
12040G73030M62	3x16	16,5	409	630	6
12040G73030M63	3x25	20,3	648	980	4
12040G73030M64	3x35	23,4	899	1250	2
12041G73030M65	3x50	27,9	1264	1740	1
12041G73030M66	3x70	32,4	1778	2390	2/0
12041G73030M67	3x95	36,8	2417	3220	3/0
12041G73030M68	3x120	41,5	3148	4130	4/0
12041G73030M69	3x150	45,5	3896	5100	250 MCM
12041G73030M70	3x185	51,8	4838	6390	350 MCM
12041G73030M71	3x240	57,8	6402	8330	450 MCM
12040G73040M15	4x1,5	10,2	56	160	16
12040GE2041M15	4G1,5	10,2	56	160	16
12040G73040M25	4x2,5	11,3	86	200	14
12040GE2041M25	4G2,5	11,3	86	200	14
12040G73040M40	4x4	12,5	140	280	12
12040G73040M60	4x6	13,9	206	370	10
12040G73040M61	4x10	15,9	342	550	8
12040G73040M62	4x16	18,5	545	820	6
12040G73040M63	4x25	22,4	863	1250	4
12040G73040M64	4x35	25,8	1200	1570	2
12041G73040M65	4x50	30,8	1686	1686	1
12041G73040M66	4x70	35,7	2373	2372	2/0
12041G73040M67	4x95	41,4	3226	3225	3/0
12041G73040M68	4x120	45,8	4202	4201	4/0
12041G73040M69	4x150	50,3	5760	6570	250 MCM
12041G73040M70	4x185	57,8	7104	8220	350 MCM
12040G73050M40	5x4	13,5	192	340	12
12040G73050M60	5x6	15,3	258	460	10
12040G73050M61	5x10	17,7	429	690	8
12040G73050M62	5x16	20,1	768	1010	6
12040G73050M63	5x25	24,8	1200	1550	4
12040G73050M64	5x35	30,8	1504	2350	2
12040G71040M10	4x1	9,3	37	130	18

GAALSHIP® MARINE CABLES

GAALSHIP® HF 1000

Power and control cable 0,6/1 kV



Part no.	No. of cores x cross section n x mm ²	Outer-Ø ca.mm ± 10%	Copper weight kg/km	Cable weight approx. kg/km	AWG no.*)
12040G71050M10	5x1	10,2	46	150	18
12040GG1070M10	7x1	10,9	64	180	18
12040GG1100M10	10x1	13,9	91	240	18
12040GG1120M10	12x1	14,3	115,2	280	18
12040GG1140M10	14x1	15,4	128	320	18
12040GG1160M10	16x1	16,3	146	350	18
12040GG1190M10	19x1	16,8	174	400	18
12040GG1240M10	24x1	19,8	216	500	18
12040GG1270M10	27x1	20,4	259,2	540	18
12040GG1300M10	30x1	21,5	274	600	18
12040GG1370M10	37x1	22,8	355,2	710	18
12040G73050M15	5x1,5	10,9	70	190	16
12040GG1070M15	7x1,5	12,1	98	230	16
12040GG1100M15	10x1,5	15,4	150	320	16
12040GG1120M15	12x1,5	15,8	140	360	16
12040GG1140M15	14x1,5	16,8	168	400	16
12040GG1160M15	16x1,5	17,9	195	470	16
12040GG1190M15	19x1,5	18,8	266	530	16
12040GG1240M15	24x1,5	21,8	336	660	16
12040GG1270M15	27x1,5	22,4	368	720	16
12040GG1300M15	30x1,5	23,3	419	790	16
12040GG1370M15	37x1,5	25,4	516	950	16
12040G73050M25	5x2,5	12,1	110	250	16
12040GG1070M25	7x2,5	13,5	150	300	14
12040GG1100M25	10x2,5	16,8	240	420	14
12040GG1120M25	12x2,5	17,8	288	490	14
12040GG1140M25	14x2,5	18,8	336	560	14
12040GG1160M25	16x2,5	19,8	384	630	14
12040GG1190M25	19x2,5	20,9	456	720	14
12040GG1240M25	24x2,5	24,8	576	900	14
12040GG1270M25	27x2,5	25,3	648	1000	14
12040GG1300M25	30x2,5	26,3	720	1100	14
12040GG1370M25	37x2,5	28,3	888	1320	14

Other dimensions and colors available on request.

GAALSHIP® HF 1000 A

Armoured, power and control cable 0,6/1 kV



Construction:

Conductor:	red copper conductor Cl. 2 up to 35 mm ² Cl. 5 from 50 mm ² , acc. to IEC 60228
Insulation:	XLPE halogen free compound acc. to IEC 60092-351, Thickness acc. to IEC 60092-353
Fillers (if any):	halogen free compound
Inner sheath:	halogen free compound or synthetic tape
Armour:	red copper wires braid acc. to IEC 60092-350
Outer sheath:	black (RAL 9005), Halogen free thermoplastic compound type SHF1, acc. to IEC 60092-359, Thickness acc. to IEC 60092-353

Technical data:

Nominal voltage:	U ₀ /U 0,6/1 kV (1,2 kV)
Temperature range:	-25°C up to +90°C
<i>Installation temp.:</i>	-5°C
Short circuit temperature:	+250°C
Min. bending radius:	6 x d

Resistance:



Flame and fire retardant acc. to:
IEC 60332-1-2,
IEC 60332-3-22



Halogen free acc. to:
IEC 60754-1/2



Smoke emission properties acc. to:
IEC 61034-1/2

Features:

Sheathing materials acc. to: IEC 60092-359
Insulating materials acc. to: IEC 60092-351
Design guidelines acc. to: IEC 60092-350/353
Choice and installation of electric cables acc. to: IEC 60092-352
on request class 5 for sections up to 35 mm²
on request tinned copper conductor
on request tinned copper wire braid armour

We have possibility to provide the following Certifications on request:

- Det Norske Veritas (DNV)
- Lloyd's Register (LR)
- Germanischer Lloyd (GL)
- Bureau Veritas (BV)
- Registro Italiano Navale (RINA)
- American Bureau of Shipping (ABS)
- Other approvals on request



Available on stock CABLE GLANDS:
see page 404 up to 416 of catalogue.

GAALSHIP® MARINE CABLES

GAALSHIP® HF 1000 A

Armoured, power and control cable 0,6/1 kV



ELETTROTEK KABEL® GAALSHIP® HF 1000 A

Part no.	No. of cores x cross section n x mm ²	Ø under armour ca.mm ± 10%	Outer-Ø ca.mm ± 10%	Copper weight kg/km	Cable weight approx. kg/km	AWG no.*)
12050G7L010M60	1x6	4,9	7,9	77	135	10
12050G7L010M61	1x10	5,6	9,2	115	185	8
12050G7L010M62	1x16	6,6	9,9	171	250	6
12050G7L010M63	1x25	8	11,8	263	360	4
12050G7L010M64	1x35	9	12,7	344	465	2
12051G7L010M65	1x50	14,4	18,8	536	850	1
12051G7L010M66	1x70	16,4	20,8	724	1100	2/0
12051G7L010M67	1x95	18,5	23,5	951	1370	3/0
12051G7L010M68	1x120	20,4	25,8	1198	1690	4/0
12051G7L010M69	1x150	22	27,4	1463	2070	250 MCM
12051G7L010M70	1x185	25	29,8	1796	2500	350 MCM
12051G7L010M71	1x240	27,5	32,8	2334	3120	450 MCM
12051G7L010M72	1x300	30	35,5	2857	3740	550 MCM
12050G73020M15	2x1,5	6,3	9,9	2851	135	16
12050G73020M25	2x2,5	7	10,5	79	160	14
12050G73020M40	2x4	8	11,7	107	210	12
12050G73020M60	2x6	9,3	12,9	143	260	10
12050G73020M61	2x10	10,8	15,2	217	390	8
12050G73020M62	2x16	12,5	17,4	326	530	6
12050G73020M63	2x25	15,8	20,8	579	760	4
12050G73020M64	2x35	21,4	26,5	773	1500	2
12050G73020M65	3x1,5	6,8	10,2	79	160	16
12050GE2021M65	3G1,5	6,8	10,2	79	160	16
12050G73030M25	3x2,5	7,7	11,2	102	200	14
12050GE2031M25	3G2,5	7,7	11,2	102	200	14
12050G73030M40	3x4	8,6	12,5	148	260	12
12050G73030M60	3x6	10	13,5	206	330	10
12050G73030M61	3x10	11,7	16,4	341	500	8
12050G73030M62	3x16	13,5	18,3	513	700	6
12050G73030M63	3x25	17	21,8	782	1030	4
12050G73030M64	3x35	19,7	24,8	1120	1450	2
12051G73030M65	3x50	23,8	29,4	1440	1960	1
12051G73030M66	3x70	28	33,8	1988	2670	2/0
12051G73030M67	3x95	32,5	38,4	2661	3520	3/0
12051G73030M68	3x120	36,7	43,4	3511	4600	4/0
12051G73030M69	3x150	40,4	47,4	4315	5630	250 MCM
12051G73030M70	3x185	46,5	53,8	5332	6970	350 MCM
12051G73030M71	3x240	52	59,5	6913	9950	450 MCM
12050G73040M15	4x1,5	7,5	10,9	96	200	16
12050GE2041M15	4G1,5	7,5	10,9	96	200	16
12050G73040M25	4x2,5	8,5	12,1	131	240	14
12050GE2041M25	4G2,5	8,5	12,1	131	240	14
12050G73040M40	4x4	9,8	13,3	191	320	12
12050G73040M60	4x6	11,1	15,4	290	450	10
12050G73040M61	4x10	13	17,8	442	630	8
12050G73040M62	4x16	15,2	19,8	658	890	6
12050G73040M63	4x25	19	23,8	1014	1320	4
12050G73040M64	4x35	22	27,4	1456	1790	2
12051G73040M65	4x50	26,5	32,3	1891	2470	1
12051G73040M66	4x70	31,4	37,4	2609	3370	2/0
12051G73040M67	4x95	36,5	42,8	3586	4570	3/0
12051G73040M68	4x120	41	47,8	4622	5800	4/0
12051G73040M69	4x150	45	52,5	6034	7120	250 MCM
12051G73040M70	4x185	52	59,8	7531	8900	350 MCM
12050G73050M15	5x1,5	8,5	12,1	111	230	16
12050G73050M25	5x2,5	9,5	13,1	158	300	14
12050G73050M40	5x4	10,8	15,1	240	425	12
12050G73050M60	5x6	12,5	16,8	300	540	10
12050G73050M61	5x10	14,7	19,5	509	770	8
12050G73050M62	5x16	16,8	21,8	814	1100	6
12050G73050M63	5x25	21,4	26,5	1272	1630	4
12050G73050M64	5x35	27,5	32,8	1730	2800	2
12050G71040M10	4x1	6,8	10,3	74	160	18

GAALSHIP® MARINE CABLES

GAALSHIP® HF 1000 A

Armoured, power and control cable 0,6/1 kV



Part no.	No. of cores x cross section n x mm ²	Ø under armour ca.mm ± 10%	Outer-Ø ca.mm ± 10%	Copper weight kg/km	Cable weight approx. kg/km	AWG no.)*
12050G71050M10	5x1	7,7	11,2	-	180	18
12050GG1070M10	7x1	8,5	13,1	108	230	18
12050GG1100M10	10x1	11,2	15,4	181	350	18
12050GG1120M10	12x1	11,7	15,8	200	390	18
12050GG1140M10	14x1	12,4	16,8	217	420	18
12050GG1160M10	16x1	13,1	17,7	246	480	18
12050GG1190M10	19x1	14	18,3	284	530	18
12050GG1240M10	24x1	16,7	21,4	358	670	18
12050GG1270M10	27x1	17,2	21,8	-	700	18
12050GG1300M10	30x1	18	22,5	414	750	18
12050GG1370M10	37x1	19,5	24,3	-	890	18
12050GG1070M15	7x1,5	9,4	12,9	147	280	16
12050GG1100M15	10x1,5	12,4	16,7	239	430	16
12050GG1120M15	12x1,5	13	17,5	260	490	16
12050GG1140M15	14x1,5	13,7	18,5	-	530	16
12050GG1160M15	16x1,5	14,5	19,3	328	590	16
12050GG1190M15	19x1,5	15,5	20,3	393	670	16
12050GG1240M15	24x1,5	18,5	23,4	481	640	16
12050GG1270M15	27x1,5	19	23,7	523	900	16
12050GG1300M15	30x1,5	19,8	24,8	575	980	16
12050GG1370M15	37x1,5	21,5	26,8	679	1150	16
12050GG1070M25	7x2,5	10,5	14,7	237	400	14
12050GG1100M25	10x2,5	14	18,3	-	550	14
12050GG1120M25	12x2,5	14,5	19,4	-	610	14
12050GG1140M25	14x2,5	15,5	20,3	-	690	14
12050GG1160M25	16x2,5	16,5	21,4	-	770	14
12050GG1190M25	19x2,5	17,5	22,5	549	870	14
12050GG1240M25	24x2,5	21	26,3	-	1080	14
12050GG1270M25	27x2,5	21,5	26,8	-	1190	14
12050GG1300M25	30x2,5	22,3	27,4	-	1290	14
12050GG1370M25	37x2,5	24,4	29,8	-	1530	14

Other dimensions and colors available on request.

GAALSHIP® HF 1000 FR

Fire resistant power and control cable 0,6/1 kV



Construction:

Conductor:	red copper conductor Cl. 2 up to 35 mm ² Cl. 5 from 50 mm ² , acc. to IEC 60228
Insulation:	MICA glass tape + XLPE Halogen free compound acc.to IEC 60092-351, thickness acc. to IEC 60092-353
Fillers (If any):	halogen free compound
Wrapping:	halogen free compound or synthetic tape
Outer sheath:	black (RAL 9005), Halogen free thermoplastic compound type SHF1, acc. to IEC 60092-359, Thickness acc. to IEC 60092-353

Resistance:



Fire resistant acc. to:
IEC 60331



Flame and fire retardant acc. to:
IEC 60332-1-2,
IEC 60332-3-22



Halogen free acc. to:
IEC 60754-1/2



Smoke emission properties acc. to:
IEC 61034-1/2

Technical data:

Nominal voltage:	U ₀ /U 0,6/1 kV (1,2 kV)
Temperature range:	-25°C up to +90°C
Installation temp.:	-5°C
Short circuit temperature:	+250°C
Min. bending radius:	6 x d

Features:

Sheathing materials acc. to: IEC 60092-359
 Insulating materials acc. to: IEC 60092-351
 Design guidelines acc. to: IEC 60092-350/353
 Choice and installation of electric cables acc. to: IEC 60092-352
 on request class 5 for sections up to 35 mm²
 on request tinned copper conductor

We have possibility to provide the following Certifications on request:

Det Norske Veritas (DNV)
 Lloyd's Register (LR)
 Germanischer Lloyd (GL)
 Bureau Veritas (BV)
 Registro Italiano Navale (RINA)
 American Bureau of Shipping (ABS)
 Other approvals on request



Available on stock CABLE GLANDS:
see page 404 up to 416 of catalogue.

GAALSHIP® HF 1000 FR

Fire resistant power and control cable 0,6/1 kV



Part no.	No. of cores x cross section n x mm ²	Outer-Ø ca.mm ± 10%	Copper weight kg/km	Cable weight approx. kg/km	AWG no.*)
12060G7L010M15	1x1,5	6	14	60	16
12060G7L010M25	1x2,5	6,4	22	70	14
12060G7L010M40	1x4	6,9	35	90	12
12060G7L010M60	1x6	7,5	51	110	10
12060G7L010M61	1x10	8,5	85	150	8
12060G7L010M62	1x16	9,7	135	210	6
12060G7L010M63	1x25	11,2	219	310	4
12060G7L010M64	1x35	12,4	297	420	2
12061G7L010M65	1x50	17,4	419	680	1
12061G7L010M66	1x70	19,3	590	910	2/0
12061G7L010M67	1x95	21,8	801	1170	3/0
12061G7L010M68	1x120	23,8	1044	1450	4/0
12061G7L010M69	1x150	25,4	1292	1750	250 MCM
12061G7L010M70	1x185	28,7	1604	2150	350 MCM
12061G7L010M71	1x240	31,4	2120	2740	450 MCM
12061G7L010M72	1x300	34,3	2626	3330	550 MCM
12060G73020M15	2x1,5	9,9	28	140	16
12060G73020M25	2x2,5	10,7	43	160	14
12060G73020M40	2x4	11,9	70	220	12
12060G73020M60	2x6	13,1	102	270	10
12060G73020M61	2x10	14,9	171	380	8
12060G73020M62	2x16	16,8	272	530	6
12060G73020M63	2x25	20,3	431	800	4
12060G73020M64	2x35	25,4	624	1290	2
12060G73030M15	3x1,5	10,6	42	160	16
12060GE2031M15	3G1,5	10,6	42	160	16
12060G73030M25	3x2,5	11,3	65	190	14
12060GE2031M25	3G2,5	11,3	65	190	14
12060G73030M40	3x4	12,7	104	260	12
12060G73030M60	3x6	13,9	154	330	10
12060G73030M61	3x10	15,8	256	480	8
12060G73030M62	3x16	18,4	409	680	6
12060G73030M63	3x25	21,7	648	1030	4
12060G73030M64	3x35	24,8	899	1310	2
12061G73030M65	3x50	28,5	1263	1820	1
12061G73030M66	3x70	33,9	1778	2490	2/0
12061G73030M67	3x95	38,4	2417	3300	3/0
12061G73030M68	3x120	42,8	3148	4210	4/0
12061G73030M69	3x150	46,8	3896	5100	250 MCM
12061G73030M70	3x185	53,4	4838	6490	350 MCM
12061G73030M71	3x240	59,3	6402	8410	450 MCM
12060G73040M15	4x1,5	11,5	56	180	16
12060GE2041M15	4G1,5	11,5	56	180	16
12060G73040M25	4x2,5	12,6	86	240	14
12060GE2041M25	4x2,5	12,6	86	240	14
12060G73040M40	4x4	13,9	139	320	12
12060G73040M60	4x6	15,4	206	420	10
12060G73040M61	4x10	17,8	342	600	8
12060G73040M62	4x16	19,8	545	850	6
12060G73040M63	4x25	23,8	864	1300	4
12060G73040M64	4x35	27,3	1201	1670	2
12061G73040M65	4x50	31,8	1686	2300	1
12061G73040M66	4x70	37,3	2372	3180	2/0
12061G73040M67	4x95	42,4	3225	4210	3/0
12061G73040M68	4x120	47,4	4201	5420	4/0
12061G73040M69	4x150	51,8	5760	6640	250 MCM
12061G73040M70	4x185	59,4	7104	8340	350 MCM
12060G73050M15	5x1,5	12,5	65	230	16
12060G73050M25	5x2,5	13,9	107	280	14
12060G73050M40	5x4	15,1	192	390	12
12060G73050M60	5x6	17,4	288	500	10
12060G73050M61	5x10	19,4	480	730	8
12060G73050M62	5x16	21,8	768	1050	6
12060G73050M63	5x25	26,8	1200	1610	4

GAALSHIP® MARINE CABLES

GAALSHIP® HF 1000 FR

Fire resistant power and control cable 0,6/1 kV



ELETTROTEK KABEL® GAALSHIP® HF 1000 FR

Part no.	No. of cores x cross section n x mm ²	Outer-Ø ca.mm ± 10%	Copper weight kg/km	Cable weight approx. kg/km	AWG no.*)
12060G73050M64	5x35	32,5	1680	2440	2
12060G71040M10	4x1	10,7	36	150	18
12060G71050M10	5x1	11,7	48	180	18
12060GG1070M10	7x1	12,7	64	220	18
12060GG1100M10	10x1	16,5	91	300	18
12060GG1120M10	12x1	16,8	115,2	340	18
12060GG1140M10	14x1	17,7	128	380	18
12060GG1160M10	16x1	18,8	153,6	420	18
12060GG1190M10	19x1	19,8	173	480	18
12060GG1240M10	24x1	23,8	219	610	18
12060GG1270M10	27x1	24,4	247	660	18
12060GG1300M10	30x1	25,4	274	730	18
12060GG1370M10	37x1	27,3	355,2	870	18
12060GG1070M15	7x1,5	13,9	98	270	16
12060GG1100M15	10x1,5	17,8	140	370	16
12060GG1120M15	12x1,5	18,5	162	430	16
12060GG1140M15	14x1,5	19,3	196	480	16
12060GG1160M15	16x1,5	20,7	209	540	16
12060GG1190M15	19x1,5	21,8	266	620	16
12060GG1240M15	24x1,5	25,9	331	780	16
12060GG1270M15	27x1,5	26,3	420	850	16
12060GG1300M15	30x1,5	27,4	391	940	16
12060GG1370M15	37x1,5	29,3	482	1130	16
12060GG1070M25	7x2,5	15,1	149	350	14
12060GG1100M25	10x2,5	19,7	240	480	14
12060GG1120M25	12x2,5	20,7	275	550	14
12060GG1140M25	14x2,5	21,7	336	640	14
12060GG1160M25	16x2,5	22,7	384	710	14
12060GG1190M25	19x2,5	24,1	456	820	14
12060GG1240M25	24x2,5	28,7	576	1030	14
12060GG1270M25	27x2,5	29,2	648	1130	14
12060GG1300M25	30x2,5	30,0	720	1250	14
12060GG1370M25	37x2,5	32,5	888	1500	14

Other dimensions and colors available on request.

GAALSHIP® HF 1000 A FR

Armoured, fire resistant power and control cable 0,6/1 kV



ELETTROTEK KABEL® GAALSHIP® HF 1000 A FR

Construction:

Conductor:	red copper conductor Cl. 2 up to 35 mm ² Cl. 5 from 50 mm ² , acc. to IEC 60228
Insulation:	MICA glass tape + XLPE Halogen free compound acc.to IEC 60092-351, thickness acc. to IEC 60092-353
Fillers (if any):	halogen free compound
Inner sheath:	halogen free compound or synthetic tape
Armour:	red copper wires braid acc. to IEC 60092-350
Outer sheath:	black (RAL 9005), Halogen free thermoplastic compound type SHF1, acc. to IEC 60092-359, Thickness acc. to IEC 60092-353

Technical data:

Nominal voltage:	U ₀ /U 0,6/1 kV (1,2 kV)
Temperature range:	-25°C up to +90°C
Installation temp.:	-5°C
Short circuit temperature:	+250°C
Min. bending radius:	6 x d

Resistance:



Fire resistant acc. to:
IEC 60331



Flame and fire retardant acc. to:
IEC 60332-1-2,
IEC 60332-3-22



Halogen free acc. to:
IEC 60754-1/2



Smoke emission properties acc. to:
IEC 61034-1/2

Features:

Sheathing materials acc. to: IEC 60092-359
Insulating materials acc. to: IEC 60092-351
Design guidelines acc. to: IEC 60092-350/353
Choice and installation of electric cables acc. to: IEC 60092-352
on request class 5 for sections up to 35 mm²

on request tinned copper conductor
on request tinned copper wire braid armour

We have possibility to provide the following Certifications on request:

- Det Norske Veritas (DNV)
- Lloyd's Register (LR)
- Germanischer Lloyd (GL)
- Bureau Veritas (BV)
- Registro Italiano Navale (RINA)
- American Bureau of Shipping (ABS)
- Other approvals on request



**Available on stock CABLE GLANDS:
see page 404 up to 416 of catalogue.**

GAALSHIP® MARINE CABLES

GAALSHIP® HF 1000 A FR

Armoured, fire resistant power and control cable 0,6/1 kV



ELETTROTEK KABEL® GAALSHIP® HF 1000 A FR

Part no.	No. of cores x cross section n x mm ²	Ø under armour ca.mm ± 10%	Outer-Ø ca.mm ± 10%	Copper weight kg/km	Cable weight approx. kg/km	AWG no.*)
12070G7L010M60	1x6	7,7	10,8	77	230	10
12070G7L010M61	1x10	8,5	12,2	114	280	8
12070G7L010M62	1x16	9,4	12,9	170	350	6
12070G7L010M63	1x25	11	14,7	358	475	4
12070G7L010M64	1x35	12	15,8	401	650	2
12071G7L010M65	1x50	15	19,4	526	870	1
12071G7L010M66	1x70	17	21,6	713	1120	2/0
12071G7L010M67	1x95	19	23,8	939	1410	3/0
12071G7L010M68	1x120	21	25,8	1197	1720	4/0
12071G7L010M69	1x150	22,7	27,4	1456	2100	250 MCM
12071G7L010M70	1x185	25,5	30,8	1790	2520	350 MCM
12071G7L010M71	1x240	28	33,4	2328	3140	450 MCM
12071G7L010M72	1x300	30,7	36,4	2851	3750	550 MCM
12070G73020M15	2x1,5	7,8	11,2	55	300	16
12070G73020M25	2x2,5	8,5	12,2	80	350	14
12070G73020M40	2x4	9,5	13,1	114	400	12
12070G73020M60	2x6	10,8	14,3	149	470	10
12070G73020M61	2x10	12,4	16,8	254	670	8
12070G73020M62	2x16	14	18,8	372	850	6
12070G73020M63	2x25	17,5	22,4	551	1200	4
12070G73020M64	2x35	22,5	27,3	766	1610	2
12070G73030M15	3x1,5	8,4	11,7	73	310	16
12070GE2031M15	3G1,5	8,4	11,7	74	310	16
12070G73030M25	3x2,5	9,2	12,8	101	375	14
12070GE2031M25	3G2,5	9,2	12,8	101	375	14
12070G73030M40	3x4	10,3	13,9	145	450	12
12070G73030M60	3x6	11,5	15,8	206	600	10
12070G73030M61	3x10	13,3	17,9	345	780	8
12070G73030M62	3x16	15,2	19,7	511	1020	6
12070G73030M63	3x25	18,7	23,8	780	1450	4
12070G73030M64	3x35	21	26,4	1070	1940	2
12071G73030M65	3x50	25	30,4	1448	2560	1
12071G73030M66	3x70	29,5	34,8	1994	3370	2/0
12071G73030M67	3x95	34	40,3	2750	4470	3/0
12071G73030M68	3x120	38	44,2	3520	5580	4/0
12071G73030M69	3x150	41,7	48,8	4310	6780	250 MCM
12071G73030M70	3x185	47,9	55,4	5311	8400	350 MCM
12071G73030M71	3x240	53,3	60,9	6935	10600	450 MCM
12070G73040M15	4x1,5	9,3	12,8	93	360	16
12070GE2041M15	4G1,5	9,3	12,8	93	360	16
12070G73040M25	4x2,5	10,3	13,9	126	420	14
12070GE2041M25	4G2,5	10,3	13,9	126	420	14
12070G73040M40	4x4	11,5	15,8	186	580	12
12070G73040M60	4x6	13	17,4	298	700	10
12070G73040M61	4x10	15	19,3	442	920	8
12070G73040M62	4x16	16,9	21,8	653	1230	6
12070G73040M63	4x25	20,8	25,9	999	1750	4
12070G73040M64	4x35	23,5	28,7	1396	2320	2
12071G73040M65	4x50	28	33,3	1892	3150	1
12071G73040M66	4x70	32,8	38,9	2617	4180	2/0
12071G73040M67	4x95	40	44,3	3596	5550	3/0
12071G73040M68	4x120	42,5	49,2	4617	6920	4/0
12071G73040M69	4x150	46,5	53,9	6034	8480	250 MCM
12071G73040M70	4x185	53,5	61,4	7531	10500	350 MCM
12070G73050M15	5x1,5	10,4	13,8	111	420	16
12070G73050M25	5x2,5	11,5	15,7	157	550	14
12070G73050M40	5x4	12,8	17,5	240	670	12
12070G73050M60	5x6	14,5	18,7	300	830	10
12070G73050M61	5x10	16,5	21,5	509	1080	8

GAALSHIP® MARINE CABLES

GAALSHIP® HF 1000 A FR

Armoured, fire resistant power and control cable 0,6/1 kV



Part no.	No. of cores x cross section n x mm ²	Ø under armour ca.mm ± 10%	Outer-Ø ca.mm ± 10%	Copper weight kg/km	Cable weight approx. kg/km	AWG no.)*
12070G73050M62	5x16	18,8	23,8	814	1450	6
12070G73050M63	5x25	23,2	28,4	1272	2080	4
12070G73050M64	5x35	29,2	34,7	1730	2830	2
12070G71040M10	4x1	8,5	12,1	74	320	18
12070G71050M10	5x1	9,5	13,2	84	350	18
12070GG1070M10	7x1	10,5	14,3	108	400	18
12070GG1100M10	10x1	13,8	18,3	177	600	18
12070GG1120M10	12x1	14,5	18,8	240	650	18
12070GG1140M10	14x1	15,2	19,8	228	700	18
12070GG1160M10	16x1	16,3	20,7	246	750	18
12070GG1190M10	19x1	17,2	21,8	279	850	18
12070GG1240M10	24x1	20,7	25,8	352	1020	18
12070GG1270M10	27x1	21,2	26,3	-	1100	18
12070GG1300M10	30x1	22	26,8	408	1170	18
12070GG1370M10	37x1	24	29,3	-	1350	18
12070GG1070M15	7x1,5	11,5	15,8	145	550	16
12070GG1100M15	10x1,5	15	19,8	240	710	16
12070GG1120M15	12x1,5	15,7	20,3	-	770	16
12070GG1140M15	14x1,5	16,8	21,3	299	840	16
12070GG1160M15	16x1,5	17,7	22,2	328	890	16
12070GG1190M15	19x1,5	18,8	23,2	485	1000	16
12070GG1240M15	24x1,5	22,5	27,8	465	1230	16
12070GG1270M15	27x1,5	23	28,3	523	1330	16
12070GG1300M15	30x1,5	24	29,2	570	1430	16
12070GG1370M15	37x1,5	26	31,3	679	1640	16
12070GG1070M25	7x2,5	12,6	16,8	237	640	14
12070GG1100M25	10x2,5	16,7	21,5	-	850	14
12070GG1120M25	12x2,5	17,5	22,3	-	930	14
12070GG1140M25	14x2,5	18,4	23,2	-	1020	14
12070GG1160M25	16x2,5	19,5	24,3	-	1100	14
12070GG1190M25	19x2,5	20,8	25,8	549	1250	14
12070GG1240M25	24x2,5	25	30,3	-	1540	14
12070GG1270M25	27x2,5	25,5	30,9	-	1650	14
12070GG1300M25	30x2,5	26,5	31,7	-	1780	14
12070GG1370M25	37x2,5	30	34,3	-	2080	14

Other dimensions and colors available on request.

GAALSHIP® HF 250 OS

Pair twisted cables for telecommunication and instrumentation cables, overall screened



ELETTROTEK KABEL® GAALSHIP® HF 250 OS



Construction:

- Conductor:** stranded red copper conductor Cl. 2, acc. to IEC 60228, DIN VDE 0295
- Insulation:** XLPE Halogen free compound acc.to IEC 60092-351, thickness acc. to IEC 60092-376
- Stranding:** core laid-up together in pairs/triples/quads, laying up of pairs/triples/quads
- Overall screen:** aluminium/polyester tape with tinned copper stranded drain wire and syntetic tape
- Outer sheath:** Orange (RAL 2003), halogen free thermoplastic compound SHF1 acc. to IEC 60092-359, thickness acc. to IEC 60092-376

Technical data:

- Nominal voltage:** 150/250 V
- Temperature range:** -25°C up to +90°C
- Installation temp.:** -5°C
- Short circuit temperature:** +250°C
- Min. bending radius:** 6 x d

Resistance:



Flame and fire retardant acc. to:
IEC 60332-1-2,
IEC 60332-3-22



Halogen free acc. to:
IEC 60754-1/2



Smoke emission properties acc. to:
IEC 61034-1/2

Features:

- Sheathing materials acc. to: IEC 60092-359
Insulating materials acc. to: IEC 60092-351
Design guidelines acc. to: IEC 60092-350/376
Choice and installation of electric cables acc. to: IEC 60092-352 on request class 5
on request tinned copper conductor

We have possibility to provide the following Certifications on request:

- Det Norske Veritas (DNV)
- Lloyd's Register (LR)
- Germanischer Lloyd (GL)
- Bureau Veritas (BV)
- Registro Italiano Navale (RINA)
- American Bureau of Shipping (ABS)
- Other approvals on request



Available on stock CABLE GLANDS: see page 404 up to 416 of catalogue.

Part no.	No. of cores x cross section n x mm ²	Outer-Ø ca.mm ± 10%	Copper weight kg/km	Cable weight approx. kg/km	AWG no.®)
11040CGX012M05	1 x 2 x 0,5	7,5	14	80	20
11040CGX022M05	2 x 2 x 0,5	11	23	150	20
11040CGX032M05	3 x 2 x 0,5	11,4	32	160	20
11040CGX042M05	4 x 2 x 0,5	12,9	41	190	20
11040CGX052M05	5 x 2 x 0,5	14,7	50	220	20
11040CGX062M05	6 x 2 x 0,5	14,9	59	240	20
11040CGX072M05	7 x 2 x 0,5	15,5	68	260	20
11040CGX082M05	8 x 2 x 0,5	16,4	77	290	20
11040CGX102M05	10 x 2 x 0,5	17,8	95	340	20
11040CGX122M05	12 x 2 x 0,5	18,8	112	380	20
11040CGX142M05	14 x 2 x 0,5	20,3	130	450	20
11040CGX162M05	16 x 2 x 0,5	21,3	150	490	20
11040CGX192M05	19 x 2 x 0,5	22,9	175	560	20
11040CGX242M05	24 x 2 x 0,5	25,4	220	680	20
11040CGX272M05	27 x 2 x 0,5	26,7	275	760	20
11040CGX302M05	30 x 2 x 0,5	28,4	275	840	20
11040CGX322M05	32 x 2 x 0,5	29,9	293	880	20
11040CGX372M05	37 x 2 x 0,5	30,8	338	980	20
11040CGX012M07	1 x 2 x 0,75	7,9	18	90	19
11040CGX022M07	2 x 2 x 0,75	11,5	31	170	19
11040CGX032M07	3 x 2 x 0,75	12,1	45	180	19
11040CGX042M07	4 x 2 x 0,75	13,5	57	220	19
11040CGX052M07	5 x 2 x 0,75	15,8	70	240	19
11040CGX062M07	6 x 2 x 0,75	15,8	86	270	19
11040CGX072M07	7 x 2 x 0,75	16,8	96	300	19
11040CGX082M07	8 x 2 x 0,75	17,5	113	340	19

GAALSHIP® MARINE CABLES

GAALSHIP® HF 250 OS

Pair twisted cables for telecommunication and instrumentation cables, overall screened



ELETTROTEK KABEL® GAALSHIP® HF 250 OS



Part no.	No. of cores x cross section n x mm ²	Outer-Ø ca.mm ± 10%	Copper weight kg/km	Cable weight approx. kg/km	AWG no.®)
11040CGX102M07	10 x 2 x 0,75	18,8	135	390	19
11040CGX122M07	12 x 2 x 0,75	19,9	160	440	19
11040CGX142M07	14 x 2 x 0,75	21,4	186	510	19
11040CGX162M07	16 x 2 x 0,75	22,4	221	560	19
11040CGX192M07	19 x 2 x 0,75	24,5	251	640	19
11040CGX242M07	24 x 2 x 0,75	27,4	317	800	19
11040CGX272M07	27 x 2 x 0,75	28,3	369	900	19
11040CGX302M07	30 x 2 x 0,75	29,8	395	970	19
11040CGX322M07	32 x 2 x 0,75	31,4	437	1030	19
11040CGX372M07	37 x 2 x 0,75	32,8	504	1170	19
11040CGX012M10	1 x 2 x 1	8,2	23	100	18
11040CGX022M10	2 x 2 x 1	12,4	41	200	18
11040CGX032M10	3 x 2 x 1	12,9	59	220	18
11040CGX042M10	4 x 2 x 1	14,4	77	260	18
11040CGX052M10	5 x 2 x 1	16	95	300	18
11040CGX062M10	6 x 2 x 1	16,8	113	330	18
11040CGX072M10	7 x 2 x 1	17,4	131	370	18
11040CGX082M10	8 x 2 x 1	18,6	149	410	18
11040CGX102M10	10 x 2 x 1	20,9	185	490	18
11040CGX122M10	12 x 2 x 1	21,5	221	550	18
11040CGX142M10	14 x 2 x 1	22,8	257	630	18
11040CGX162M10	16 x 2 x 1	24,5	293	710	18
11040CGX192M10	19 x 2 x 1	26,4	347	810	18
11040CGX242M10	24 x 2 x 1	29,6	437	1010	18
11040CGX272M10	27 x 2 x 1	30,9	491	1110	18
11040CGX302M10	30 x 2 x 1	32,5	545	1220	18
11040CGX032M10	32 x 2 x 1	33,8	581	1300	18
11040CGX037M10	37 x 2 x 1	35,9	671	1470	18
11040CGX012M15	1 x 2 x 1,5	8,7	36	210	16
11040CGX022M15	2 x 2 x 1,5	13,5	64	250	16
11040CGX032M15	3 x 2 x 1,5	14,4	86	280	16
11040CGX042M15	4 x 2 x 1,5	15,8	120	330	16
11040CGX052M15	5 x 2 x 1,5	18,7	113	390	16
11040CGX062M15	6 x 2 x 1,5	19,0	167	430	16
11040CGX072M15	7 x 2 x 1,5	19,4	204	470	16
11040CGX082M15	8 x 2 x 1,5	20,3	221	530	16
11040CGX102M15	10 x 2 x 1,5	22,8	288	650	16
11040CGX122M15	12 x 2 x 1,5	23,9	329	730	16
11040CGX142M15	14 x 2 x 1,5	25,4	400	840	16
11040CGX162M15	16 x 2 x 1,5	26,7	437	950	16
11040CGX192M15	19 x 2 x 1,5	29,4	541	1100	16
11040CGX242M15	24 x 2 x 1,5	32,4	683	1350	16
11040CGX272M15	27 x 2 x 1,5	34,4	734	1500	16
11040CGX302M15	30 x 2 x 1,5	35,8	852	1660	16
11040CGX322M15	32 x 2 x 1,5	37,9	869	1760	16
11040CGX372M15	37 x 2 x 1,5	39,8	1004	2000	16
11040CGX013M05	1 x 3 x 0,5	7,8	18	90	20
11040CGX033M05	3 x 3 x 0,5	13,3	45	210	20
11040CGX043M05	4 x 3 x 0,5	13,6	59	230	20
11040CGX073M05	7 x 3 x 0,5	17,4	99	340	20
11040CGX123M05	12 x 3 x 0,5	21,8	162	520	20
11040CGX013M07	1 x 3 x 0,75	8,2	24	100	19
11040CGX033M07	3 x 3 x 0,75	13,6	65,5	230	19
11040CGX043M07	4 x 3 x 0,75	14,5	86	270	19
11040CGX073M07	7 x 3 x 0,75	18,4	146,5	390	19
11040CGX123M07	12 x 3 x 0,75	22,8	248	610	19
11040CGX013M10	1 x 3 x 1	8,6	32	110	18
11040CGX033M10	3 x 3 x 1	14,6	86	280	18
11040CGX043M10	4 x 3 x 1	15,6	113	320	18
11040CGX073M10	7 x 3 x 1	19,8	194	490	18
11040CGX123M10	12 x 3 x 1	24,8	329	760	18
11040CGX013M15	1 x 3 x 1,5	9,3	45	140	16
11040CGX033M15	3 x 3 x 1,5	16,4	126	350	16
11040CGX043M15	4 x 3 x 1,5	17,5	167	430	16
11040CGX073M15	7 x 3 x 1,5	21,8	288	650	16
11040CGX123M15	12 x 3 x 1,5	27,4	491	1020	16

Other dimensions and colors available on request.

GAALSHIP® HF 250 OS FR

Pair twisted cables for telecommunication and instrumentation cables, overall screened, fire resistant



ELETTROTEK KABEL® GAALSHIP® HF 250 OS FR



Construction:

Conductor:	stranded red copper conductor Cl. 2, acc. to IEC 60228, DIN VDE 0295
Insulation:	MICA glass tape + XLPE Halogen free compound acc.to IEC 60092-351, thickness acc. to IEC 60092-376
Stranding:	core laid-up together in pairs/triples/quads, laying up of pairs/triples/quads
Overall screen:	aluminium/polyester tape with tinned copper stranded drain wire and syntetic tape
Outer sheath:	Orange (RAL 2003), halogen free thermoplastic compound SHF1 acc. to IEC 60092-359, thickness acc. to IEC 60092-376

Technical data:

Nominal voltage:	150/250 V
Temperature range:	-25°C up to +90°C
<i>Installation temp.:</i>	-5°C
Short circuit temperature:	+250°C
Min. bending radius:	8 x d

Resistance:



Fire resistant acc. to:
IEC 60331



Flame and fire retardant acc. to:
IEC 60332-1-2,
IEC 60332-3-22



Halogen free acc. to:
IEC 60754-1/2



Smoke emission properties acc. to:
IEC 61034-1/2

Features:

Sheathing materials acc. to: IEC 60092-359
 Insulating materials acc. to: IEC 60092-351
 Design guidelines acc. to: IEC 60092-350/376
 Choice and installation of electric cables acc. to: IEC 60092-352
 on request class 5
 on request tinned copper conductor
We have possibility to provide the following Certifications on request:
 Det Norske Veritas (DNV)
 Lloyd's Register (LR)
 Germanisher Lloyd (GL)
 Bureau Veritas (BV)
 Registro Italiano Navale (RINA)
 American Bureau of Shipping (ABS)
 Other approvals on request



Available on stock CABLE GLANDS:
see page 404 up to 416 of catalogue.

GAALSHIP® HF 250 OS FR

Pair twisted cables for telecommunication and instrumentation cables, overall screened, fire resistant



ELETTROTEK KABEL® GAALSHIP® HF 250 OS FR



Part no.	No. of pairs/triples x cross section n x mm ²	Outer-Ø ca.mm ± 10%	Copper weight kg/km	Cable weight approx. kg/km	AWG no.®)
11050CGX012M07	1 x 2 x 0,75	9,8	18	130	19
11050CGX022M07	2 x 2 x 0,75	15,3	31	270	19
11050CGX032M07	3 x 2 x 0,75	16,4	45	280	19
11050CGX042M07	4 x 2 x 0,75	18,4	57	330	19
11050CGX052M07	5 x 2 x 0,75	21,4	70	390	19
11050CGX062M07	6 x 2 x 0,75	21,9	86	430	19
11050CGX072M07	7 x 2 x 0,75	22,3	96	470	19
11050CGX082M07	8 x 2 x 0,75	23,5	113	520	19
11050CGX102M07	10 x 2 x 0,75	26,4	135	620	19
11050CGX122M07	12 x 2 x 0,75	27,4	160	7 10	19
11050CGX142M07	14 x 2 x 0,75	29,3	186	810	19
11050CGX162M07	16 x 2 x 0,75	30,8	221	900	19
11050CGX192M07	19 x 2 x 0,75	33,8	251	1050	19
11050CGX242M07	24 x 2 x 0,75	37,4	317	1270	19
11050CGX272M07	27 x 2 x 0,75	39,8	369	1420	19
11050CGX302M07	30 x 2 x 0,75	41,8	395	1560	19
11050CGX322M07	32 x 2 x 0,75	43,8	437	1650	19
11050CGX372M07	37 x 2 x 0,75	45,7	504	1860	19
11050CGX012M10	1 x 2 x 1	10,1	23	140	18
11050CGX022M10	2 x 2 x 1	15,8	41	300	18
11050CGX032M10	3 x 2 x 1	16,8	59	330	18
11050CGX042M10	4 x 2 x 1	18,9	77	380	18
11050CGX052M10	5 x 2 x 1	21,6	95	440	18
11050CGX062M10	6 x 2 x 1	22,4	113	490	18
11050CGX072M10	7 x 2 x 1	22,4	131	530	18
11050CGX082M10	8 x 2 x 1	24,3	149	580	18
11050CGX102M10	10 x 2 x 1	27,5	185	710	18
11050CGX122M10	12 x 2 x 1	28,4	221	800	18
11050CGX142M10	14 x 2 x 1	30,3	257	910	18
11050CGX162M10	16 x 2 x 1	32,4	293	1020	18
11050CGX192M10	19 x 2 x 1	34,9	347	1180	18
11050CGX242M10	24 x 2 x 1	38,8	437	1460	18
11050CGX272M10	27 x 2 x 1	40,8	491	1620	18
11050CGX302M10	30 x 2 x 1	43,4	545	1800	18
11050CGX322M10	32 x 2 x 1	45,4	581	1890	18
11050CGX372M10	37 x 2 x 1	47,3	671	2130	18
11050CGX012M15	1 x 2 x 1,5	10,7	36	160	16
11050CGX022M15	2 x 2 x 1,5	17,5	64	350	16
11050CGX032M15	3 x 2 x 1,5	18,4	86	370	16
11050CGX042M15	4 x 2 x 1,5	20,3	120	450	16
11050CGX052M15	5 x 2 x 1,5	23,7	113	520	16
11050CGX062M15	6 x 2 x 1,5	24,4	167	580	16
11050CGX072M15	7 x 2 x 1,5	24,7	204	640	16
11050CGX082M15	8 x 2 x 1,5	25,8	221	720	16
11050CGX102M15	10 x 2 x 1,5	29,3	288	860	16
11050CGX122M15	12 x 2 x 1,5	30,4	329	970	16
11050CGX142M15	14 x 2 x 1,5	32,8	400	1130	16
11050CGX162M15	16 x 2 x 1,5	34,8	437	1260	16
11050CGX192M15	19 x 2 x 1,5	37,4	541	1470	16
11050CGX242M15	24 x 2 x 1,5	42,4	683	1830	16
11050CGX272M15	27 x 2 x 1,5	44,4	734	2020	16
11050CGX302M15	30 x 2 x 1,5	46,8	852	2230	16
11050CGX322M15	32 x 2 x 1,5	49,5	869	2350	16
11050CGX372M15	37 x 2 x 1,5	51,3	1004	2680	16

GAALSHIP® MARINE CABLES

GAALSHIP® HF 250 OS FR

Pair twisted cables for telecommunication and instrumentation cables, overall screened, fire resistant



ELETTROTEK KABEL® GAALSHIP® HF 250 OS FR



Part no.	No. of pairs/triples x cross section n x mm ²	Outer-Ø ca.mm ± 10%	Copper weight kg/km	Cable weight approx. kg/km	AWG no.*)
11050CGX013M07	1 x 3 x 0,75	10,4	24	140	19
11050CGX033M07	3 x 3 x 0,75	18,8	65,5	360	19
11050CGX043M07	4 x 3 x 0,75	19,5	86	410	19
11050CGX073M07	7 x 3 x 0,75	24,9	146,5	620	19
11050CGX123M07	12 x 3 x 0,75	31,8	248	960	19
11050CGX013M10	1 x 3 x 1	10,6	32	150	18
11050CGX033M10	3 x 3 x 1	19,3	86	400	18
11050CGX043M10	4 x 3 x 1	20,3	113	470	18
11050CGX073M10	7 x 3 x 1	25,7	194	700	18
11050CGX123M10	12 x 3 x 1	32,8	329	1090	18
11050CGX013M15	1 x 3 x 1,5	11,4	45	180	16
11050CGX033M15	3 x 3 x 1,5	20,7	126	480	16
11050CGX043M15	4 x 3 x 1,5	21,8	167	550	16
11050CGX073M15	7 x 3 x 1,5	28,4	288	860	16
11050CGX123M15	12 x 3 x 1,5	35,4	491	1350	16

Other dimensions and colors available on request.

GAALSHIP® HF 250 A

Pair twisted cables for telecommunication and instrumentation armoured



ELETTROTEK KABEL® GAALSHIP® HF 250 A



Construction:

Conductor:	stranded red copper conductor Cl. 2, acc. to IEC 60228, DIN VDE 0295
Insulation:	XLPE Halogen free compound acc. to IEC 60092-351, thickness acc. to IEC 60092-376
Stranding:	core laid-up together in pairs/triples/quads, laying up of pairs/triples/quads
Wrapping:	PETP foil
Armour:	red copper wires braid acc. to IEC 60092-350
Outer sheath:	Orange (RAL 2003), halogen free thermoplastic compound SHF1 acc. to IEC 60092-359, thickness acc. to IEC 60092-376

Technical data:

Nominal voltage:	150/250 V
Temperature range:	-25°C up to +90°C
<i>Installation temp.:</i>	-5°C
Short circuit temperature:	+250°C
Min. bending radius:	8 x d

Resistance:



Flame and fire retardant acc. to:
IEC 60332-1-2,
IEC 60332-3-22



Halogen free acc. to:
IEC 60754-1/2



Smoke emission properties acc. to:
IEC 61034-1/2

Features:

Sheathing materials acc. to: IEC 60092-359
Insulating materials acc. to: IEC 60092-351
Design guidelines acc. to: IEC 60092-350/376
Choice and installation of electric cables acc. to: IEC 60092-352
on request class 5 for sections up to 35 mm²
on request tinned copper conductor
on request tinned copper wire braid armour

We have possibility to provide the following Certifications on request:

Det Norske Veritas (DNV)
Lloyd's Register (LR)
Germanischer Lloyd (GL)
Bureau Veritas (BV)
Registro Italiano Navale (RINA)
American Bureau of Shipping (ABS)
Other approvals on request



Available on stock CABLE GLANDS:
see page 404 up to 416 of catalogue.

GAALSHIP® HF 250 A

Pair twisted cables for telecommunication and instrumentation armoured



ELETTROTEK KABEL® GAALSHIP® HF 250 A

Part no.	No. of pairs/triples x cross section n x mm ²	Outer-Ø ca.mm ± 10%	Copper weight kg/km	Cable weight approx. kg/km	AWG no.*)
11060CGX012M05	1 x 2 x 0,5	6,8	31	63	20
11060CGX022M05	2 x 2 x 0,5	9,6	54	106	20
11060CGX042M05	4 x 2 x 0,5	11,1	78	150	20
11060CGX062M05	6 x 2 x 0,5	13	102	206	20
11060CGX072M05	7 x 2 x 0,5	13	111	207	20
11060CGX082M05	8 x 2 x 0,5	84	125	234	20
11060CGX102M05	10 x 2 x 0,5	94	153	279	20
11060CGX122M05	12 x 2 x 0,5	16,6	171	315	20
11060CGX142M05	14 x 2 x 0,5	17,6	194	351	20
11060CGX192M05	19 x 2 x 0,5	20,1	249	449	20
11060CGX242M05	24 x 2 x 0,5	22,7	362	606	20
11060CGX272M05	27 x 2 x 0,5	23,8	390	652	20
11060CGX302M05	30 x 2 x 0,5	24,8	430	710	20
11060CGX372M05	37 x 2 x 0,5	27,2	495	829	20
11060CGX012M07	1 x 2 x 0,75	7,1	37	82	19
11060CGX022M07	2 x 2 x 0,75	10,4	69	128	19
11060CGX042M07	4 x 2 x 0,75	12,1	106	188	19
11060CGX062M07	6 x 2 x 0,75	14,4	148	274	19
11060CGX072M07	7 x 2 x 0,75	14,4	162	277	19
11060CGX082M07	8 x 2 x 0,75	15,2	178	301	19
11060CGX102M07	10 x 2 x 0,75	17,3	217	372	19
11060CGX142M07	14 x 2 x 0,75	19,4	286	480	19
11060CGX192M07	19 x 2 x 0,75	22,5	428	675	19
11060CGX242M07	24 x 2 x 0,75	25	531	819	19
11060CGX272M07	27 x 2 x 0,75	26,2	577	879	19
11060CGX302M07	30 x 2 x 0,75	27,5	622	970	19
11060CGX372M07	37 x 2 x 0,75	30,2	748	1158	19
11060CGX012M10	1 x 2 x 1	7,5	45	80	18
11060CGX022M10	2 x 2 x 1	10,9	81	141	18
11060CGX042M10	4 x 2 x 1	12,6	125	208	18
11060CGX062M10	6 x 2 x 1	15,1	173	300	18
11060CGX072M10	7 x 2 x 1	15,1	192	307	18
11060CGX082M10	8 x 2 x 1	16	216	341	18
11060CGX102M10	10 x 2 x 1	18,2	263	418	18
11060CGX122M10	12 x 2 x 1	19	303	469	18
11060CGX142M10	14 x 2 x 1	20,4	347	538	18
11060CGX192M10	19 x 2 x 1	23,7	511	754	18
11060CGX242M10	24 x 2 x 1	26,3	622	914	18
11060CGX272M10	27 x 2 x 1	27,6	694	1008	18
11060CGX302M10	30 x 2 x 1	29	752	1102	18
11060CGX372M10	37 x 2 x 1	31,7	904	1304	18
11060CGX012M15	1 x 2 x 1,5	8,5	58	100	16
11060CGX022M15	2 x 2 x 1,5	12,8	107	187	16
11060CGX042M15	4 x 2 x 1,5	14,9	173	284	16
11060CGX062M15	6 x 2 x 1,5	17,9	242	413	16
11060CGX072M15	7 x 2 x 1,5	18,1	269	426	16
11060CGX082M15	8 x 2 x 1,5	19,2	304	480	16
11060CGX102M15	10 x 2 x 1,5	20,6	371	577	16
11060CGX122M15	12 x 2 x 1,5	23,2	494	731	16
11060CGX142M15	14 x 2 x 1,5	24,7	560	824	16
11060CGX192M15	19 x 2 x 1,5	28,5	735	1090	16
11060CGX272M15	27 x 2 x 1,5	33,2	983	1434	16
11060CGX302M15	30 x 2 x 1,5	34,9	1070	1571	16
11060CGX372M15	37 x 2 x 1,5	38,3	1303	1885	16
11060CGX012M25	1 x 2 x 2,5	9,6	82	133	14
11060CGX022M25	2 x 2 x 2,5	14,5	154	250	14
11060CGX042M25	4 x 2 x 2,5	16,7	250	376	14
11060CGX062M25	6 x 2 x 2,5	20,3	360	559	14
11060CGX072M25	7 x 2 x 2,5	20,3	409	588	14
11060CGX082M25	8 x 2 x 2,5	22,2	508	718	14
11060CGX102M25	10 x 2 x 2,5	25,3	624	882	14
11060CGX122M25	12 x 2 x 2,5	26,4	724	1003	14
11060CGX142M25	14 x 2 x 2,5	28,1	838	1138	14

GAALSHIP® HF 250 A

Pair twisted cables for telecommunication and instrumentation armoured



ELETTROTEK KABEL® GAALSHIP® HF 250 A

Part no.	No. of pairs/triples x cross section n x mm ²	Outer-Ø ca.mm ± 10%	Copper weight kg/km	Cable weight approx. kg/km	AWG no.*)
11060CGX192M25	19 x 2 x 2,5	32,4	1092	1485	14
11060CGX242M25	24 x 2 x 2,5	36,2	1352	1840	14
11060CGX272M25	27 x 2 x 2,5	38	1511	2035	14
11060CGX302M25	30 x 2 x 2,5	40	1653	2222	14
11060CGX372M25	37 x 2 x 2,5	43,8	2020	2683	14
11060CGX013M05	1 x 3 x 0,5	7,1	36	70	20
11060CGX023M05	2 x 3 x 0,5	10,3	66	126	20
11060CGX043M05	4 x 3 x 0,5	12,3	99	183	20
11060CGX073M05	7 x 3 x 0,5	14,9	152	275	20
11060CGX103M05	10 x 3 x 0,5	18	203	367	20
11060CGX143M05	14 x 3 x 0,5	19,9	265	472	20
11060CGX193M05	19 x 3 x 0,5	22,9	402	653	20
11060CGX24M05	24 x 3 x 0,5	25,6	484	801	20
11060CGX013M07	1 x 3 x 0,75	7,5	48	85	19
11060CGX023M07	2 x 3 x 0,75	11,1	87	156	19
11060CGX043M07	4 x 3 x 0,75	12,9	139	229	19
11060CGX073M07	7 x 3 x 0,75	16	221	352	19
11060CGX103M07	10 x 3 x 0,75	19,5	300	483	19
11060CGX143M07	14 x 3 x 0,75	21,8	450	670	19
11060CGX193M07	19 x 3 x 0,75	24,9	591	869	19
11060CGX243M07	24 x 3 x 0,75	27,8	720	1070	19
11060CGX013M10	1 x 3 x 1	7,8	57	96	18
11060CGX023M10	2 x 3 x 1	11,8	103	177	18
11060CGX043M10	4 x 3 x 1	14	168	272	18
11060CGX073M10	7 x 3 x 1	17,1	233	373	18
11060CGX123M10	12 x 3 x 1	21,3	410	621	18
11060CGX143M10	14 x 3 x 1	23,5	549	797	18
11060CGX193M10	19 x 3 x 1	26,9	708	1023	18
11060CGX243M10	24 x 3 x 1	29,8	882	1262	18
11060CGX013M15	1 x 3 x 1,5	9,1	76	127	16
11060CGX023M15	2 x 3 x 1,5	13,9	141	239	16
11060CGX043M15	4 x 3 x 1,5	16,3	237	369	16
11060CGX073M15	7 x 3 x 1,5	20,5	382	582	16
11060CGX103M15	10 x 3 x 1,5	25,5	589	872	16
11060CGX143M15	14 x 3 x 1,5	28	778	1121	16
11060CGX193M15	19 x 3 x 1,5	32,1	1027	1459	16
11060CGX243M15	24 x 3 x 1,5	35,8	1254	1791	16
11060CGX013M25	1 x 3 x 2,5	10,1	108	165	14
11060CGX023M25	2 x 3 x 2,5	15,6	206	315	14
11060CGX043M25	4 x 3 x 2,5	18,5	358	510	14
11060CGX073M25	7 x 3 x 2,5	23,6	644	868	14
11060CGX103M25	10 x 3 x 2,5	29	899	1225	14
11060CGX143M25	14 x 3 x 2,5	32,1	1188	1591	14
11060CGX193M25	19 x 3 x 2,5	36,8	1577	2083	14
11060CGX243M25	24 x 3 x 2,5	41,1	1958	2586	14
11060CGX014M05	1 x 4 x 0,5	7,8	43	86	20
11060CGX014M07	1 x 4 x 0,75	8	62	104	19
11060CGX014M10	1 x 4 x 1	8,6	66	114	18
11060CGX014M15	1 x 4 x 1,5	10,1	92	156	16
11060CGX014M25	1 x 4 x 2,5	11,3	135	210	14

Other dimensions and colors available on request.

GAALSHIP® HF 250 A FR

Pair twisted cables for telecommunication and instrumentation, armoured, fire resistant



ELETTROTEK KABEL® GAALSHIP® HF 250 A FR



Construction:

Conductor:	stranded red copper conductor Cl. 2, acc. to IEC 60228, DIN VDE 0295
Insulation:	MICA glass tape + XLPE Halogen free compound acc. to IEC 60092-351, thickness acc. to IEC 60092-376
Stranding:	core laid-up together in pairs/triples/quads, laying up of pairs/triples/quads
Wrapping:	PETP tape
Armour:	red copper wires braid acc. to IEC 60092-350
Outer sheath:	Orange (RAL 2003), halogen free thermoplastic compound SHF1 acc. to IEC 60092-359, thickness acc. to IEC 60092-376

Technical data:

Nominal voltage:	150/250 V
Temperature range:	-25°C up to +90°C
<i>Installation temp.:</i>	-5°C
Short circuit temperature:	+250°C
Min. bending radius:	8 x d

Resistance:



Fire resistant acc. to:
IEC 60331



Flame and fire retardant acc. to:
IEC 60332-1-2,
IEC 60332-3-22



Halogen free acc. to:
IEC 60754-1/2



Smoke emission properties acc. to:
IEC 61034-1/2

Features:

Sheathing materials acc. to: IEC 60092-359
 Insulating materials acc. to: IEC 60092-351
 Design guidelines acc. to: IEC 60092-350/376
 Choice and installation of electric cables acc. to: IEC 60092-352
 on request class 5 for sections up to 35 mm²
 on request tinned copper conductor
 on request tinned copper wire braid armour

We have possibility to provide the following Certifications on request:

Det Norske Veritas (DNV)
 Lloyd's Register (LR)
 Germanischer Lloyd (GL)
 Bureau Veritas (BV)
 Registro Italiano Navale (RINA)
 American Bureau of Shipping (ABS)
 Other approvals on request



Available on stock CABLE GLANDS:
see page 404 up to 416 of catalogue.

GAALSHIP® HF 250 A FR

Pair twisted cables for telecommunication and instrumentation, armoured, fire resistant



ELETTROTEK KABEL® GAALSHIP® HF 250 A FR



Part no.	No. of pairs/triples/quads x cross section n x mm ²	Outer-Ø ca.mm ± 10%	Copper weight kg/km	Cable weight approx. kg/km	AWG no.*)
11070CGX012M05	1 x 2 x 0,5	7,2	38	89	20
11070CGX022M05	2 x 2 x 0,5	11,5	61	143	20
11070CGX042M05	4 x 2 x 0,5	13,8	122	240	20
11070CGX062M05	6 x 2 x 0,5	16,4	157	339	20
11070CGX072M05	7 x 2 x 0,5	16,4	166	339	20
11070CGX082M05	8 x 2 x 0,5	17,6	184	382	20
11070CGX102M05	10 x 2 x 0,5	20	211	456	20
11070CGX122M05	12 x 2 x 0,5	20,8	242	515	20
11070CGX142M05	14 x 2 x 0,5	22,3	261	576	20
11070CGX192M05	19 x 2 x 0,5	25,5	334	740	20
11070CGX242M05	24 x 2 x 0,5	28,2	396	891	20
11070CGX272M05	27 x 2 x 0,5	29,6	429	965	20
11070CGX302M05	30 x 2 x 0,5	31,2	467	1070	20
11070CGX372M05	37 x 2 x 0,5	34,2	549	1268	20
11070CGX012M07	1 x 2 x 0,75	8,2	44	91	19
11070CGX022M07	2 x 2 x 0,75	12,2	77	165	19
11070CGX042M07	4 x 2 x 0,75	14,3	114	248	19
11070CGX062M07	6 x 2 x 0,75	17,1	160	356	19
11070CGX072M07	7 x 2 x 0,75	17,1	176	366	19
11070CGX082M07	8 x 2 x 0,75	18,1	195	404	19
11070CGX102M07	10 x 2 x 0,75	21	287	549	19
11070CGX122M07	12 x 2 x 0,75	22,2	329	631	19
11070CGX142M07	14 x 2 x 0,75	23,6	373	710	19
11070CGX192M07	19 x 2 x 0,75	26,9	465	898	19
11070CGX242M07	24 x 2 x 0,75	29,8	558	1087	19
11070CGX272M07	27 x 2 x 0,75	31,5	628	1214	19
11070CGX302M07	30 x 2 x 0,75	33,2	671	1332	19
11070CGX372M07	37 x 2 x 0,75	36,2	802	1574	19
11070CGX012M10	1 x 2 x 1	8,9	51	106	18
11070CGX022M10	2 x 2 x 1	13,4	88	184	18
11070CGX082M10	8 x 2 x 1	20	274	516	18
11070CGX102M10	10 x 2 x 1	22,7	338	637	18
11070CGX122M10	12 x 2 x 1	23,7	378	711	18
11070CGX142M10	14 x 2 x 1	25,2	431	802	18
11070CGX192M10	19 x 2 x 1	29,2	544	1036	18
11070CGX242M10	24 x 2 x 1	32,2	657	1259	18
11070CGX272M10	27 x 2 x 1	34,1	735	1398	18
11070CGX302M10	30 x 2 x 1	36	879	1613	18
11070CGX372M10	37 x 2 x 1	39,6	1039	1917	18
11070CGX012M15	1 x 2 x 1,5	9,7	64	127	16
11070CGX022M15	2 x 2 x 1,5	15,1	153	274	16
11070CGX042M15	4 x 2 x 1,5	17,6	227	405	16
11070CGX062M15	6 x 2 x 1,5	21	307	575	16
11070CGX072M15	7 x 2 x 1,5	21	336	600	16
11070CGX082M15	8 x 2 x 1,5	22,5	377	677	16
11070CGX102M15	10 x 2 x 1,5	25,7	451	821	16
11070CGX122M15	12 x 2 x 1,5	26,8	509	922	16
11070CGX142M15	14 x 2 x 1,5	28,8	581	1058	16
11070CGX192M15	19 x 2 x 1,5	32,9	753	1370	16
11070CGX242M15	24 x 2 x 1,5	37,1	1001	1769	16
11070CGX272M15	27 x 2 x 1,5	39,2	1117	1961	16
11070CGX302M15	30 x 2 x 1,5	41	1206	2142	16
11070CGX372M15	37 x 2 x 1,5	45,3	1443	2580	16
11070CGX012M25	1 x 2 x 2,5	10,7	84	157	14
11070CGX022M25	2 x 2 x 2,5	16,9	199	344	14
11070CGX082M25	8 x 2 x 2,5	25,4	539	897	14
11070CGX102M25	10 x 2 x 2,5	29	647	1091	14
11070CGX122M25	12 x 2 x 2,5	30,5	759	1267	14
11070CGX142M25	14 x 2 x 2,5	32,6	855	1423	14
11070CGX192M25	19 x 2 x 2,5	37,9	1207	1957	14
11070CGX242M25	24 x 2 x 2,5	42,2	1483	2415	14
11070CGX272M25	27 x 2 x 2,5	44,6	1669	2685	14
11070CGX302M25	30 x 2 x 2,5	46,7	1821	2955	14
11070CGX372M25	37 x 2 x 2,5	51,7	2188	3587	14

GAALSHIP® HF 250 A FR

Pair twisted cables for telecommunication and instrumentation, armoured, fire resistant



ELETTROTEK KABEL® GAALSHIP® HF 250 A FR



Part no.	No. of pairs/triples/quads x cross section n x mm ²	Outer-Ø ca.mm ± 10%	Copper weight kg/km	Cable weight approx. kg/km	AWG no.*)
11070CGX013M05	1 x 3 x 0,5	8,2	42	93	20
11070CGX023M05	2 x 3 x 0,5	12,5	76	176	20
11070CGX043M05	4 x 3 x 0,5	15,2	148	302	20
11070CGX073M05	7 x 3 x 0,5	18,8	215	449	20
11070CGX103M05	10 x 3 x 0,5	22,8	283	613	20
11070CGX143M05	14 x 3 x 0,5	25,3	351	778	20
11070CGX193M05	19 x 3 x 0,5	28,8	435	986	20
11070CGX243M05	24 x 3 x 0,5	32	521	1196	20
11070CGX013M07	1 x 3 x 0,75	8,2	54	107	19
11070CGX023M07	2 x 3 x 0,75	13,5	98	203	19
11070CGX043M07	4 x 3 x 0,75	16	185	349	19
11070CGX073M07	7 x 3 x 0,75	20,1	279	539	19
11070CGX103M07	10 x 3 x 0,75	24,2	375	729	19
11070CGX143M07	14 x 3 x 0,75	26,8	480	936	19
11070CGX193M07	19 x 3 x 0,75	30,8	624	1228	19
11070CGX243M07	24 x 3 x 0,75	34,2	757	1494	19
11070CGX013M10	1 x 3 x 1	9,3	60	124	18
11070CGX023M10	2 x 3 x 1	13,4	144	184	18
11070CGX043M10	4 x 3 x 1	17,2	218	406	18
11070CGX103M10	10 x 3 x 1	26	449	852	18
11070CGX143M10	14 x 3 x 1	28,8	581	1099	18
11070CGX193M10	19 x 3 x 1	33,2	758	1443	18
11070CGX243M10	24 x 3 x 1	37,2	1000	1840	18
11070CGX023M15	2 x 3 x 1,5	16,3	190	337	16
11070CGX043M15	4 x 3 x 1,5	19,6	294	531	16
11070CGX073M15	7 x 3 x 1,5	24,4	451	812	16
11070CGX103M15	10 x 3 x 1,5	29,8	628	1135	16
11070CGX143M15	14 x 3 x 1,5	33,2	817	1487	16
11070CGX193M15	19 x 3 x 1,5	38,6	1142	2027	16
11070CGX243M15	24 x 3 x 1,5	42,8	1389	2479	16
11070CGX013M25	1 x 3 x 2,5	11,5	111	202	14
11070CGX023M25	2 x 3 x 2,5	18,2	254	430	14
11070CGX043M25	4 x 3 x 2,5	21,7	418	688	14
11070CGX073M25	7 x 3 x 2,5	27,5	673	1112	14
11070CGX103M25	10 x 3 x 2,5	33,5	923	1535	14
11070CGX143M25	14 x 3 x 2,5	37,6	1304	2095	14
11070CGX193M25	19 x 3 x 2,5	43,2	1706	2746	14
11070CGX243M25	24 x 3 x 2,5	48,1	2105	3398	14
11070CGX014M05	1 x 4 x 0,5	9,3	50	119	20
11070CGX014M07	1 x 4 x 0,75	9,5	68	137	19
11070CGX014M10	1 x 4 x 1	10,2	73	152	18
11070CGX014M15	1 x 4 x 1,5	11,3	98	192	16
11070CGX014M25	1 x 4 x 2,5	12,4	110	250	14

Other dimensions and colors available on request.

GAALSHIP® HF 250 OSA

Pair twisted cables for telecommunication and instrumentation, overall screened, armoured



ELETTROTEK KABEL® GAALSHIP® HF 250 OSA



Construction:

Conductor:	stranded red copper conductor Cl. 2, acc. to IEC 60228, DIN VDE 0295
Insulation:	XLPE Halogen free compound acc.to IEC 60092-351, thickness acc. to IEC 60092-376
Stranding:	core laid-up together in pairs/triples/quads, laying up of pairs/triples/quads
Overall screen:	aluminium/polyester tape with tinned copper stranded drain wire and syntetic tape
Wrapping:	synthetic tape
Armour:	red copper wires braid acc. to IEC 60092-350
Outer sheath:	Orange (RAL 2003), halogen free thermoplastic compound SHF1 acc. to IEC 60092-359, thickness acc. to IEC 60092-376

Technical data:

Nominal voltage:	150/250 V
Temperature range:	-25°C up to +90°C
Installation temp.:	-5°C
Short circuit temperature:	+250°C
Min. bending radius:	8 x d

Resistance:



Flame and fire retardant acc. to:
IEC 60332-1-2,
IEC 60332-3-22



Halogen free acc. to:
IEC 60754-1/2



Smoke emission properties acc. to:
IEC 61034-1/2

Features:

Sheathing materials acc. to: IEC 60092-359
Insulating materials acc. to: IEC 60092-351
Design guidelines acc. to: IEC 60092-350/376
Choice and installation of electric cables acc. to: IEC 60092-352
on request class 5 for sections up to 35 mm²
on request tinned copper conductor
on request tinned copper wire braid armour

We have possibility to provide the following Certifications on request:

Det Norske Veritas (DNV)
Lloyd's Register (LR)
Germanischer Lloyd (GL)
Bureau Veritas (BV)
Registro Italiano Navale (RINA)
American Bureau of Shipping (ABS)
Other approvals on request



Available on stock CABLE GLANDS: see page 404 up to 416 of catalogue.

GAALSHIP® HF 250 OSA

Pair twisted cables for telecommunication and instrumentation, overall screened, armoured



ELETTROTEK KABEL® GAALSHIP® HF 250 OSA



Part no.	No. of pairs/triples x cross section n x mm ²	Outer-Ø ca.mm ± 10%	Cable weight approx. kg/km	AWG no.)*
11080CGX012M05	1 x 2 x 0,5	8,7	110	20
11080CGX022M05	2 x 2 x 0,5	12,1	180	20
11080CGX032M05	3 x 2 x 0,5	12,5	210	20
11080CGX042M05	4 x 2 x 0,5	13,8	240	20
11080CGX052M05	5 x 2 x 0,5	15,8	280	20
11080CGX062M05	6 x 2 x 0,5	16,4	310	20
11080CGX072M05	7 x 2 x 0,5	16,7	320	20
11080CGX082M05	8 x 2 x 0,5	17,3	380	20
11080CGX102M05	10 x 2 x 0,5	19,4	470	20
11080CGX122M05	12 x 2 x 0,5	20,3	510	20
11080CGX142M05	14 x 2 x 0,5	21,8	570	20
11080CGX162M05	16 x 2 x 0,5	22,8	630	20
11080CGX192M05	19 x 2 x 0,5	24,4	710	20
11080CGX242M05	24 x 2 x 0,5	26,8	830	20
11080CGX272M05	27 x 2 x 0,5	28,4	910	20
11080CGX302M05	30 x 2 x 0,5	29,8	980	20
11080CGX322M05	32 x 2 x 0,5	31,4	1040	20
11080CGX372M05	37 x 2 x 0,5	32,4	1160	20
11080CGX012M07	1 x 2 x 0,75	8,9	120	19
11080CGX022M07	2 x 2 x 0,75	12,5	190	19
11080CGX032M07	3 x 2 x 0,75	13,3	210	19
11080CGX042M07	4 x 2 x 0,75	14,5	250	19
11080CGX052M07	5 x 2 x 0,75	16,8	310	19
11080CGX062M07	6 x 2 x 0,75	17,4	340	19
11080CGX072M07	7 x 2 x 0,75	17,8	350	19
11080CGX082M07	8 x 2 x 0,75	18,4	420	19
11080CGX102M07	10 x 2 x 0,75	20,4	520	19
11080CGX122M07	12 x 2 x 0,75	21,4	570	19
11080CGX142M07	14 x 2 x 0,75	22,8	630	19
11080CGX162M07	16 x 2 x 0,75	23,8	710	19
11080CGX192M07	19 x 2 x 0,75	25,9	790	19
11080CGX242M07	24 x 2 x 0,75	28,8	940	19
11080CGX272M07	27 x 2 x 0,75	29,8	1030	19
11080CGX302M07	30 x 2 x 0,75	31,4	1130	19
11080CGX322M10	32 x 2 x 0,75	32,9	1190	19
11080CGX372M10	37 x 2 x 0,75	34,4	1320	19
11080CGX012M10	1 x 2 x 1	9,4	150	18
11080CGX022M10	2 x 2 x 1	13,4	220	18
11080CGX032M10	3 x 2 x 1	14,1	250	18
11080CGX042M10	4 x 2 x 1	15,9	310	18
11080CGX052M10	5 x 2 x 1	18,4	370	18
11080CGX062M10	6 x 2 x 1	18,7	420	18
11080CGX072M10	7 x 2 x 1	18,9	470	18
11080CGX082M10	8 x 2 x 1	19,8	510	18
11080CGX102M10	10 x 2 x 1	21,7	620	18
11080CGX122M10	12 x 2 x 1	22,9	680	18
11080CGX142M10	14 x 2 x 1	24,4	770	18
11080CGX162M10	16 x 2 x 1	25,8	850	18
11080CGX192M10	19 x 2 x 1	27,8	950	18
11080CGX242M10	24 x 2 x 1	30,8	1150	18
11080CGX272M10	27 x 2 x 1	32,4	1260	18
11080CGX302M10	30 x 2 x 1	33,9	1380	18
11080CGX322M10	32 x 2 x 1	35,7	1450	18
11080CGX372M10	37 x 2 x 1	37,5	1620	18
11080CGX012M15	1 x 2 x 1,5	9,9	160	16
11080CGX022M15	2 x 2 x 1,5	14,5	260	16
11080CGX032M15	3 x 2 x 1,5	15,4	315	16
11080CGX032M15	4 x 2 x 1,5	17,4	420	16
11080CGX052M15	5 x 2 x 1,5	20,3	460	16
11080CGX062M15	6 x 2 x 1,5	20,5	530	16
11080CGX072M15	7 x 2 x 1,5	20,7	590	16
11080CGX082M15	8 x 2 x 1,5	21,8	640	16
11080CGX102M15	10 x 2 x 1,5	24,8	760	16
11080CGX122M15	12 x 2 x 1,5	25,8	870	16

GAALSHIP® MARINE CABLES

GAALSHIP® HF 250 OSA

Pair twisted cables for telecommunication and instrumentation, overall screened, armoured



ELETTROTEK KABEL® GAALSHIP® HF 250 OSA



Part no.	No. of pairs/triples x cross section n x mm ²	Outer-Ø ca.mm ± 10%	Cable weight approx. kg/km	AWG no.)*
11080CGX142M15	14 x 2 x 1,5	26,8	1010	16
11080CGX162M15	16 x 2 x 1,5	28,5	1100	16
11080CGX192M15	19 x 2 x 1,5	30,3	1250	16
11080CGX242M15	24 x 2 x 1,5	33,9	1500	16
11080CGX272M15	27 x 2 x 1,5	35,8	1650	16
11080CGX302M15	30 x 2 x 1,5	37,4	1810	16
11080CGX322M15	32 x 2 x 1,5	39,4	1910	16
11080CGX372M15	37 x 2 x 1,5	41,4	2160	16
11080CGX013M05	1 x 3 x 0,5	9,2	130	20
11080CGX033M05	3 x 3 x 0,5	13,9	250	20
11080CGX043M05	4 x 3 x 0,5	14,8	280	20
11080CGX073M05	7 x 3 x 0,5	18,4	400	20
11080CGX123M05	12 x 3 x 0,5	23,3	670	20
11080CGX013M07	1 x 3 x 0,75	9,3	130	19
11080CGX033M07	3 x 3 x 0,75	14,7	270	19
11080CGX043M07	4 x 3 x 0,75	15,1	310	19
11080CGX073M07	7 x 3 x 0,75	19,9	520	19
11080CGX123M07	12 x 3 x 0,75	24,3	760	19
11080CGX013M10	1 x 3 x 1	9,8	160	18
11080CGX023M10	3 x 3 x 1	15,9	320	18
11080CGX043M10	4 x 3 x 1	16,9	370	18
11080CGX073M10	7 x 3 x 1	21,4	600	18
11080CGX123M10	12 x 3 x 1	26,3	900	18
11080CGX013M15	1 x 3 x 1,5	10,5	190	16
11080CGX033M15	3 x 3 x 1,5	17,9	450	16
11080CGX043M15	4 x 3 x 1,5	18,4	520	16
11080CGX073M15	7 x 3 x 1,5	23,4	770	16
11080CGX123M15	12 x 3 x 1,5	28,8	1170	16

Other dimensions and colors available on request.

GAALSHIP® HF 250 OSA FR

Pair twisted cables for telecommunication and instrumentation, overall screened, armoured and fire resistant



ELETTROTEK KABEL® GAALSHIP® HF 250 OSA FR



Construction:

Conductor:	stranded red copper conductor Cl. 2, acc. to IEC 60228, DIN VDE 0295
Insulation:	MICA glass tape + XLPE Halogen free compound acc. to IEC 60092-351, thickness acc. to IEC 60092-376
Stranding:	core laid-up together in pairs/triples/quads, laying up of pairs/triples/quads
Overall screen:	aluminium/polyester tape with tinned copper stranded drain wire and syntetic tape
Wrapping:	synthetic tape
Armour:	red copper wires braid acc. to IEC 60092-350
Outer sheath:	Orange (RAL 2003), halogen free thermoplastic compound SHF1 acc. to IEC 60092-359, thickness acc. to IEC 60092-376

Technical data:

Nominal voltage:	150/250 V
Temperature range:	-25°C up to +90°C
Installation temp.:	-5°C
Short circuit temperature:	+250°C
Min. bending radius:	8 x d

Resistance:



Fire resistant acc. to:
IEC 60331



flame and fire retardant acc. to:
IEC 60332-3-22 + IEC 60332-1-2



Halogen free acc. to:
IEC 60754 -1-2



Smoke emission properties acc. to:
IEC 61034 -1-2

Features:

Sheathing materials acc. to: IEC 60092-359
 Insulating materials acc. to: IEC 60092-351
 Design guidelines acc. to: IEC 60092-350/376
 Choice and installation of electric cables acc. to: IEC 60092-352
 on request class 5
 on request tinned copper conductor

We have possibility to provide the following Certifications on request:

- Det Norske Veritas (DNV)
- Lloyd's Register (LR)
- Germanisher Lloyd (GL)
- Bureau Veritas (BV)
- Registro Italiano Navale (RINA)
- American Bureau of Shipping (ABS)
- Other approvals on request



Available on stock CABLE GLANDS:
see page 404 up to 416 of catalogue.

GAALSHIP® HF 250 OSA FR

Pair twisted cables for telecommunication and instrumentation, overall screened, armored and fire resistant



ELETTROTEK KABEL® GAALSHIP® HF 250 OSA FR



Part no.	No. of pairs/triples x cross section n x mm ²	Outer-Ø ca.mm ± 10%	Cable weight approx. kg/km	AWG no.)*
11090CGX012M07	1 x 2 x 0,75	10,3	130	19
11090CGX022M07	2 x 2 x 0,75	16,4	210	19
11090CGX032M07	3 x 2 x 0,75	16,8	240	19
11090CGX042M07	4 x 2 x 0,75	19,4	290	19
11090CGX052M07	5 x 2 x 0,75	22,3	350	19
11090CGX062M07	6 x 2 x 0,75	22,8	400	19
11090CGX072M07	7 x 2 x 0,75	23,4	410	19
11090CGX082M07	8 x 2 x 0,75	23,8	490	19
11090CGX102M07	10 x 2 x 0,75	26,7	610	19
11090CGX122M07	12 x 2 x 0,75	27,9	670	19
11090CGX142M07	14 x 2 x 0,75	29,8	760	19
11090CGX162M07	16 x 2 x 0,75	31,8	850	19
11090CGX192M07	19 x 2 x 0,75	34,4	950	19
11090CGX242M07	24 x 2 x 0,75	37,8	1150	19
11090CGX272M07	27 x 2 x 0,75	40,3	1250	19
11090CGX302M07	30 x 2 x 0,75	41,8	1370	19
11090CGX322M07	32 x 2 x 0,75	44,4	1450	19
11090CGX372M07	37 x 2 x 0,75	46,3	1610	19
11090CGX012M10	1 x 2 x 1	10,9	160	18
11090CGX022M10	2 x 2 x 1	16,9	240	18
11090CGX032M10	3 x 2 x 1	17,8	290	18
11090CGX042M10	4 x 2 x 1	20,4	360	18
11090CGX052M10	5 x 2 x 1	23,3	430	18
11090CGX062M10	6 x 2 x 1	23,8	500	18
11090CGX072M10	7 x 2 x 1	24,4	560	18
11090CGX082M10	8 x 2 x 1	25,8	620	18
11090CGX102M10	10 x 2 x 1	28,5	750	18
11090CGX122M10	12 x 2 x 1	29,4	830	18
11090CGX142M10	14 x 2 x 1	31,3	950	18
11090CGX162M10	16 x 2 x 1	33,4	1050	18
11090CGX192M10	19 x 2 x 1	35,8	1200	18
11090CGX242M10	24 x 2 x 1	40,4	1460	18
11090CGX272M10	27 x 2 x 1	42,3	1610	18
11090CGX302M10	30 x 2 x 1	44,3	1770	18
11090CGX322M10	32 x 2 x 1	46,8	1850	18
11090CGX372M10	37 x 2 x 1	48,8	2100	18
11090CGX012M15	1 x 2 x 1,5	11,6	180	16
11090CGX022M15	2 x 2 x 1,5	18,9	290	16
11090CGX032M15	3 x 2 x 1,5	19,8	360	16
11090CGX042M15	4 x 2 x 1,5	21,9	480	16
11090CGX052M15	5 x 2 x 1,5	25,3	530	16
11090CGX062M15	6 x 2 x 1,5	25,6	610	16
11090CGX072M15	7 x 2 x 1,5	26,4	690	16
11090CGX082M15	8 x 2 x 1,5	27,3	770	16
11090CGX102M15	10 x 2 x 1,5	30,8	910	16
11090CGX122M15	12 x 2 x 1,5	31,9	1050	16
11090CGX142M15	14 x 2 x 1,5	34,3	1170	16
11090CGX162M15	16 x 2 x 1,5	36,4	1320	16
11090CGX192M15	19 x 2 x 1,5	38,8	1510	16
11090CGX242M15	24 x 2 x 1,5	43,8	1850	16
11090CGX272M15	27 x 2 x 1,5	46,3	2030	16
11090CGX302M15	30 x 2 x 1,5	48,4	2230	16
11090CGX322M15	32 x 2 x 1,5	50,9	2360	16
11090CGX372M15	37 x 2 x 1,5	53,4	2670	16

GAALSHIP® MARINE CABLES

GAALSHIP® HF 250 OSA FR

Pair twisted cables for telecommunication and instrumentation, overall screened, armored and fire resistant



ELETTROTEK KABEL® GAALSHIP® HF 250 OSA FR



Part no.	No. of pairs/triples x cross section n x mm ²	Outer-Ø ca.mm ± 10%	Cable weight approx. kg/km	AWG no.)*
11090CGX013M07	1 x 3 x 0,75	10,9	140	19
11090CGX033M07	3 x 3 x 0,75	19,8	300	19
11090CGX043M07	4 x 3 x 0,75	20,3	350	19
11090CGX073M07	7 x 3 x 0,75	25,8	600	19
11090CGX123M07	12 x 3 x 0,75	32,4	910	19
11090CGX013M10	1 x 3 x 1	11,4	180	18
11090CGX033M10	3 x 3 x 1	20,8	380	18
11090CGX043M10	4 x 3 x 1	21,4	440	18
11090CGX073M10	7 x 3 x 1	27,4	740	18
11090CGX123M10	12 x 3 x 1	34,3	1140	18
11090CGX013M15	1 x 3 x 1,5	11,9	210	16
11090CGX033M15	3 x 3 x 1,5	22,4	520	16
11090CGX043M15	4 x 3 x 1,5	22,8	610	16
11090CGX073M15	7 x 3 x 1,5	29,4	930	16
11090CGX123M15	12 x 3 x 1,5	36,9	1420	16

Other dimensions and colors available on request.

GAALSHIP® HF 250 IS

individually screened, telecommunication and instrumentation cable



ELETTROTEK KABEL® GAALSHIP® HF 250 IS



Construction:

Conductor:	stranded red copper conductor Cl. 2, acc. to IEC 60228, DIN VDE 0295
Insulation:	XLPE Halogen free compound acc.to IEC 60092-351, thickness acc. to IEC 60092-376
Stranding:	core laid-up together in pairs/triples/quads, laying up of pairs/triples/quads
Individual screen:	aluminium/polyester tape with tinned copper stranded drain wire and syntetic tape
Outer sheath:	Orange (RAL 2003), halogen free thermoplastic compound SHF1 acc. to IEC 60092-359, thickness acc. to IEC 60092-376

Resistance:



Flame and fire retardant acc. to:
IEC 60332-1-2,
IEC 60332-3-22



Halogen free acc. to:
IEC 60754-1/2



Smoke emission properties acc. to:
IEC 61034-1/2

Technical data:

Nominal voltage:	150/250 V
Temperature range:	-25°C up to +90°C
Installation temp.:	-5°C
Short circuit temperature:	+250°C
Min. bending radius:	8 x d

Features:

Sheathing materials acc. to: IEC 60092-359
Insulating materials acc. to: IEC 60092-351
Design guidelines acc. to: IEC 60092-350/376
Choice and installation of electric cables acc. to: IEC 60092-352
on request class 5
on request tinned copper conductor

We have possibility to provide the following Certifications on request:

Det Norske Veritas (DNV)
Lloyd's Register (LR)
Germanischer Lloyd (GL)
Bureau Veritas (BV)
Registro Italiano Navale (RINA)
American Bureau of Shipping (ABS)
Other approvals on request



Available on stock CABLE GLANDS:
see page 404 up to 416 of catalogue.

GAALSHIP® HF 250 IS

individually screened, telecommunication and instrumentation cable



ELETTROTEK KABEL® GAALSHIP® HF 250 IS



Part no.	No. of pairs/triples x cross section n x mm ²	Outer-Ø ca.mm ± 10%	Copper weight kg/km	Cable weight approx. kg/km	AWG no.)*
11100CGX022M05	2x2x0,5	10,8	19,2	110	20
11100CGX042M05	4x2x0,5	13,2	38,4	155	20
11100CGX072M05	7x2x0,5	15,5	67,2	245	20
11100CGX102M05	10x2x0,5	19,2	96	340	20
11100CGX142M05	14x2x0,5	21,0	115,2	455	20
11100CGX192M05	19x2x0,5	23,6	182,4	590	20
11100CGX242M05	24x2x0,5	26,9	230,4	740	20
11100CGX302M05	30x2x0,5	28,4	288	880	20
11100CGX022M07	2x2x0,75	12,6	31	155	19
11100CGX042M07	4x2x0,75	15,3	56	220	19
11100CGX072M07	7x2x0,75	18,2	95	345	19
11100CGX102M07	10x2x0,75	23,1	134	490	19
11100CGX142M07	14x2x0,75	25,2	186	650	19
11100CGX192M07	19x2x0,75	28,2	250	840	19
11100CGX242M07	24x2x0,75	32,3	345,6	1040	19
11100CGX302M07	30x2x0,75	34,4	394	1260	19
11100CGX022M10	2x2x1	13,1	38,4	165	19
11100CGX042M10	4x2x1	16,2	76,8	250	19
11100CGX072M10	7x2x1	19,4	134,4	390	19
11100CGX102M10	10x2x1	24,3	192,0	540	19
11100CGX142M10	14x2x1	26,6	268,8	720	19
11100CGX192M10	19x2x1	30,1	364,8	960	18
11100CGX242M10	24x2x1	34,3	460,8	1200	18
11100CGX302M10	30x2x1	36,6	576	1460	18
11100CGX043M10	4x3x1	17,6	115,2	325	18
11100CGX073M10	7x3x1	21,5	201,6	520	18
11100CGX103M10	10x3x1	26,9	288	730	18
11100CGX143M10	14x3x1	29,5	403,2	980	18
11100CGX193M10	19x3x1	33,2	547,2	1300	18
11100CGX022M15	2x2x1,5	14,0	57,6	190	16
11100CGX042M15	4x2x1,5	17,4	115,2	300	16
11100CGX072M15	7x2x1,5	21,0	201,6	475	16
11100CGX102M15	10x2x1,5	26,6	288,0	680	16
11100CGX142M15	14x2x1,5	29,1	403,2	910	16
11100CGX192M15	19x2x1,5	32,6	547,2	1180	16
11100CGX242M15	24x2x1,5	37,5	691,2	1500	16
11100CGX302M15	30x2x1,5	39,9	864	1840	16
11100CGX043M15	4x3x1,5	19,3	172,8	415	16
11100CGX073M15	7x3x1,5	23,4	302,4	670	16
11100CGX103M15	10x3x1,5	29,4	432	940	16
11100CGX143M15	14x3x1,5	32,2	604,8	1260	16
11100CGX193M15	19x3x1,5	36,3	820,8	1660	16

Other dimensions and colors available on request.

GAALSHIP® HF 250 ISA

individually screened, armoured, telecommunication and instrumentation cable



ELETTROTEK KABEL® GAALSHIP® HF 250 ISA



Construction:

Conductor:	stranded red copper conductor Cl. 2, acc. to IEC 60228, DIN VDE 0295
Insulation:	XLPE Halogen free compound acc. to IEC 60092-351, thickness acc. to IEC 60092-376
Stranding:	core laid-up together in pairs/triples/quads, laying up of pairs/triples/quads
Individual screen:	aluminium/polyester tape with tinned copper stranded drain wire and syntetic tape
Armour:	red copper wires braid acc. to IEC 60092-350
Outer sheath:	Orange (RAL 2003), halogen free thermoplastic compound SHF1 acc. to IEC 60092-359, thickness acc. to IEC 60092-376

Technical data:

Nominal voltage:	150/250 V
Temperature range:	-25°C up to +90°C
<i>Installation temp.:</i>	-5°C
Short circuit temperature:	+250°C
Min. bending radius:	8 x d

Resistance:



Flame and fire retardant acc. to:
IEC 60332-1-2,
IEC 60332-3-22



Halogen free acc. to:
IEC 60754-1/2



Smoke emission properties acc. to:
IEC 61034-1/2

Features:

Sheathing materials acc. to: IEC 60092-359
Insulating materials acc. to: IEC 60092-351
Design guidelines acc. to: IEC 60092-350/376
Choice and installation of electric cables acc. to: IEC 60092-352
on request class 5 for sections up to 35 mm²
on request tinned copper conductor
on request tinned copper wire braid armour

We have possibility to provide the following Certifications on request:

Det Norske Veritas (DNV)
Lloyd's Register (LR)
Germanischer Lloyd (GL)
Bureau Veritas (BV)
Registro Italiano Navale (RINA)
American Bureau of Shipping (ABS)
Other approvals on request



Available on stock CABLE GLANDS:
see page 404 up to 416 of catalogue.

GAALSHIP® MARINE CABLES

GAALSHIP® HF 250 ISA

individually screened, armoured, telecommunication and instrumentation cable



ELETTROTEK KABEL® GAALSHIP® HF 250 ISA

Part no.	No. of pairs/triples x cross section n x mm ²	Outer-Ø ca.mm ± 10%	Cable weight approx. kg/km	AWG no.*)
11110CGX022M05	2x2x0,5	12,2	165	20
11110CGX042M05	4x2x0,5	14,4	220	20
11110CGX072M05	7x2x0,5	17,2	355	20
11110CGX102M05	10x2x0,5	21,1	475	20
11110CGX142M05	14x2x0,5	22,9	600	20
11110CGX192M05	19x2x0,5	25,4	760	20
11110CGX242M05	24x2x0,5	28,7	930	20
11110CGX302M05	30x2x0,5	30,5	1100	20
11110CGX022M07	2x2x0,75	13,6	170	19
11110CGX042M07	4x2x0,75	17,0	300	19
11110CGX072M07	7x2x0,75	20,1	420	19
11110CGX102M07	10x2x0,75	24,9	630	19
11110CGX142M07	14x2x0,75	27,1	760	19
11110CGX192M07	19x2x0,75	30,1	1000	19
11110CGX242M07	24x2x0,75	34,1	1190	19
11110CGX302M07	30x2x0,75	36,2	1460	19
11110CGX022M10	2x2x1	14,8	250	18
11110CGX042M10	4x2x1	18,0	360	18
11110CGX072M10	7x2x1	21,3	520	18
11110CGX102M10	10x2x1	26,2	710	18
11110CGX142M10	14x2x1	28,5	900	18
11110CGX192M10	19x2x1	31,9	1160	18
11110CGX242M10	24x2x1	36,2	1420	18
11110CGX302M10	30x2x1	39,0	1760	18
11110CGX043M10	4x3x1	19,5	435	18
11110CGX073M10	7x3x1	23,3	650	18
11110CGX103M10	10x3x1	28,8	900	18
11110CGX143M10	14x3x1	31,3	1160	18
11110CGX193M10	19x3x1	35,1	1500	18
11110CGX022M15	2x2x1,5	15,7	285	16
11110CGX042M15	4x2x1,5	19,3	420	16
11110CGX072M15	7x2x1,5	22,8	620	16
11110CGX102M15	10x2x1,5	28,4	860	16
11110CGX142M15	14x2x1,5	30,9	1100	16
11110CGX192M15	19x2x1,5	34,7	1420	16
11110CGX242M15	24x2x1,5	39,9	1840	16
11110CGX302M15	30x2x1,5	42,3	2180	16
11110CGX043M15	4x3x1,5	21,1	530	16
11110CGX073M15	7x3x1,5	25,1	800	16
11110CGX103M15	10x3x1,5	31,3	1120	16
11110CGX143M15	14x3x1,5	34,1	1440	16
11110CGX193M15	19x3x1,5	38,7	1960	16

Other dimensions and colors available on request.

GAALSHIP® HF 250 ISOS

individually and overall screened, telecommunication and instrumentation cable



ELETTROTEK KABEL® GAALSHIP® HF 250 ISOS



Construction:

Conductor:	stranded red copper conductor Cl. 2, acc. to IEC 60228, DIN VDE 0295
Insulation:	XLPE Halogen free compound acc.to IEC 60092-351, thickness acc. to IEC 60092-376
Stranding:	core laid-up together in pairs/triples/quads
Individual screen:	aluminium/polyester tape with tinned copper stranded drain wire and syntetic tape
Stranding:	laying up of pairs/triples/quads
Overall screen:	aluminium/polyester tape with tinned copper stranded drain wire and syntetic tape
Outer sheath:	Orange (RAL 2003), halogen free thermoplastic compound SHF1 acc. to IEC 60092-359, thickness acc. to IEC 60092-376

Resistance:



Flame and fire retardant acc. to:
IEC 60332-1-2,
IEC 60332-3-22



Halogen free acc. to:
IEC 60754-1/2



Smoke emission properties acc. to:
IEC 61034-1/2

Technical data:

Nominal voltage:	150/250 V
Temperature range:	-25°C up to +90°C
Installation temp.:	-5°C
Short circuit temperature:	+250°C
Min. bending radius:	8 x d

Features:

Sheathing materials acc. to: IEC 60092-359
Insulating materials acc. to: IEC 60092-351
Design guidelines acc. to: IEC 60092-350/376
Choice and installation of electric cables acc. to: IEC 60092-352
on request class 5
on request tinned copper conductor

We have possibility to provide the following Certifications on request:

Det Norske Veritas (DNV)
Lloyd's Register (LR)
Germanischer Lloyd (GL)
Bureau Veritas (BV)
Registro Italiano Navale (RINA)
American Bureau of Shipping (ABS)
Other approvals on request



**Available on stock CABLE GLANDS:
see page 404 up to 416 of catalogue.**

GAALSHIP® HF 250 ISOS

individually and overall screened, telecommunication and instrumentation cable



ELETTROTEK KABEL® GAALSHIP® HF 250 ISOS



Part no.	No. of pairs/triples x cross section n x mm ²	Outer-Ø ca.mm ± 10%	Copper weight kg/km	Cable weight approx. kg/km	AWG no.*)
11120CGX022M05	2 x 2 x 0,5	11,7	32	180	20
11120CGX032M05	3 x 2 x 0,5	12,3	45	200	20
11120CGX042M05	4 x 2 x 0,5	13,7	59	250	20
11120CGX052M05	5 x 2 x 0,5	15,8	72	280	20
11120CGX062M05	6 x 2 x 0,5	15,8	86	310	20
11120CGX072M05	7 x 2 x 0,5	16,4	99	330	20
11120CGX082M05	8 x 2 x 0,5	17,3	113	380	20
11120CGX102M05	10 x 2 x 0,5	19,4	140	460	20
11120CGX122M05	12 x 2 x 0,5	20,3	167	510	20
11120CGX142M05	14 x 2 x 0,5	21,5	194	590	20
11120CGX162M05	16 x 2 x 0,5	22,8	221	650	20
11120CGX192M05	19 x 2 x 0,5	24,4	261	760	20
11120CGX242M05	24 x 2 x 0,5	27,5	329	940	20
11120CGX272M05	27 x 2 x 0,5	28,8	369	1050	20
11120CGX302M05	30 x 2 x 0,5	30,4	410	1150	20
11120CGX322M05	32 x 2 x 0,5	31,8	437	1200	20
11120CGX372M05	37 x 2 x 0,5	33,3	504	1380	20
11120CGX022M07	2 x 2 x 0,75	12,2	41	200	19
11120CGX032M07	3 x 2 x 0,75	12,7	59	230	19
11120CGX042M07	4 x 2 x 0,75	14,0	77	260	19
11120CGX052M07	5 x 2 x 0,75	16,7	95	300	19
11120CGX062M07	6 x 2 x 0,75	16,9	113	340	19
11120CGX072M07	7 x 2 x 0,75	17,4	131	370	19
11120CGX082M07	8 x 2 x 0,75	18,3	149	420	19
11120CGX102M07	10 x 2 x 0,75	20,3	186	500	19
11120CGX122M07	12 x 2 x 0,75	21,4	166,5	580	19
11120CGX142M07	14 x 2 x 0,75	22,3	258	650	19
11120CGX162M07	16 x 2 x 0,75	23,9	221	730	19
11120CGX192M07	19 x 2 x 0,75	25,8	348	850	19
11120CGX242M07	24 x 2 x 0,75	28,9	411	1050	19
11120CGX272M07	27 x 2 x 0,75	30,5	491	1160	19
11120CGX302M07	30 x 2 x 0,75	31,9	549	1290	19
11120CGX322M07	32 x 2 x 0,75	33,7	594	1360	19
11120CGX372M07	37 x 2 x 0,75	34,9	671	1550	19
11120CGX022M10	2 x 2 x 1	12,8	50	240	18
11120CGX032M10	3 x 2 x 1	13,7	87	260	18
11120CGX042M10	4 x 2 x 1	15,3	95	320	18
11120CGX052M10	5 x 2 x 1	17,7	117	370	18
11120CGX062M10	6 x 2 x 1	17,9	135	420	18
11120CGX072M10	7 x 2 x 1	18,5	158	470	18
11120CGX082M10	8 x 2 x 1	19,4	185	520	18
11120CGX102M10	10 x 2 x 1	21,8	230	630	18
11120CGX122M10	12 x 2 x 1	22,5	275	720	18
11120CGX142M10	14 x 2 x 1	24,2	320	830	18
11120CGX162M10	16 x 2 x 1	25,8	365	930	18
11120CGX192M10	19 x 2 x 1	27,9	432	1070	18
11120CGX242M10	24 x 2 x 1	30,8	545	1350	18
11120CGX272M10	27 x 2 x 1	32,8	612	1480	18
11120CGX302M10	30 x 2 x 1	34,4	680	1640	18
11120CGX322M10	32 x 2 x 1	35,8	725	1730	18
11120CGX372M10	37 x 2 x 1	37,8	837	1970	18
11120CGX022M15	2 x 2 x 1,5	14,3	80	290	16
11120CGX032M15	3 x 2 x 1,5	14,9	116	330	16

GAALSHIP® HF 250 ISOS

individually and overall screened, telecommunication and instrumentation cable



ELETTROTEK KABEL® GAALSHIP® HF 250 ISOS

Part no.	No. of pairs/triples x cross section n x mm ²	Outer-Ø ca.mm ± 10%	Copper weight kg/km	Cable weight approx. kg/km	AWG no.*)
11120CGX042M15	4 x 2 x 1,5	16,8	152	390	16
11120CGX052M15	5 x 2 x 1,5	19,3	180	460	16
11120CGX062M15	6 x 2 x 1,5	19,8	205	520	16
11120CGX072M15	7 x 2 x 1,5	20,4	260	590	16
11120CGX082M15	8 x 2 x 1,5	21,4	285	650	16
11120CGX102M15	10 x 2 x 1,5	23,8	368	790	16
11120CGX122M15	12 x 2 x 1,5	24,7	425	920	16
11120CGX142M15	14 x 2 x 1,5	26,8	513	1050	16
11120CGX162M15	16 x 2 x 1,5	28,3	565	1180	16
11120CGX192M15	19 x 2 x 1,5	30,8	693	1370	16
11120CGX242M15	24 x 2 x 1,5	34,4	845	1710	16
11120CGX272M15	27 x 2 x 1,5	36,3	950	1900	16
11120CGX302M15	30 x 2 x 1,5	37,8	1094	2100	16
11120CGX322M15	32 x 2 x 1,5	39,8	1125	2220	16
11120CGX372M15	37 x 2 x 1,5	41,9	1300	2540	16
11120CGX033M05	3 x 3 x 0,5	13,7	59	250	20
11120CGX043M05	4 x 3 x 0,5	14,3	77	280	20
11120CGX073M05	7 x 3 x 0,5	18,3	131	420	20
11120CGX123M05	12 x 3 x 0,5	22,8	221	650	20
11120CGX033M07	3 x 3 x 0,75	14,3	80	270	19
11120CGX043M07	4 x 3 x 0,75	15,1	104	320	19
11120CGX073M07	7 x 3 x 0,75	19,3	178	480	19
11120CGX123M07	12 x 3 x 0,75	24,4	302	750	19
11120CGX033M10	3 x 3 x 1	15,8	99	340	18
11120CGX043M10	4 x 3 x 1	16,4	136	390	18
11120CGX073M10	7 x 3 x 1	20,8	225	590	18
11120CGX123M10	12 x 3 x 1	26,3	383	930	18
11120CGX033M15	3 x 3 x 1,5	17,3	140	420	16
11120CGX043M15	4 x 3 x 1,5	17,8	185	480	16
11120CGX073M15	7 x 3 x 1,5	22,9	320	750	16
11120CGX123M15	12 x 3 x 1,5	28,8	545	1200	16

Other dimensions and colors available on request.

GAALSHIP® HF 250 ISOS FR

individually and overall screened, telecommunication and instrumentation cable, fire resistant



ELETTROTEK KABEL® GAALSHIP® HF 250 ISOS FR



Construction:

Conductor:	stranded red copper conductor Cl. 2, acc. to IEC 60228, DIN VDE 0295
Insulation:	MICA glass tape + XLPE Halogen free compound acc. to IEC 60092-351, thickness acc. to IEC 60092-376
Stranding:	core laid-up together in pairs/triples/quads
Individual screen:	aluminium/polyester tape with tinned copper stranded drain wire and syntetic tape
Stranding:	laying up of pairs/triples/quads
Overall screen:	aluminium/polyester tape with tinned copper stranded drain wire and syntetic tape
Outer sheath:	Orange (RAL 2003), halogen free thermoplastic compound SHF1 acc. to IEC 60092-359, thickness acc. to IEC 60092-376

Technical data:

Nominal voltage:	150/250 V
Temperature range:	-25°C up to +90°C
Installation temp.:	-5°C
Short circuit temperature:	+250°C
Min. bending radius:	8 x d

Resistance:



Fire resistant acc. to:
IEC 60331



Flame and fire retardant acc. to:
IEC 60332-1-2,
IEC 60332-3-22



Halogen free acc. to:
IEC 60754-1/2



Smoke emission properties acc. to:
IEC 61034-1/2

Features:

Sheathing materials acc. to: IEC 60092-359
 Insulating materials acc. to: IEC 60092-351
 Design guidelines acc. to: IEC 60092-350/376
 Choice and installation of electric cables acc. to: IEC 60092-352
 on request class 5
 on request tinned copper conductor

We have possibility to provide the following Certifications on request:

Det Norske Veritas (DNV)
 Lloyd's Register (LR)
 Germanischer Lloyd (GL)
 Bureau Veritas (BV)
 Registro Italiano Navale (RINA)
 American Bureau of Shipping (ABS)
 Other approvals on request



Available on stock CABLE GLANDS:
see page 404 up to 416 of catalogue.

GAALSHIP® HF 250 ISOS FR

individually and overall screened, telecommunication and instrumentation cable, fire resistant



ELETTROTEK KABEL® GAALSHIP® HF 250 ISOS FR



Part no.	No. of pairs/triples x cross section n x mm ²	Outer-Ø ca.mm ± 10%	Copper weight kg/km	Cable weight approx. kg/km	AWG no.*)
11130CGX022M07	2 x 2 x 0,75	16,4	41	320	19
11130CGX032M07	3 x 2 x 0,75	17,5	59	350	19
11130CGX042M07	4 x 2 x 0,75	19,3	77	400	19
11130CGX052M07	5 x 2 x 0,75	22,4	95	480	19
11130CGX062M07	6 x 2 x 0,75	22,8	113	550	19
11130CGX072M07	7 x 2 x 0,75	23,4	131	590	19
11130CGX082M07	8 x 2 x 0,75	24,4	149	660	19
11130CGX102M07	10 x 2 x 0,75	27,3	186	790	19
11130CGX122M07	12 x 2 x 0,75	28,4	166,5	890	19
11130CGX142M07	14 x 2 x 0,75	30,8	258	1030	19
11130CGX162M07	16 x 2 x 0,75	32,4	221	1150	19
11130CGX192M07	19 x 2 x 0,75	35,5	348	1350	19
11130CGX242M07	24 x 2 x 0,75	39,3	411	1650	19
11130CGX272M07	27 x 2 x 0,75	41,8	491	1850	19
11130CGX302M07	30 x 2 x 0,75	43,7	549	2030	19
11130CGX322M07	32 x 2 x 0,75	45,8	594	2150	19
11130CGX372M07	37 x 2 x 0,75	48,4	671	2450	19
11130CGX022M10	2 x 2 x 1	16,8	50	350	18
11130CGX032M10	3 x 2 x 1	17,9	87	370	18
11130CGX042M10	4 x 2 x 1	19,8	95	440	18
11130CGX052M10	5 x 2 x 1	22,7	117	520	18
11130CGX062M10	6 x 2 x 1	23,8	135	600	18
11130CGX072M10	7 x 2 x 1	23,9	158	650	18
11130CGX082M10	8 x 2 x 1	25,4	185	730	18
11130CGX102M10	10 x 2 x 1	28,3	230	870	18
11130CGX122M10	12 x 2 x 1	29,4	275	980	18
11130CGX142M10	14 x 2 x 1	31,8	320	1140	18
11130CGX162M10	16 x 2 x 1	33,5	365	1280	18
11130CGX192M10	19 x 2 x 1	36,3	432	1480	18
11130CGX242M10	24 x 2 x 1	40,8	545	1850	18
11130CGX272M10	27 x 2 x 1	42,8	612	2050	18
11130CGX302M10	30 x 2 x 1	44,8	680	2250	18
11130CGX322M10	32 x 2 x 1	47,4	725	2380	18
11130CGX372M10	37 x 2 x 1	49,8	837	2700	18
11130CGX022M15	2 x 2 x 1,5	17,8	80	400	16
11130CGX032M15	3 x 2 x 1,5	18,8	116	450	16
11130CGX042M15	4 x 2 x 1,5	21,4	152	510	16
11130CGX052M15	5 x 2 x 1,5	24,8	180	620	16
11130CGX062M15	6 x 2 x 1,5	24,8	205	640	16
11130CGX072M15	7 x 2 x 1,5	25,8	260	750	16
11130CGX082M15	8 x 2 x 1,5	26,9	285	870	16
11130CGX102M15	10 x 2 x 1,5	30,8	368	1050	16
11130CGX122M15	12 x 2 x 1,5	31,8	425	1180	16
11130CGX142M15	14 x 2 x 1,5	34,2	513	1350	16
11130CGX162M15	16 x 2 x 1,5	36,5	565	1530	16
11130CGX192M15	19 x 2 x 1,5	39,3	693	1780	16
11130CGX242M15	24 x 2 x 1,5	44,4	845	2220	16
11130CGX272M15	27 x 2 x 1,5	46,4	950	2450	16
11130CGX302M15	30 x 2 x 1,5	48,9	1094	2720	16
11130CGX322M15	32 x 2 x 1,5	51,3	1125	2880	16
11130CGX372M15	37 x 2 x 1,5	53,8	1300	3280	16
11130CGX023M07	3 x 3 x 0,75	19,4	80	430	19
11130CGX043M07	4 x 3 x 0,75	20,3	104	500	19
11130CGX073M07	7 x 3 x 0,75	26,5	178	750	19
11130CGX123M07	12 x 3 x 0,75	33,3	302	1170	19
11130CGX033M10	3 x 3 x 1	19,8	99	460	18
11130CGX043M10	4 x 3 x 1	20,9	136	550	18
11130CGX073M10	7 x 3 x 1	26,8	225	820	18
11130CGX123M10	12 x 3 x 1	34,3	383	1280	18
11130CGX033M15	3 x 3 x 1,5	21,3	140	550	16
11130CGX033M15	4 x 3 x 1,5	22,5	185	640	16
11130CGX073M15	7 x 3 x 1,5	29,3	320	980	16
11130CGX123M15	12 x 3 x 1,5	36,8	545	1560	16

Other dimensions and colors available on request.

GAALSHIP® MARINE CABLES

GAALSHIP® HF 250 ISOSA

individually and overall screened, armoured, telecommunication and instrumentation cable



ELETTROTEK KABEL® GAALSHIP® HF 250 ISOSA



Construction:

Conductor:	stranded red copper conductor Cl. 2, acc. to IEC 60228, DIN VDE 0295
Insulation:	XLPE Halogen free compound acc.to IEC 60092-351, thickness acc. to IEC 60092-376
Stranding:	core laid-up together in pairs/triples/quads
Individual screen:	aluminium/polyester tape with tinned copper stranded drain wire and syntetic tape
Stranding:	laying up of pairs/triples/quads
Overall screen:	aluminium/polyester tape with tinned copper stranded drain wire and syntetic tape
Wrapping:	synthetic tape
Armour:	red copper wires braid acc. to IEC 60092-350
Outer sheath:	Orange (RAL 2003), halogen free thermoplastic compound SHF1 acc. to IEC 60092-359, thickness acc. to IEC 60092-376

Technical data:

Nominal voltage:	150/250 V
Temperature range:	-25°C up to +90°C
<i>Installation temp.:</i>	-5°C
Short circuit temperature:	+250°C
Min. bending radius:	8 x d

Resistance:



Flame and fire retardant acc. to:
IEC 60332-1-2,
IEC 60332-3-22



Halogen free acc. to:
IEC 60754-1/2



Smoke emission properties acc. to:
IEC61034-1/2

Features:

Sheathing materials acc. to: IEC 60092-359
Insulating materials acc. to: IEC 60092-351
Design guidelines acc. to: IEC 60092-350/376
Choice and installation of electric cables acc. to: IEC 60092-352
on request class 5
on request tinned copper conductor
on request tinned copper wire braid armour

We have possibility to provide the following Certifications on request:

Det Norske Veritas (DNV)
Lloyd's Register (LR)
Germanischer Lloyd (GL)
Bureau Veritas (BV)
Registro Italiano Navale (RINA)
American Bureau of Shipping (ABS)
Other approvals on request



Available on stock CABLE GLANDS:
see page 404 up to 416 of catalogue.

GAALSHIP® HF 250 ISOSA

individually and overall screened, armoured, telecommunication and instrumentation cable



ELETTROTEK KABEL® GAALSHIP® HF 250 ISOSA



Part no.	No. of pairs/triples x cross section n x mm ²	Outer-Ø ca.mm ± 10%	Cable weight approx. kg/km	AWG no.)*
11140CGX022M05	2 x 2 x 0,5	12,7	200	20
11140CGX032M05	3 x 2 x 0,5	13,4	230	20
11140CGX042M05	4 x 2 x 0,5	14,6	280	20
11140CGX052M05	5 x 2 x 0,5	16,8	330	20
11140CGX062M05	6 x 2 x 0,5	17,2	380	20
11140CGX072M05	7 x 2 x 0,5	17,5	400	20
11140CGX082M05	8 x 2 x 0,5	18,7	470	20
11140CGX102M05	10 x 2 x 0,5	20,9	580	20
11140CGX122M05	12 x 2 x 0,5	21,8	630	20
11140CGX142M05	14 x 2 x 0,5	22,8	720	20
11140CGX162M05	16 x 2 x 0,5	24,4	790	20
11140CGX192M05	19 x 2 x 0,5	26,3	890	20
11140CGX242M05	24 x 2 x 0,5	28,8	1090	20
11140CGX272M05	27 x 2 x 0,5	30,3	1200	20
11140CGX302M05	30 x 2 x 0,5	31,8	1290	20
11140CGX322M05	32 x 2 x 0,5	33,4	1370	20
11140CGX372M05	37 x 2 x 0,5	34,8	1550	20
11140CGX022M07	2 x 2 x 0,75	13,3	210	19
11140CGX032M07	3 x 2 x 0,75	13,9	250	19
11140CGX042M07	4 x 2 x 0,75	15,4	300	19
11140CGX052M07	5 x 2 x 0,75	18,3	370	19
11140CGX062M07	6 x 2 x 0,75	18,5	420	19
11140CGX072M07	7 x 2 x 0,75	18,9	480	19
11140CGX082M07	8 x 2 x 0,75	19,4	520	19
11140CGX102M07	10 x 2 x 0,75	21,7	620	19
11140CGX122M07	12 x 2 x 0,75	22,8	700	19
11140CGX142M07	14 x 2 x 0,75	24,3	790	19
11140CGX162M07	16 x 2 x 0,75	25,8	900	19
11140CGX192M07	19 x 2 x 0,75	27,3	1000	19
11140CGX242M07	24 x 2 x 0,75	30,3	1200	19
11140CGX272M07	27 x 2 x 0,75	31,8	1320	19
11140CGX302M07	30 x 2 x 0,75	33,2	1430	19
11140CGX322M07	32 x 2 x 0,75	34,9	1520	19
11140CGX372M07	37 x 2 x 0,75	36,8	1710	19
11140CGX022M10	2 x 2 x 1	14,2	250	18
11140CGX032M10	3 x 2 x 1	14,8	300	18
11140CGX042M10	4 x 2 x 1	16,3	360	18
11140CGX052M10	5 x 2 x 1	19,3	450	18
11140CGX062M10	6 x 2 x 1	19,5	500	18
11140CGX072M10	7 x 2 x 1	19,8	580	18
11140CGX082M10	8 x 2 x 1	20,8	620	18
11140CGX102M10	10 x 2 x 1	23,4	760	18
11140CGX122M10	12 x 2 x 1	24,3	840	18
11140CGX142M10	14 x 2 x 1	25,8	950	18
11140CGX162M10	16 x 2 x 1	27,4	1080	18
11140CGX192M10	19 x 2 x 1	29,3	1200	18
11140CGX242M10	24 x 2 x 1	32,4	1500	18
11140CGX272M10	27 x 2 x 1	34,5	1630	18
11140CGX302M10	30 x 2 x 1	35,8	1780	18
11140CGX322M10	32 x 2 x 1	37,8	1880	18
11140CGX372M10	37 x 2 x 1	39,4	2130	18
11140CGX022M15	2 x 2 x 1,5	15,8	310	16
11140CGX032M15	3 x 2 x 1,5	16,8	390	16
11140CGX042M15	4 x 2 x 1,5	18,3	470	16
11140CGX052M15	5 x 2 x 1,5	21,3	550	16
11140CGX062M15	6 x 2 x 1,5	21,5	630	16
11140CGX072M15	7 x 2 x 1,5	21,9	710	16
11140CGX082M15	8 x 2 x 1,5	22,8	780	16
11140CGX102M15	10 x 2 x 1,5	25,4	920	16
11140CGX122M15	12 x 2 x 1,5	26,8	1050	16
11140CGX142M15	14 x 2 x 1,5	28,4	1190	16
11140CGX162M15	16 x 2 x 1,5	30,3	1320	16
11140CGX192M15	19 x 2 x 1,5	32,4	1510	16

GAALSHIP® MARINE CABLES

GAALSHIP® HF 250 ISOSA

individually and overall screened, armoured, telecommunication and instrumentation cable



ELETTROTEK KABEL® GAALSHIP® HF 250 ISOSA FR

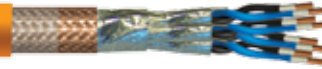

Part no.	No. of pairs/triples x cross section n x mm ²	Outer-Ø ca.mm ± 10%	Cable weight approx. kg/km	AWG no.)*
11140CGX242M15	24 x 2 x 1,5	35,8	1850	16
11140CGX272M15	27 x 2 x 1,5	37,7	2050	16
11140CGX302M15	30 x 2 x 1,5	39,8	2260	16
11140CGX322M15	32 x 2 x 1,5	42,3	2420	16
11140CGX372M15	37 x 2 x 1,5	43,8	2850	16
11140CGX033M05	3 x 3 x 0,5	14,9	280	20
11140CGX043M05	4 x 3 x 0,5	15,8	330	20
11140CGX073M05	7 x 3 x 0,5	19,8	550	20
11140CGX123M05	12 x 3 x 0,5	24,8	810	20
11140CGX033M07	3 x 3 x 0,75	15,8	300	19
11140CGX043M07	4 x 3 x 0,75	16,8	350	19
11140CGX073M07	7 x 3 x 0,75	20,9	600	19
11140CGX123M07	12 x 3 x 0,75	25,7	900	19
11140CGX033M10	3 x 3 x 1	16,9	370	18
11140CGX043M10	4 x 3 x 1	17,8	470	18
11140CGX073M10	7 x 3 x 1	22,5	720	18
11140CGX123M10	12 x 3 x 1	27,9	1080	18
11140CGX033M15	3 x 3 x 1,5	18,3	490	16
11140CGX043M15	4 x 3 x 1,5	19,4	570	16
11140CGX073M15	7 x 3 x 1,5	24,5	870	16
11140CGX123M15	12 x 3 x 1,5	30,2	1350	16

Other dimensions and colors available on request.

GAALSHIP® HF 250 ISOSA FR

individually and overall screened, armoured,
telecommunication and instrumentation cable, fire resistant



ELETTROTEK KABEL® GAALSHIP® HF 250 ISOSA FR



Construction:

Conductor:	stranded red copper conductor Cl. 2, acc. to IEC 60228, DIN VDE 0295
Insulation:	MICA glass tape + XLPE Halogen free compound acc. to IEC 60092-351, thickness acc. to IEC 60092-376
Stranding:	core laid-up together in pairs/triples/ quads
Individual screen:	aluminium/polyester tape with tinned copper stranded drain wire and syntetic tape
Stranding:	laying up of pairs/triples/quads
Overall screen:	aluminium/polyester tape with tinned copper stranded drain wire and syntetic tape
Wrapping:	synthetic tape
Armour:	red copper wires braid acc. to IEC 60092-350
Outer sheath:	Orange (RAL 2003), halogen free thermoplastic compound SHF1 acc. to IEC 60092-359, thickness acc. to IEC 60092-376

Technical data:

Nominal voltage:	150/250 V
Temperature range:	-25°C up to +90°C
Installation temp.:	-5°C
Short circuit temperature:	+250°C
Min. bending radius:	8 x d

Resistance:



Fire resistant acc. to:
IEC 60331



Flame and fire retardant acc. to:
IEC 60332-1-2,
IEC 60332-3-22



Halogen free acc. to:
IEC 60754-1/2



Smoke emission properties acc. to:
IEC61034-1/2

Features:

Sheathing materials acc. to: IEC 60092-359
Insulating materials acc. to: IEC 60092-351
Design guidelines acc. to: IEC 60092-350/376
Choice and installation of electric cables acc. to: IEC 60092-352
on request class 5

on request tinned copper conductor
on request tinned copper wire braid armour

We have possibility to provide the following Certifications on request:

- Det Norske Veritas (DNV)
- Lloyd's Register (LR)
- Germanischer Lloyd (GL)
- Bureau Veritas (BV)
- Registro Italiano Navale (RINA)
- American Bureau of Shipping (ABS)
- Other approvals on request



Available on stock CABLE GLANDS:
see page 404 up to 416 of catalogue.

GAALSHIP® MARINE CABLES

GAALSHIP® HF 250 ISOSA FR

individually and overall screened, armoured, telecommunication and instrumentation cable, fire resistant



ELETTROTEK KABEL® GAALSHIP® HF 250 ISOSA FR



Part no.	No. of pairs/triples x cross section n x mm ²	Outer-Ø ca.mm ± 10%	Cable weight approx. kg/km	AWG no.*)
11150CGX022M07	2 x 2 x 0,75	16,8	230	19
11150CGX032M07	3 x 2 x 0,75	17,8	280	19
11150CGX042M07	4 x 2 x 0,75	20,5	340	19
11150CGX052M07	5 x 2 x 0,75	23,2	420	19
11150CGX062M07	6 x 2 x 0,75	23,5	470	19
11150CGX072M07	7 x 2 x 0,75	23,5	550	19
11150CGX082M07	8 x 2 x 0,75	25,4	590	19
11150CGX102M07	10 x 2 x 0,75	28,3	710	19
11150CGX122M07	12 x 2 x 0,75	29,3	800	19
11150CGX142M07	14 x 2 x 0,75	31,3	900	19
11150CGX162M07	16 x 2 x 0,75	33,5	1020	19
11150CGX192M07	19 x 2 x 0,75	35,3	1150	19
11150CGX242M07	24 x 2 x 0,75	39,8	1400	19
11150CGX272M07	27 x 2 x 0,75	41,4	1550	19
11150CGX302M07	30 x 2 x 0,75	43,8	1680	19
11150CGX322M07	32 x 2 x 0,75	46,3	1780	19
11150CGX372M07	37 x 2 x 0,75	48,8	2020	19
11150CGX022M10	2 x 2 x 1	17,8	280	18
11150CGX032M10	3 x 2 x 1	19,3	350	18
11150CGX042M10	4 x 2 x 1	21,4	420	18
11150CGX052M10	5 x 2 x 1	24,3	510	18
11150CGX062M10	6 x 2 x 1	24,8	590	18
11150CGX072M10	7 x 2 x 1	25,3	680	18
11150CGX082M10	8 x 2 x 1	26,5	730	18
11150CGX102M10	10 x 2 x 1	29,4	900	18
11150CGX122M10	12 x 2 x 1	30,8	1010	18
11150CGX142M10	14 x 2 x 1	32,8	1150	18
11150CGX162M10	16 x 2 x 1	34,8	1300	18
11150CGX192M10	19 x 2 x 1	37,4	1470	18
11150CGX242M10	24 x 2 x 1	41,8	1810	18
11150CGX272M10	27 x 2 x 1	44,4	1990	18
11150CGX302M10	30 x 2 x 1	46,3	2170	18
11150CGX322M10	32 x 2 x 1	49,5	2300	18
11150CGX372M10	37 x 2 x 1	51,3	2600	18
11150CGX022M15	2 x 2 x 1,5	19,3	340	16
11150CGX032M15	3 x 2 x 1,5	20,2	450	16
11150CGX042M15	4 x 2 x 1,5	22,8	550	16
11150CGX052M15	5 x 2 x 1,5	26,2	640	16
11150CGX062M15	6 x 2 x 1,5	26,5	720	16
11150CGX072M15	7 x 2 x 1,5	26,8	810	16
11150CGX082M15	8 x 2 x 1,5	28,3	900	16
11150CGX102M15	10 x 2 x 1,5	31,7	1070	16
11150CGX122M15	12 x 2 x 1,5	33,3	1230	16
11150CGX142M15	14 x 2 x 1,5	35,4	1400	16
11150CGX162M15	16 x 2 x 1,5	37,8	1550	16
11150CGX192M15	19 x 2 x 1,5	40,3	1800	16
11150CGX242M15	24 x 2 x 1,5	45,8	2200	16
11150CGX272M15	27 x 2 x 1,5	48,4	2430	16
11150CGX302M15	30 x 2 x 1,5	50,5	2700	16
11150CGX322M15	32 x 2 x 1,5	53,4	2880	16
11150CGX372M15	37 x 2 x 1,5	55,3	3400	16

GAALSHIP® MARINE CABLES

GAALSHIP® HF 250 ISOSA FR

individually and overall screened, armoured, telecommunication and instrumentation cable, fire resistant



ELETTROTEK KABEL® GAALSHIP® HF 250 ISOSA FR

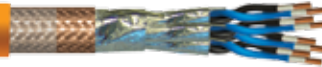

Part no.	No. of cores x cross section n x mm ²	Outer-Ø ca.mm ± 10%	Cable weight approx. kg/km	AWG no.*)
11150CGX033M07	3 x 3 x 0,75	20,3	350	19
11150CGX043M07	4 x 3 x 0,75	21,5	400	19
11150CGX073M07	7 x 3 x 0,75	26,8	680	19
11150CGX123M07	12 x 3 x 0,75	33,8	1050	19
11150CGX033M10	3 x 3 x 1	21,4	430	18
11150CGX043M10	4 x 3 x 1	22,3	550	18
11150CGX073M10	7 x 3 x 1	28,2	870	18
11150CGX122M10	12 x 3 x 1	35,5	1320	18
11150CGX033M15	3 x 3 x 1,5	22,8	570	16
11150CGX043M15	4 x 3 x 1,5	23,8	650	16
11150CGX073M15	7 x 3 x 1,5	30,2	1020	16
11150CGX123M15	12 x 3 x 1,5	38,5	1600	16

Other dimensions and colors available on request.

GAALSHIP® MEDIUM SHF...

1,8/3 kV up to 12/20 kV, armoured medium voltage power cable, single core



Construction:

Conductor:	flexible tinned copper conductor Cl. 5*, acc to IEC 60228 *Cl. 2 for electrical resistance
Conductor screen:	semi-conducting tape + extruded semi-conductive compound (from 3,6 up to 12/20 kV)
Insulation:	XLPE halogen free compound acc. to IEC 60092-351
Insulation screen:	extruded semi-conductive compound (from 3,6 up to 12/20 kV)
Screen:	red copper tapes (from 3,6 up to 12/20 kV)
Inner sheath:	halogen-free type SHF1
Armour:	red copper wires braid acc. to IEC 60092-350
Outer sheath:	red (RAL 3000), Halogen-free type SHF1 acc. to IEC 60092-359

Technical data:

Nominal voltage:	1,8/3 kV to 12/20 kV
Temperature range:	-25°C up to +90°C
Installation temp.:	-5°C
Short circuit temperature:	+250°C
Min. bending radius:	4 x d

Resistance:



Flame and fire retardant acc. to:
IEC 60332-1-2,
IEC 60332-3-22



Halogen free acc. to:
IEC 60754-1/2



Smoke emission properties acc. to:
IEC61034-1/2

Features:

Other standard acc. to:
IEC 60092-350/353/354, IEC 60092-352, IEC 60092-351
IEC 60092-359

- on request red copper conductor
- on request EPR or EPDM rubber compound
- on request tinned copper wires braid armouring
- on request black or gray outer sheath only for 1,8/3 kV

We have possibility to provide the following Certifications on request:

- Det Norske Veritas (DNV)
- Lloyd's Register (LR)
- Germanischer Lloyd (GL)
- Bureau Veritas (BV)
- Registro Italiano Navale (RINA)
- American Bureau of Shipping (ABS)
- Other approvals on request
- CSA C.22.2 Abnormal low temperature performances (-40°C when required only)



Available on stock CABLE GLANDS:
see page 404 up to 416 of catalogue.

GAALSHIP® MEDIUM SHF...

1,8/3 kV up to 12/20 kV, armoured medium voltage power cable, single core



ELETTROTEK KABEL® GAALSHIP® MEDIUM SHF...

1,8/3 kV

Part no.	No. of cores x cross section n x mm ²	Outer-Ø ca.mm ± 10%	Cable weight approx. kg/km	AWG no.)*
13010KRL010M62	1x16	15,5	410	6
13010KRL010M63	1x25	17,0	530	4
13010KRL010M64	1x35	18,0	640	2
13010KRL010M65	1x50	19,5	790	1
13010KRL010M66	1x70	21,3	1020	2/0
13010KRL010M67	1x95	23,5	1320	3/0
13010KRL010M68	1x120	25,3	1570	4/0
13010KRL010M69	1x150	27,0	1860	250 MCM
13010KRL010M70	1x185	29,5	2270	350 MCM
13010KRL010M71	1x240	32,0	2850	450 MCM
13010KRL010M72	1x300	34,4	3410	550 MCM

3,6/6 kV

Part no.	No. of cores x cross section n x mm ²	Outer-Ø ca.mm ± 10%	Cable weight approx. kg/km	AWG no.)*
13010MRL010M62	1x16	19,5	600	6
13010MRL010M63	1x25	21,0	750	4
13010MRL010M64	1x35	21,8	860	2
13010MRL010M65	1x50	23,5	1010	1
13010MRL010M66	1x70	25,0	1260	2/0
13010MRL010M67	1x95	27,5	1580	3/0
13010MRL010M68	1x120	30,0	1860	4/0
13010MRL010M69	1x150	30,5	2160	250 MCM
13010MRL010M70	1x185	33,4	2590	350 MCM
13010MRL010M71	1x240	36,5	3250	450 MCM
13010MRL010M72	1x300	39,7	3890	550 MCM

6/10 kV

Part no.	No. of cores x cross section n x mm ²	Outer-Ø ca.mm ± 10%	Cable weight approx. kg/km	AWG no.)*
13010QRL010M63	1x25	22,8	820	4
13010QRL010M64	1x35	24,0	950	2
13010QRL010M65	1x50	25,3	1100	1
13010QRL010M66	1x70	27,4	1360	2/0
13010QRL010M67	1x95	29,5	1680	3/0
13010QRL010M68	1x120	31,4	1980	4/0
13010QRL010M69	1x150	36,0	2280	250 MCM
13010QRL010M70	1x185	35,9	2740	350 MCM
13010QRL010M71	1x240	38,2	3360	450 MCM
13010QRL010M72	1x300	41,5	4090	550 MCM
13010MRL010M72	1x300	39,7	3890	550 MCM

GAALSHIP® MARINE CABLES

GAALSHIP® MEDIUM SHF...

1,8/3 kV up to 12/20 kV, armoured medium voltage power cable, single core



ELETTROTEK KABEL® GAALSHIP® MEDIUM SHF...



8,7/15 kV

Part no.	No. of cores x cross section n x mm ²	Outer-Ø ca.mm ± 10%	Cable weight approx. kg/km	AWG no.)*
13010SRL010M63	1x25	25,3	940	4
13010SRL010M64	1x35	26,5	1070	2
13010SRL010M65	1x50	27,7	1230	1
13010SRL010M66	1x70	30,0	1500	2/0
13010SRL010M67	1x95	31,7	1820	3/0
13010SRL010M68	1x120	34,0	2150	4/0
13010SRL010M69	1x150	35,5	2470	250 MCM
13010SRL010M70	1x185	40,0	2910	350 MCM
13010SRL010M71	1x240	41,0	3620	450 MCM
13010SRL010M72	1x300	43,8	4270	550 MCM

12/20 kV

Part no.	No. of cores x cross section n x mm ²	Outer-Ø ca.mm ± 10%	Cable weight approx. kg/km	AWG no.)*
13010URL010M64	1x35	29,5	1180	2
13010URL010M65	1x50	30,5	1370	1
13010URL010M66	1x70	32,5	1620	2/0
13010URL010M67	1x95	34,5	1970	3/0
13010URL010M68	1x120	36,5	2300	4/0
13010URL010M69	1x150	38,5	2600	250 MCM
13010URL010M70	1x185	41,5	3140	350 MCM
13010URL010M71	1x240	43,5	3800	450 MCM
13010URL010M72	1x300	46,5	4460	550 MCM

Other dimensions and colors available on request.

GAALSHIP® MEDIUM MHF...

1,8/3 kV up to 12/20 kV, armoured medium voltage power cable, three cores



ELETTROTEK KABEL® GAALSHIP® MEDIUM MHF...



Construction:

Conductor:	flexible tinned copper conductor Cl. 5*, acc to IEC 60228 *Cl. 2 for electrical resistance
Conductor screen:	semi-conducting tape + extruded semi-conductive compound (from 3,6 up to 12/20 kV)
Insulation:	XLPE halogen free compound acc. to IEC 60092-351
Insulation screen:	extruded semi-conductive compound (from 3,6 up to 12/20 kV)
Screen:	red copper tapes (from 3,6 up to 12/20 kV)
Fillers:	Halogen-free compound
Inner sheath:	halogen-free type SHF1
Armour:	galvanized steel wires braid acc. to IEC 60092-350
Outer sheath:	red (RAL 3000), Halogen-free type SHF1 acc. to IEC 60092-359

Technical data:

Nominal voltage:	1,8/3 kV to 12/20 kV
Temperature range:	-25°C up to +90°C
Installation temp.:	-5°C
Short circuit temperature:	+250°C
Min. bending radius:	12 x d

Resistance:



Flame and fire retardant acc. to:
IEC 60332-1-2,
IEC 60332-3-22



Halogen free acc. to:
IEC 60754-1/2



Smoke emission properties acc. to:
IEC 61034-1/2

Features:

Other standard acc. to:
IEC 60092-350/353/354, IEC 60092-352, IEC 60092-351
IEC 60092-359

- on request red copper conductor
- on request EPR or EPDM rubber compound
- on request red or tinned copper wires braid armouring
- on request black or gray outer sheath only for 1,8/3 kV

We have possibility to provide the following Certifications on request:

- Det Norske Veritas (DNV)
- Lloyd's Register (LR)
- Germanischer Lloyd (GL)
- Bureau Veritas (BV)
- Registro Italiano Navale (RINA)
- American Bureau of Shipping (ABS)
- Other approvals on request
- CSA C.22.2 Abnormal low temperature performances (-40°C when required only)



**Available on stock CABLE GLANDS:
see page 404 up to 416 of catalogue.**

GAALSHIP® MEDIUM MHF...

1,8/3 kV up to 12/20 kV, armoured medium voltage power cable, three cores



ELETTROTEK KABEL® GAALSHIP® MEDIUM MHF...



1,8/3 kV

Part no.	No. of cores x cross section n x mm ²	Outer-Ø ca.mm ± 10%	Cable weight approx. kg/km	AWG no.*)
13020KR1030M62	3x16	30,2	1340	6
13020KR1030M63	3x25	32,0	1770	4
13020KR1030M64	3x35	34,0	2160	2
13020KR1030M65	3x50	37,5	2710	1
13020KR1030M66	3x70	41,5	3530	2/0
13020KR1030M67	3x95	46,8	4700	3/0
13020KR1030M68	3x120	51,1	5730	4/0
13020KR1030M69	3x150	54,2	6720	250 MCM
13020KR1030M70	3x185	60,2	8280	350 MCM
13020KR1030M71	3x240	65,8	10390	450 MCM
13020KR1030M72	3x300	71,3	12510	550 MCM

3,6/6 kV

Part no.	No. of cores x cross section n x mm ²	Outer-Ø ca.mm ± 10%	Cable weight approx. kg/km	AWG no.*)
13020MR1030M62	3x16	37,5	2140	6
13020MR1030M63	3x25	41,0	2730	4
13020MR1030M64	3x35	43,1	3180	2
13020MR1030M65	3x50	46,5	3790	1
13020MR1030M66	3x70	50,8	4740	2/0
13020MR1030M67	3x95	55,7	5950	3/0
13020MR1030M68	3x120	60,0	7060	4/0
13020MR1030M69	3x150	63,3	8170	250 MCM
13020MR1030M70	3x185	68,8	9770	350 MCM
13020MR1030M71	3x240	75,1	12140	450 MCM
13020MR1030M72	3x300	82,5	14770	550 MCM

6/10 kV

Part no.	No. of cores x cross section n x mm ²	Outer-Ø ca.mm ± 10%	Cable weight approx. kg/km	AWG no.*)
13020QR1030M62	3x16	42,5	2640	6
13020QR1030M63	3x25	45,5	3170	4
13020QR1030M64	3x35	48,0	3670	2
13020QR1030M65	3x50	51,0	4290	1
13020QR1030M66	3x70	55,5	5290	2/0
13020QR1030M67	3x95	60,8	6600	3/0
13020QR1030M68	3x120	64,5	7690	4/0
13020QR1030M69	3x150	67,5	8770	250 MCM
13020QR1030M70	3x185	73,4	10480	350 MCM
13020QR1030M71	3x240	79,5	12880	450 MCM
13020QR1030M72	3x300	85,8	15380	550 MCM

GAALSHIP® MEDIUM MHF...

1,8/3 kV up to 12/20 kV, armoured medium voltage power cable, three cores



ELETTROTEK KABEL® GAALSHIP® MEDIUM MHF...



8,7/15 kV

Part no.	No. of cores x cross section n x mm ²	Outer-Ø ca.mm ± 10%	Cable weight approx. kg/km	AWG no.)*
13020SR1030M63	3x25	51,0	3880	4
13020SR1030M64	3x35	53,4	4290	2
13020SR1030M65	3x50	56,4	4940	1
13020SR1030M66	3x70	60,9	6010	2/0
13020SR1030M67	3x95	65,8	7300	3/0
13020SR1030M68	3x120	69,7	8430	4/0
13020SR1030M69	3x150	72,5	9570	250 MCM
13020SR1030M70	3x185	79,2	11510	350 MCM
13020SR1030M71	3x240	84,4	13770	450 MCM
13020SR1030M72	3x300	91,0	16380	550 MCM

12/20 kV

Part no.	No. of cores x cross section n x mm ²	Outer-Ø ca.mm ± 10%	Cable weight approx. kg/km	AWG no.)*
13020UR1030M64	3x35	59,4	4970	2
13020UR1030M65	3x50	62,4	5670	1
13020UR1030M66	3x70	66,3	6650	2/0
13020UR1030M67	3x95	71,3	7950	3/0
13020UR1030M68	3x120	75,4	9270	4/0
13020UR1030M69	3x150	78,4	10510	250 MCM
13020UR1030M70	3x185	84,5	12260	350 MCM
13020UR1030M71	3x240	90,4	14760	450 MCM
13020UR1030M72	3x300	86,4	17330	550 MCM

Other dimensions and colors available on request.

Max. DC resistance at 20°C acc. to IEC 60228

Tinned conductors

Cross-section x mm ²	Cl. 2 Ohm/km	Cl. 5 Ohm/km	Cross section mm ²	Cl. 2 Ohm/km	Cl. 5 Ohm/km
1	18,2	20,0	70	0,270	0,277
1,5	12,2	13,7	95	0,195	0,210
2,5	7,56	8,21	120	0,154	0,164
4	4,70	5,09	150	0,126	0,132
6	3,11	3,39	185	0,100	0,108
10	1,84	1,95	240	0,0762	0,0817
16	1,16	1,24	300	0,0607	0,0654
25	0,734	0,795	400	0,0475	0,0495
35	0,529	0,565	500	0,0396	0,0391
50	0,391	0,393	630	0,0286	0,0292

Red conductor

Cross-section x mm ²	Cl. 2 Ohm/km	Cl. 5 Ohm/km	Cross section mm ²	Cl. 2 Ohm/km	Cl. 5 Ohm/km
1	18,1	19,5	70	0,268	0,272
1,5	12,1	13,3	95	0,193	0,206
2,5	7,41	7,98	120	0,153	0,161
4	4,61	4,95	150	0,124	0,129
6	3,08	3,30	185	0,0991	0,106
10	1,83	1,91	240	0,0754	0,0801
16	1,15	1,21	300	0,0601	0,0641
25	0,727	0,780	400	0,0470	0,0486
35	0,524	0,554	500	0,0366	0,0384
50	0,387	0,387	630	0,0283	0,0287

Derating factors for various ambient air temperature acc. to IEC 60092-352

Temp.	35°	40°	45°	50°	55°	60°	65°	70°	75°	80°
cf.	1,10	1,05	1,00	0,94	0,88	0,82	0,74	0,67	0,58	0,47

Current rating for continuous service

max. temp. on conductor 90°C, max. ambient temperature + 45°C, acc. to IEC 60092-352

Cores	1	2	3	4	5	7	12	19	27	37
Reduction	1	0,85	0,70	0,70	0,58	0,52	0,44	0,37	0,33	0,30
mm ²	(A)	(A)	(A)	(A)	(A)	(A)	(A)	(A)	(A)	(A)
1,5	23	20	16	16	13	12	10	9	8	7
2,5	30	26	21	21	18	16	13	11	10	9
4	41	34	28	28	24					
6	52	44	36	36	30					
10	72	61	50	50	42					
16	96	82	67	67	56					
25	127	108	89	89	74					
35	157	133	110	110	92					
50	196	167	137	137						
70	242	206	169	169						
95	293	249	205	205						
120	339	288	237	237						
150	389	331	272	272						
185	444	377	311	311						
240	522	444	365	365						
300	601	511	421	421						

Short circuit current starting temperature 90°C, final temperature 250°C

Cross-section x mm ²	1 sec. A	0,5 sec. A	0,2 sec. A	Cross-section x mm ²	1 sec. A	0,5 sec. A	0,2 sec. A
1	143	202	320	70	10010	14156	22383
1,5	215	303	480	95	13585	19212	30377
2,5	358	506	799	120	17160	24268	38371
4	572	809	1279	150	21450	30335	47964
6	858	1213	1919	185	26455	37413	59155
10	1430	2022	3198	240	34320	48536	76742
16	2288	3236	5116	300	42900	60670	95927
25	3575	5056	7994	400	57200	80893	127903
35	5005	7078	11192	500	71500	101116	159879
50	7150	10112	15988	600	90090	127406	201447





“NEK” Normatives

INTRODUCTION

Each offshore platform has to reconcile a vast and integrated system of control, communication, power and instrumentation with both human safety and the environment, in spite of the hard working conditions.

A strong cooperation with the most important Oil & Gas Players together with the highest production technologies and advanced materials gave birth to the GAALSHIP Offshore Cables.

These cables solutions fit to all the offshore application like Drilling Ship, FPSO, FPO, FSU, Topside and also to products for processing, upstream and downstream, land based power generation and marine uses.

We work with the most important Brands of Offshore cables Producers, approved by the following Certification Authorities:

Det Norske Veritas (DNV)

Lloyd's Register (LR)

Bureau Veritas (BV)

Registro Italiano Navale (RINA)

American Bureau of Shipping (ABS)

Transport Canada

UL listed as marine shipboard cables

CSA listed as marine shipboard cables

“NEK” normatives

GAALSHIP® OFFSHORE cables according to:

NEK 606 IIII ED.:2009	Cables for offshore installations halogen free and/or MUD resistant.
IEC 60092-350:	General construction and test requirement.
IEC 60092-351:	Insulating materials for shipboard power cables.
IEC 60092-352:	Choice and installation of electric cables.
IEC 60092-353:	Single and multicore cables with extruded solid insulation for rated voltages 0.6/1 and 1.8/3 kV.
IEC 60092-354:	Single and three-core power cables with extruded solid insulation for rated voltages 6 and 30 kV.
IEC 60092-359:	Sheating materials for shipboard power cables.
IEC 60092-376 (2003-05):	150/250 V cables for control and instrumentation circuits.
IEC 60228:	Conductors of insulated cables.
IEC 60331 :	Fire resisting characteristics of electrical cables.
IEC 60332-1-2:	Test on a single vertical insulated wire or cable.
IEC 60332-3-22:	Test on bunched wires or cables.
IEC 60754-1/60754-2:	Test on gases evolved during combustion of materials from cable.
IEC 60811:	Common test methods for insulating and sheating materials of electric cables.
IEC 61034-1/61034-2:	Measurements of smoke density of electric cable burning under defined conditions.

Legend:

(acc. to NEK)

Materials	Insulation	Wrapping/ Inner sheath	Armour/Screen	Outer sheath
fire resisting tape(s)+insulation (H.F.)	B			
Ethylene propylene rubber (EPR)	R			
Cross linked polyethylene (XLPE)	T			
Halogen free thermosetting compound	U			
Bedding or taping (H.F.)		F		
No armour			X	
Copper wire braid (tinned or bare)			O	
Galvanized steel wire braid			C	
Thermoplastic compound (H.F.) SHF1			I	I
Halogen free thermosetting comp. SHF2				U
Halogen free thermosetting comp. SHF+MUD				U

Cores identification:

Insulation colour scheme:

0,6/1 kV Power and control cables

According to NEK 606 III ed.: 2009 (traditional cores color):

1 core	Off - White (grey)
2 cores	Off - White (grey) - black
3 cores	Off - White (grey) - black - red
4 cores	Off - White (grey) - black - red - blue
Above 4 cores	Black numbers on white base
earthing core	Green/Yellow

According to standard HD 308 S2 and NEK 606 III ed.: 2009:

Insulated cores with Green/Yellow:

2 cores	-	-			
3 cores	Green/Yellow	Blue	Brown		
4 cores	Green/Yellow	-	Brown	Black	Grey
5 cores	Green/Yellow	Blue	Brown	Black	Grey

Insulated cores without Green/Yellow

2 cores	Blue	Brown			
3 cores	-	Brown	Black	Grey	
4 cores	Blue	Brown	Black	Grey	
5 cores	Blue	Brown	Black	Grey	Black

150/250 V Instrumentation cables

N. of cores Cores colour

Pair Black - Light Blue

Triple Black - Light Blue - Brown

Pairs/Triples are numbered with numbers printed directly on the insulated conductors (1-1; 2-2; ...) or buy numbered tape

Other colours available on request

MV cables

1x...: natural colour of the compound

3x...: Coloured tape or thread (e.g.: white - black - red)

Outer sheath colours (STANDARDS COLOURS)

Instrumentation and control	GREY
Power LV	BLACK
Power MV	RED

Other colours available on request



GAALSHIP® RU
P18 or P18+MUD 0,6/1 kV.



ELETTROTEK KABEL® GAALSHIP® RU



Construction:

Conductor:	stranded tinned copper conductor Cl. 2, acc to IEC 60228
Insulation:	HR-EPR acc. to IEC 60092-351, thickness acc. to IEC 60092-353
Cores color:	acc. to NEK on request HD 308 S2
Outer sheath:	black (RAL 9005), halogen-free mud resistant thermosetting type SHF MUD, acc. to NEK IIII ed. 2009. Thickness acc. to IEC 60092-353

Technical data:

Nominal voltage:	0,6/1 kV
Temperature range:	- 40°C up to +90°C
<i>Installation temp.:</i>	- 20 °C
Short circuit temperature:	+250°C
Min. bending radius:	D < 25mm: = 4 x D D > 25 mm: = 6 x D

Resistance:



Flame and fire retardant acc. to:
IEC 60332-1-2,
IEC 60332-3-22



Halogen free acc. to:
IEC 60754-1



Smoke emission properties acc. to:
IEC 61034-2

Features:

Sheathing materials acc. to: IEC 60092-359
Insulating materials acc. to: IEC 60092-351
Design guidelines acc. to: IEC 60092-350-353
Choice and installation of electric cables acc. to: IEC 60092-352 on request class 5
on request halogen free thermosetting type SHF2 outer sheath, acc. to IEC 60092-359 and CSA 22.2 n.38-95 cold bend-impact test at low temperature (-40°C)

acc. to NEK 606 IIII ed. 2009,
Halogen free & MUD resistance cables,
for the marine, ship and offshore

We have possibility to provide the following Certifications on request:

Det Norske Veritas (DNV)

Lloyd's Register (LR)



Available on stock CABLE GLANDS:
see page 404 up to 416 of catalogue.

GAALSHIP® OFFSHORE CABLES

GAALSHIP® RU

P18 or P18+MUD 0,6/1 kV.



CE

ELETTROTEK KABEL® GAALSHIP® RU



Part no.	No. of cores x cross section n x mm ²	Outer-Ø ca. mm ± 10%	Copper weight kg/km	Cable weight approx. kg/km	AWG no. *)
15020G7E010M61	1x10	8,5	96	175	8
15020G7E010M62	1x16	9,8	153,6	245	6
15020G7E010M63	1x25	11,7	240	365	4
15020G7E010M64	1x35	12,8	336	465	2
15020G7E010M65	1x50	14,4	480	605	1
15020G7E010M66	1x70	16,3	672	815	2/0
15020G7E010M67	1x95	18,7	912	1100	3/0
15020G7E010M68	1x120	20,3	1152	1355	4/0
15020G7E010M69	1x150	22,4	1440	1645	250 MCM
15020G7E010M70	1X185	24,9	1776	2085	350 MCM
15020G7E010M71	1x240	28,1	2304	2670	450 MCM
15020G7E010M72	1x300	30,8	2880	3440	550 MCM
15020G7E020M15	2x1,5	9,7	28,8	155	16
15020G7E020M25	2x2,5	10,5	48	185	14
15020G7E020M40	2x4	11,6	76,8	235	12
15020G7E020M60	2x6	12,9	115,2	305	10
15020G7E020M61	2x10	14,8	192	430	8
15020G7E020M62	2x16	17,2	307,2	615	6
15020G7E020M63	2x25	21,3	480	950	4
15020G7E020M64	2x35	23,3	672	1195	2
15020G7E020M65	2x50	26,9	960	1595	1
15020G7E030M15	3x1,5	10,3	43,2	175	16
15020G7E030M25	3x2,5	11,1	720	215	14
15020G7E030M40	3x4	12,5	115,2	290	12
15020G7E030M60	3x6	13,6	172,8	370	10
15020G7E030M61	3x10	16	288	540	8
15020G7E030M62	3x16	18,5	460,8	780	6
15020G7E030M63	3x25	22,9	720	1210	4
15020G7E030M64	3x35	25	1008	1535	2
15020G7E030M65	3x50	28,7	1440	2040	1
15020G7E030M66	3x70	32,6	2016	2775	2/0
15020G7E030M67	3x95	37,6	2736	3755	3/0
15020G7E030M68	3x120	41,2	3456	4650	4/0
15020G7E030M69	3x150	45,7	4320	5685	250 MCM
15020G7E030M70	3x185	51,2	5328	7210	350 MCM
15020G7E030M71	3x240	57,5	6912	9310	450 MCM
15020G7E040M15	4x1,5	11,2	57,6	210	16
15020G7E040M25	4x2,5	12,4	96	265	14
15020G7E040M40	4x4	13,7	153,6	350	12
15020G7E040M60	4x6	15,2	230,4	465	10
15020G7E040M61	4x10	17,5	384	675	8
15020G7E040M62	4x16	20,4	614,4	980	6
15020G7E040M63	4x25	25,5	960	1540	4
15020G7E040M64	4x35	27,8	1344	1965	2
15020G7E040M65	4x50	31,9	1920	2610	1
15020G7E040M66	4x70	36,3	2688	3550	2/0
15020G7E040M67	4x95	42	3648	4825	3/0
15020G7E040M68	4x120	46	4608	5975	4/0
15020G7E050M15	5x1,5	12,5	72	255	16
15020G7E070M15	7x1,5	13,5	100,8	310	16
15020G7E120M15	12x1,5	18,1	172,8	495	16
15020G7E190M15	19x1,5	21,4	273,6	725	16
15020G7E270M15	27x1,5	25,8	388,8	995	16
15020G7E370M15	37x1,5	29,3	532,8	1325	16
15020G7E050M25	5x2,5	13,5	120	315	14
15020G7E070M25	7x2,5	14,9	168	400	14
15020G7E120M25	12x2,5	19,8	288	635	14
15020G7E190M25	19x2,5	23,6	456	945	14
15020G7E270M25	27x2,5	28,4	648	1305	14
15020G7E370M25	37x2,5	32,3	888	1740	14

Other dimensions and colors available on request.

GAALSHIP® RFOU

PI or PI/P8 0,6/1 kV.



ELETTROTEK KABEL® GAALSHIP® RFOU



Construction:

Conductor:	stranded tinned copper conductor Cl. 2, acc to IEC 60228
Insulation:	EPR acc. to IEC 60092-351
Cores color:	acc. to NEK on request HD 308 S2
Inner sheath:	halogen-free compound, indicative thickness acc. to IEC 60092-353
Armouring:	tinned copper wires braid acc. to IEC 60092-350, IEC 60092-352 used as earth conductor
Outer sheath:	black (RAL 9005), halogen-free mud resistant thermosetting type SHF MUD, acc. to NEK IIII ed. 2009. Thickness acc. to IEC 60092-353

Technical data:

Nominal voltage:	0,6/1 kV
Temperature range:	- 40°C up to +90°C
Installation temp.:	- 20 °C
Short circuit temperature:	+250°C
Min. bending radius:	$D < any\ r = 4 \times D$

Resistance:



Flame and fire retardant acc. to:
IEC 60332-1-2,
IEC 60332-3-22



Halogen free acc. to:
IEC 60754-1



Smoke emission properties acc. to:
IEC 61034-2

Features:

Sheathing materials acc. to: IEC 60092-359
Insulating materials acc. to: IEC 60092-351
Design guidelines acc. to: IEC 60092-350-353
Choice and installation of electric cables acc. to: IEC 60092-352
on request class 5

on request halogen free thermosetting type SHF2 outer sheath, acc. to IEC 60092-359 and CSA 22.2 n.38-95 cold bend-impact test at low temperature (-40°C)

acc. to NEK 606 IIII ed. 2009,
Halogen free & MUD resistance cables,
for the marine, ship and offshore

We have possibility to provide the following Certifications on request:

Det Norske Veritas (DNV)

Lloyd's Register (LR)



Available on stock CABLE GLANDS:
see page 404 up to 416 of catalogue.

GAALSHIP® OFFSHORE CABLES

GAALSHIP® RFOU

PI or PI/P8 0,6/1 kV.



ELETTROTEK KABEL® GAALSHIP® RFOU

Part no.	No. of cores x cross section n x mm ²	Ø under armour ca. mm ± 10%	Outer-Ø ca. mm ± 10%	Cable weight approx. kg/km	AWG no. *)
15040G7E010M61	1x10	8,7	12,2	305	8
15040G7E010M62	1x16	9,8	13,5	395	6
15040G7E010M63	1x25	11,7	15,4	535	4
15040G7E010M64	1x35	12,6	16,9	695	2
15040G7E010M65	1x50	14,2	18,7	880	1
15040G7E010M66	1x70	15,9	20,4	1115	2/0
15040G7E010M67	1x95	18,1	22,8	1445	3/0
15040G7E010M68	1x120	19,9	24,9	1755	4/0
15040G7E010M69	1x150	21,8	26,8	2065	250 MCM
15040G7E010M70	1x185	24,1	29,3	2570	350 MCM
15040G7E010M71	1x240	27,1	32,5	3200	450 MCM
15040G7E010M72	1x300	29,6	35,2	3945	550 MCM
15040G7E020M15	2x1,5/4	9,9	13,6	305	16
15040G7E020M25	2x2,5/4	10,7	14,4	345	14
15040G7E020M40	2x4/4	11,8	16,1	455	12
15040G7E020M60	2x6/6	12,8	17,1	530	10
15040G7E020M61	2x10/10	14,8	19,3	690	8
15040G7E020M62	2x16/16	17	21,7	965	6
15040G7E020M63	2x25/16	20,9	25,9	1345	4
15040G7E020M64	2x35/16	22,7	27,9	1605	2
15040G7E020M65	2x50/25	26,1	31,9	2260	1
15040G7E030M15	3x1,5/4	10,5	14,2	330	16
15040G7E030M25	3x2,5/4	11,3	15,6	425	14
15040G7E030M40	3x4/6	12,5	16,8	510	12
15040G7E030M60	3x6/6	13,6	18,1	615	10
15040G7E030M61	3x10/10	15,8	20,3	805	8
15040G7E030M62	3x16/16	18,1	22,8	1135	6
15040G7E030M63	3x25/16	22,5	27,5	1630	4
15040G7E030M64	3x35/16	24,4	29,6	1965	2
15040G7E030M65	3x50/25	27,9	33,9	2740	1
15040G7E030M66	3x70/35	31,6	38,4	3665	2/0
15040G7E030M67	3x95/50	36,4	43,8	4895	3/0
15040G7E030M68	3x120/60	39,8	47,6	6010	4/0
15040G7E030M69	3x150/70	44,3	52,4	7310	250 MCM
15040G7E030M70	3x185/95	51	58,6	8970	350 MCM
15040G7E030M71	3x240/120	57,9	66,1	11620	450 MCM
15040G7E040M15	4x1,5/4	11,4	15,7	360	16
15040G7E040M25	4x2,5/4	12,3	16,6	435	14
15040G7E040M40	4x4/6	13,6	18,1	600	12
15040G7E040M60	4x6/6	15	19,5	735	10
15040G7E040M61	4x10/10	17,3	22,1	965	8
15040G7E040M62	4x16/16	20,2	25,2	1385	6
15040G7E040M63	4x25/16	24,8	30	1975	4
15040G7E040M64	4x35/16	27	32,4	2420	2
15040G7E040M65	4x50/25	31,1	37,3	3375	1
15040G7E040M66	4x70/35	35,1	42,1	4590	2/0
15040G7E040M67	4x95/50	40,4	48,2	6030	3/0
15040G7E040M68	4x120/60	44,6	52,7	7450	4/0
15040G7E050M15	5x1,5	12,4	16,7	430	16
15040G7E070M15	7x1,5	13,5	17,8	550	16
15040G7E120M15	12x1,5	17,7	22,5	815	16
15040G7E190M15	19x1,5	21	26	1110	16
15040G7E270M15	27x1,5	25,2	30,6	1470	16
15040G7E370M15	37x1,5	28,3	33,9	1850	16
15040G7E050M25	5x2,5	13,5	18	565	14
15040G7E070M25	7x2,5	14,7	19,2	665	14
15040G7E120M25	12x2,5	19,6	24,5	1005	14
15040G7E190M25	19x2,5	23	28,2	1370	14
15040G7E270M25	27x2,5	27,6	33,2	1825	14
15040G7E370M25	37x2,5	31,3	37,1	2330	14

Other dimensions and colors available on request.

GAALSHIP® BU

P17 or P17+MUD 0,6/1 kV.



ELETTROTEK KABEL® GAALSHIP® BU



Construction:

Conductor:	stranded tinned copper conductor Cl. 2, acc to IEC 60228
Insulation:	EPR, Halogen free compound + MICA glass tape acc.to IEC 60092-351, thickness acc. to IEC 60092-353
Cores color:	acc. to NEK on request HD 308 S2
Outer sheath:	black (RAL 9005), halogen-free mud resistant thermosetting type SHF MUD, acc. to NEK IIII ed. 2009. Thickness acc. to IEC 60092-353

Resistance:



Fire resistant acc. to:
IEC 60331-21



Flame and fire retardant acc. to:
IEC 60332-1-2,
IEC 60332-3-22



Halogen free acc. to:
IEC 60754-1



Smoke emission properties acc. to:
IEC 61034-2

Technical data:

Nominal voltage:	0,6/1 kV
Temperature range:	- 40°C up to +90°C
Installation temp.:	- 20 °C
Short circuit temperature:	+250°C
Min. bending radius:	6 x D

Features:

Sheathing materials acc. to: IEC 60092-359

Insulating materials acc. to: IEC 60092-351

Design guidelines acc. to:
IEC 60092-350-353 / ...-350 NEK 606 IIII ed 2009

Choice and installation of electric cables acc. to: IEC 60092-352
on request class 5

on request halogen free thermosetting type SHF2 outer sheath,
acc. to IEC 60092-359 and CSA 22.2 n.38-95
cold bend-impact test at low temperature (-40°C)

acc. to NEK 606 IIII ed. 2009,
Halogen free & MUD resistance cables,
for the marine, ship and offshore

We have possibility to provide the following Certifications on request:

Det Norske Veritas (DNV)

Lloyd's Register (LR)



Available on stock CABLE GLANDS:
see page 404 up to 416 of catalogue.

GAALSHIP® OFFSHORE CABLES

GAALSHIP® BU

P17 or P17+MUD 0,6/1 kV.



ELETTROTEK KABEL® GAALSHIP® BU



Part no.	No. of cores x cross section n x mm ²	Outer-Ø ca. mm ± 10%	Copper weight kg/km	Cable weight approx. kg/km	AWG no. *)
15060G7E010M61	1x10	8,8	96	180	8
15060G7E010M62	1x16	10,2	153,6	250	6
15060G7E010M63	1x25	12	240	370	4
15060G7E010M64	1x35	13,1	336	465	2
15060G7E010M65	1x50	14,7	480	610	1
15060G7E010M66	1x70	16,6	672	815	2/0
15060G7E010M67	1x95	19	912	1105	3/0
15060G7E010M68	1x120	20,6	1152	1355	4/0
15060G7E010M69	1x150	22,7	1440	1645	250 MCM
15060G7E010M70	1X185	25,2	1776	2080	350 MCM
15060G7E010M71	1x240	28,4	2304	2665	450 MCM
15060G7E010M72	1x300	31,1	2880	3345	550 MCM
15060G7E020M15	2x1,5	10,3	28,8	165	16
15060G7E020M25	2x2,5	11	48	200	14
15060G7E020M40	2x4	12,3	76,8	260	12
15060G7E020M60	2x6	13,4	115,2	320	10
15060G7E020M61	2x10	15,6	192	455	8
15060G7E020M62	2x16	18,2	307,2	645	6
15060G7E020M63	2x25	22	480	980	4
15060G7E020M64	2x35	24	672	1225	2
15060G7E020M65	2x50	27,4	960	1625	1
15060G7E030M15	3x1,5	10,9	43,2	190	16
15060G7E030M25	3x2,5	11,9	720	240	14
15060G7E030M40	3x4	13,1	115,2	305	12
15060G7E030M60	3x6	14,2	172,8	385	10
15060G7E030M61	3x10	16,5	288	560	8
15060G7E030M62	3x16	19,3	460,8	805	6
15060G7E030M63	3x25	23,5	720	1230	4
15060G7E030M64	3x35	25,6	1008	1555	2
15060G7E030M65	3x50	29,5	1440	2085	1
15060G7E030M66	3x70	33,2	2016	2885	2/0
15060G7E030M67	3x95	38,5	2736	3810	3/0
15060G7E030M68	3x120	42	3456	4695	4/0
15060G7E030M69	3x150	46,3	4320	5695	250 MCM
15060G7E030M70	3x185	51,8	5328	7225	350 MCM
15060G7E030M71	3x240	58	6912	9330	450 MCM
15060G7E040M15	4x1,5	12,1	57,6	235	16
15060G7E040M25	4x2,5	13	96	285	14
15060G7E040M40	4x4	14,5	153,6	375	12
15060G7E040M60	4x6	15,8	230,4	500	10
15060G7E040M61	4x10	18,4	384	705	8
15060G7E040M62	4x16	21,5	614,4	1015	6
15060G7E040M63	4x25	26,1	960	1560	4
15060G7E040M64	4x35	28,5	1344	1980	2
15060G7E040M65	4x50	32,8	1920	2655	1
15060G7E040M66	4x70	36,9	2688	3555	2/0
15060G7E040M67	4x95	42,8	3648	4860	3/0
15060G7E040M68	4x120	46,5	4608	5975	4/0
15060G7E050M15	5x1,5	13,2	72	275	16
15060G7E070M15	7x1,5	14,6	100,8	345	16
15060G7E120M15	12x1,5	19,3	172,8	540	16
15060G7E190M15	19x1,5	23	273,6	800	16
15060G7E270M15	27x1,5	27,8	388,8	1090	16
15060G7E370M15	37x1,5	31,5	532,8	1455	16
15060G7E050M25	5x2,5	14,5	120	350	14
15060G7E070M25	7x2,5	15,8	168	430	14
15060G7E120M25	12x2,5	21,1	288	690	14
15060G7E190M25	19x2,5	25	456	1010	14
15060G7E270M25	27x2,5	30,4	648	1405	14
15060G7E370M25	37x2,5	34,5	888	1875	14

Other dimensions and colors available on request.

GAALSHIP® BFOU

P5 or P5/PI2 0,6/1 kV



ELETTROTEK KABEL® GAALSHIP® BFOU



Construction:

Conductor:	stranded tinned copper conductor Cl. 2, acc to IEC 60228
Insulation:	EPR, Halogen free compound + MICA glass tape acc.to IEC 60092-351, thickness acc. to IEC 60092-353
Cores color:	acc. to NEK on request HD 308 S2
Inner sheath:	halogen-free compound acc. to IEC 60092-353
Armouring:	tinned copper wires braid acc. to IEC 60092-350, IEC 60092-352 used as earth conductor
Outer sheath:	black (RAL 9005), halogen-free mud resistant thermosetting type SHF MUD, acc. to NEK IIII ed. 2009. Thickness acc. to IEC 60092-353

Technical data:

Nominal voltage:	0,6/1 kV
Temperature range:	- 40°C up to +90°C
Installation temp.:	- 20 °C
Short circuit temperature:	+250°C
Min. bending radius:	6 x D

Resistance:



Fire resistant acc. to:
IEC 60331- 21



Flame and fire retardant acc. to:
IEC 60332-1-2,
IEC 60332-3-22



Halogen free acc. to:
IEC 60754-1



Smoke emission properties acc. to:
IEC 61034-2

Features:

Sheathing materials acc. to: IEC 60092-359

Insulating materials acc. to: IEC 60092-351

Design guidelines acc. to:
IEC 60092-350-353 / ...-350 NEK 606 IIII ed 2009

Choice and installation of electric cables acc. to: IEC 60092-352
on request class 5

on request halogen free thermosetting type SHF2 outer sheath,
acc. to IEC 60092-359 and CSA 22.2 n.38-95
cold bend-impact test at low temperature (-40°C)

acc. to NEK 606 IIII ed. 2009,
Halogen free & MUD resistance cables,
for the marine, ship and offshore

We have possibility to provide the following Certifications on request:

Det Norske Veritas (DNV)

Lloyd's Register (LR)



Available on stock CABLE GLANDS:
see page 404 up to 416 of catalogue.

GAALSHIP® OFFSHORE CABLES

GAALSHIP® BFOU

P5 or P5/PI2 0,6/1 kV



ELETTROTEK KABEL® GAALSHIP® BFOU

Part no.	No. of cores x cross section n x mm ²	Ø under armour ca. mm ± 10%	Outer-Ø ca. mm ± 10%	Cable weight approx. kg/km	AWG no. *)
15080G7E010M61	1x10	9	12,7	320	8
15080G7E010M62	1x16	10,2	13,9	400	6
15080G7E010M63	1x25	12	16,3	595	4
15080G7E010M64	1x35	12,9	17,2	700	2
15080G7E010M65	1x50	14,5	19	900	1
15080G7E010M66	1x70	16,1	20,6	1120	2/0
15080G7E010M67	1x95	18,4	23,1	1450	3/0
15080G7E010M68	1x120	20	25	1745	4/0
15080G7E010M69	1x150	21,8	27	2070	250 MCM
15080G7E010M70	1x185	24,2	29,4	2555	350 MCM
15080G7E010M71	1x240	27,2	32,6	3180	450 MCM
15080G7E010M72	1x300	29,7	35,3	3920	550 MCM
15080G7E020M15	2x1,5/4	10,5	14,2	320	16
15080G7E020M25	2x2,5/4	11,2	15,1	370	14
15080G7E020M40	2x4/6	12,3	16,6	480	12
15080G7E020M60	2x6/6	13,4	17,9	565	10
15080G7E020M61	2x10/10	15,4	19,9	715	8
15080G7E020M62	2x16/16	17,8	22,5	995	6
15080G7E020M63	2x25/16	21,4	26,4	1370	4
15080G7E020M64	2x35/16	24,4	28,4	1630	2
15080G7E020M65	2x50/25	26,4	32,4	2300	1
15080G7E030M15	3x1,5/4	11,1	14,8	355	16
15080G7E030M25	3x2,5/4	11,9	16,2	455	14
15080G7E030M40	3x4/6	13,1	17,4	540	12
15080G7E030M60	3x6/6	14,2	18,7	645	10
15080G7E030M61	3x10/10	16,4	21,1	840	8
15080G7E030M62	3x16/16	18,9	23,7	1170	6
15080G7E030M63	3x25/16	22,9	28,1	1650	4
15080G7E030M64	3x35/16	24,8	30,2	1990	2
15080G7E030M65	3x50/25	28,3	34,3	2760	1
15080G7E030M66	3x70/35	32,2	39	3685	2/0
15080G7E030M67	3x95/50	37,1	44,7	7965	3/0
15080G7E030M68	3x120/60	40,4	48,3	6045	4/0
15080G7E030M69	3x150/70	44,9	53,2	7365	250 MCM
15080G7E030M70	3x185/95	51,7	59,5	9035	350 MCM
15080G7E030M71	3x240/12	56,5	66,5	11600	450 MCM
15080G7E040M15	4x1,5/4	12,1	16,4	410	16
15080G7E040M25	4x2,5/6	13	17,3	515	14
15080G7E040M40	4x4/6	14,3	18,8	630	12
15080G7E040M60	4x6/6	15,6	20,1	760	10
15080G7E040M61	4x10/10	18	22,7	995	8
15080G7E040M62	4x16/16	20,9	25,9	1410	6
15080G7E040M63	4x25/16	25,3	30,7	2005	4
15080G7E040M64	4x35/16	27,5	33,1	2450	2
15080G7E040M65	4x50/25	31,8	38,2	3440	1
15080G7E040M66	4x70/35	35,7	42,7	4610	2/0
15080G7E040M67	4x95/50	41,6	49,4	6145	3/0
15080G7E040M68	4x120/60	45,4	53,6	7525	4/0
15080G7E050M15	5x1,5	13,2	17,7	520	16
15080G7E070M15	7x1,5	14,4	18,9	600	16
15080G7E120M15	12x1,5	18,9	23,9	890	16
15080G7E190M15	19x1,5	22,2	27,4	1195	16
15080G7E270M15	27x1,5	26,8	32,3	1585	16
15080G7E370M15	37x1,5	30,5	36,3	2025	16
15080G7E050M25	5x2,5	14,3	18,8	605	14
15080G7E070M25	7x2,5	15,6	20,1	710	14
15080G7E120M25	12x2,5	20,5	25,5	1055	14
15080G7E190M25	19x2,5	24,2	29,6	1455	14
15080G7E270M25	27x2,5	29,6	35,4	1980	14
15080G7E370M25	37x2,5	33,2	39,8	2620	14

Other dimensions and colors available on request.

GAALSHIP® UX
P15 0,6/1 kV.



ELETTROTEK KABEL® GAALSHIP® UX

Construction:

- Conductor:** stranded tinned copper conductor Cl. 2, acc to IEC 60228
- Insulation:** Halogen free thermosetting type SHF2, acc. to IEC 60092-359.
Thickness acc. to IEC 60092-353
unsheathed, unarmoured
- Cores color:** black (RAL 9005) acc.to NEK 606 and HD 308 S2
or green-yellow for use as protective earth wire

Technical data:

- Nominal voltage:** 0,6/1 kV
- Temperature range:** - 40°C up to +90°C
- Installation temp.:** - 20 °C
- Short circuit temperature:** +250°C
- Min. bending radius:** D < 25 mm = 4 x D
D > 25 mm = 6 x D

Resistance:



Flame and fire retardant acc. to:
IEC 60332-1-2,
IEC 60332-3-22



Halogen free acc. to:
IEC 60754-1



Smoke emission properties acc. to:
IEC 61034-2

Features:

- Sheathing materials acc. to: IEC 60092-359
- Insulating materials acc. to: IEC 60092-351
- Design guidelines acc. to:
IEC 60092-350-353 / ...-350 NEK 606 III ed. 2009
- Choice and installation of electric cables acc. to: IEC 60092-352
on request class 5

on request halogen free thermosetting type SHF2 outer sheath,
acc. to IEC 60092-359 and CSA 22.2 n.38-95
cold bend-impact test at low temperature (-40°C)

acc. to NEK 606 III ed. 2009,
Halogen free & MUD resistance cables,
for the marine, ship and offshore

We have possibility to provide the following Certifications on request:

- Det Norske Veritas (DNV)
- Lloyd's Register (LR)



Available on stock CABLE GLANDS:
see page 404 up to 416 of catalogue.

Part no.	No. of cores x cross section n x mm ²	Outer-Ø ca.mm ± 10%	Copper weight kg/km	Cable weight approx. kg/km	AWG no.)*
15090G01010M61	1x10	6,6	96	135	8
15090G01010M62	1x16	7,7	153,6	195	6
15090G01010M63	1x25	9,5	240	300	4
15090G01010M64	1x35	10,4	336	390	2
15090G01010M65	1x50	12,1	480	520	1
15090G01010M66	1x70	13,6	672	710	2/0
15090G01010M67	1x95	15,5	912	960	3/0
15090G01010M68	1x120	17,5	1152	1215	4/0
15090G01010M69	1x150	19,4	1440	1480	250 MCM
15090G01010M70	1x185	21,7	1776	1885	350 MCM
15090G01010M71	1x240	24,7	2304	2430	450 MCM
15090G01010M72	1x300	27,2	2880	3070	550 MCM

Other dimensions and colors available on request.

GAALSHIP® F-RFOU 0,6/1 kV.



ELETTROTEK KABEL® GAALSHIP® F-RFOU



Construction:

- Conductor:** flexible tinned copper conductor Cl. 5, acc to IEC 60228
- Insulation:** EPR, Halogen free compound acc. to IEC 60092-351, thickness acc. to IEC 60092-353
- Cores color:** acc. to NEK on request HD 308 S2
- Inner sheath:** halogen-free compound acc. to IEC 60092-353
- Armouring:** Cu/PETP tape and copper braid made of tinned copper wires acc. to IEC 60092-353, overall tinned copper braid and foil shield (PET+copper), 100% coverage containing VFD EMI emission.
- Outer sheath:** black (RAL 9005), halogen-free mud resistant thermosetting type SHF MUD, acc. to NEK III ed. 2009. Thickness acc. to IEC 60092-353

Resistance:



Flame and fire retardant acc. to:
IEC 60332-1-2,
IEC 60332-3-22



Halogen free acc. to:
IEC 60754-1



Smoke emission properties acc. to:
IEC 61034-2

Technical data:

- Nominal voltage:** 0,6/1 kV
- Temperature range:** - 40°C up to +90°C
- Installation temp.:** - 20 °C
- Short circuit temperature:** +250°C
- Min. bending radius:** 6 x D

Features:

- Sheathing materials acc. to: IEC 60092-359
- Insulating materials acc. to: IEC 60092-351
- Design guidelines acc. to:
IEC 60092-350-353 / ...-350 NEK 606 III ed. 2009
- Choice and installation of electric cables acc. to: IEC 60092-352 on request class 5
- on request halogen free thermosetting type SHF2 outer sheath, acc. to IEC 60092-359 and CSA 22.2 n.38-95 cold bend-impact test at low temperature (-40°C)
- acc. to NEK 606 III ed. 2009,
Halogen free & MUD resistance cables,
for the marine, ship and offshore

We have possibility to provide the following Certifications on request:

- Det Norske Veritas (DNV)
Lloyd's Register (LR)



Available on stock CABLE GLANDS:
see page 404 up to 416 of catalogue.

Part no.	No. of cores x cross section n x mm ²	Ø under armour ca. mm ± 10%	Outer-Ø ca. mm ± 10%	Cable weight approx. kg/km	AWG no. *)
15110G7E030M65	3x50/25	28,5	34,7	2710	1
15110G7E030M66	3x70/35	32,6	39,6	3660	2/0
15110G7E030M67	3x95/50	36,3	43,9	4660	3/0
15110G7E030M68	3x120/60	41	49,1	5910	4/0
15110G7E030M69	3x150/70	46,1	54,5	7310	250 MCM

Other dimensions and colors available on request.

GAALSHIP® RFOU

P2... P2.../... P21 from 3,6/6 kV to 12/20 kV



ELETTROTEK KABEL® GAALSHIP® RFOU

Construction:

Conductor:	stranded tinned copper conductor Cl. 2, acc to IEC 60228
Wrapping:	semiconducting tape and/or semiconducting layer.
Insulation:	EPR, Halogen free compound acc. to IEC 60092-351, thickness acc. to IEC 60092-353
Screen:	semiconducting layer and tinned copper wire braid.
Cores color:	1x: natural color 3x: white-black-red
Inner sheath:	halogen-free compound acc. to IEC 60092-354
Armouring:	tinned copper wires braid acc. to IEC 60092-350, IEC 60092-352 used as earth conductor.
Outer sheath:	red (RAL 3000), halogen-free mud resistant thermosetting type SHF MUD, acc. to NEK IIII ed. 2009. Thickness acc. To IEC 60092-354

Resistance:



Flame and fire retardant acc. to:
IEC 60332-1-2,
IEC 60332-3-22



Halogen free acc. to:
IEC 60754-1/2



Smoke emission properties acc. to:
IEC 61034-1/2

Technical data:

Nominal voltage:	from 3,6/6 kV to 12/20 kV
Temperature range:	- 40°C up to +90°C
<i>Installation temp.:</i>	- 20 °C
Short circuit temperature:	+250°C
Min. bending radius:	9 x D

Features:

Sheathing materials acc. to: IEC 60092-359
Insulating materials acc. to: IEC 60092-351
Design guidelines acc. to:
IEC 60092-350-353 / ...-350 NEK 606 IIII ed. 2009
Choice and installation of electric cables acc. to: IEC 60092-352
on request class 5

on request halogen free thermosetting type SHF2 outer sheath, acc. to IEC 60092-359 and CSA 22.2 n.38-95 cold bend-impact test at low temperature (-40°C)

acc. to NEK 606 IIII ed. 2009,
Halogen free & MUD resistance cables,
for the marine, ship and offshore

We have possibility to provide the following Certifications on request:

Det Norske Veritas (DNV)

Lloyd's Register (LR)



Available on stock CABLE GLANDS:
see page 404 up to 416 of catalogue.

GAALSHIP® RFOU

P2... P2.../... P2I from 3,6/6 kV to 12/20 kV



3,6/6 kV P2 or P2/P9

Part no.	No. of cores x cross section n x mm ²	Ø under armour ca. mm ± 10%	Outer-Ø ca. mm ± 10%	Cable weight approx. kg/km	AWG no. *)
16020MRL010M63	1x25	19,2	24	1030	4
16020MRL010M64	1x35	20,1	25,1	1165	2
16020MRL010M65	1x50	21,3	26,3	1330	1
16020MRL010M66	1x70	23	28,2	1605	2/0
16020MRL010M67	1x95	24,8	30	1915	3/0
16020MRL010M68	1x120	26,4	31,8	2245	4/0
16020MRL010M69	1x150	27,9	33,5	2565	250 MCM
16020MRL010M70	1x185	29,8	35,4	3025	350 MCM
16020MRL010M71	1x240	33	38,8	3735	450 MCM
16020MRL010M72	1x300	35,9	42,3	4635	550 MCM
16020MRE030M63	3x25/16	38,8	45,4	3400	4
16020MRE030M64	3x35/16	40,8	47,6	3830	2
16020MRE030M65	3x50/25	43,8	50,9	4505	1
16020MRE030M66	3x70/35	47,3	54,8	5595	2/0
16020MRE030M67	3x95/50	51,2	58,9	6775	3/0
16020MRE030M68	3x120/60	55	63,5	8175	4/0
16020MRE030M69	3x150/70	58,3	67,4	9505	250 MCM

6/10 kV P3 or P3/P10

Part no.	No. of cores x cross section n x mm ²	Ø under armour ca. mm ± 10%	Outer-Ø ca. mm ± 10%	Cable weight approx. kg/km	AWG no. *)
16020QRL010M63	1x25	21	26	1150	4
16020QRL010M64	1x35	21,9	26,9	1275	2
16020QRL010M65	1x50	23,1	28,3	1470	1
16020QRL010M66	1x70	24,8	30	1720	2/0
16020QRL010M67	1x95	26,6	32	2070	3/0
16020QRL010M68	1x120	28,2	33,8	2390	4/0
16020QRL010M69	1x150	29,7	35,3	2710	250 MCM
16020QRL010M70	1x185	32	37,8	3235	350 MCM
16020QRL010M71	1x240	34,6	41	4000	450 MCM
16020QRL010M72	1x300	37,1	43,7	4770	550 MCM
16020QRE030M63	3x25/16	43,1	50,1	3915	4
16020QRE030M64	3x35/16	45,1	52,2	4370	2
16020QRE030M65	3x50/25	47,6	55,1	5195	1
16020QRE030M66	3x70/35	51,2	58,9	6135	2/0
16020QRE030M67	3x95/50	55,5	63,5	7510	3/0
16020QRE030M68	3x120/60	58,9	67,6	8785	4/0
16020QRE030M69	3x150/70	62,2	71,7	10245	250 MCM

GAALSHIP® OFFSHORE CABLES

GAALSHIP® RFOU

P2... P2.../... P21 from 3,6/6 kV to 12/20 kV



8,7/15 kV P4 or P4/P11

Part no.	No. of cores x cross section n x mm ²	Ø under armour ca. mm ± 10%	Outer-Ø ca. mm ± 10%	Cable weight approx. kg/km	AWG no. *)
16020SRL010M63	1x25	23,2	28,4	1315	4
16020SRL010M64	1x35	24,1	29,3	1440	2
16020SRL010M65	1x50	25,3	30,7	1630	1
16020SRL010M66	1x70	27	32,4	1910	2/0
16020SRL010M67	1x95	28,8	34,4	2260	3/0
16020SRL010M68	1x120	30,8	36,6	2635	4/0
16020SRL010M69	1x150	32,3	38,1	2950	250 MCM
16020SRL010M70	1x185	34,2	40,6	3555	350 MCM
16020SRL010M71	1x240	36,8	43,4	4230	450 MCM
16020SRL010M72	1x300	39,5	46,3	5080	550 MCM
16020SRE030M63	3x25/16	47,9	55,3	4735	4
16020SRE030M64	3x35/16	49,8	57,5	5225	2
16020SRE030M65	3x50/25	52,8	60,6	5970	1
16020SRE030M66	3x70/35	56,3	64,4	7045	2/0
16020SRE030M67	3x95/50	60,2	68,7	8380	3/0
16020SRE030M68	3x120/60	63,7	72,7	9755	4/0
16020SRE030M69	3x150/70	66,9	76,8	11150	250 MCM

12/20 kV P19 or P19/P21

Part no.	No. of cores x cross section n x mm ²	Ø under armour ca. mm ± 10%	Outer-Ø ca. mm ± 10%	Cable weight approx. kg/km	AWG no. *)
16020URL010M63	1x25	26,2	31,5	1540	4
16020URL010M64	1x35	26,1	31,6	1605	2
16020URL010M65	1x50	27,3	32,9	1805	1
16020URL010M66	1x70	29	34,6	2080	2/0
16020URL010M67	1x95	31,2	37	2480	3/0
16020URL010M68	1x120	32,8	38,8	2820	4/0
16020URL010M69	1x150	34,3	40,7	3255	250 MCM
16020URL010M70	1x185	36,3	42,9	3775	350 MCM
16020URL010M71	1x240	39	45,8	4520	450 MCM
16020URL010M72	1x300	41,5	48,5	5325	550 MCM
16020URE030M63	3x25/16	54,3	62,2	5715	4
16020URE030M64	3x35/16	54,5	62,6	6000	2
16020URE030M65	3x50/25	57,1	65,4	6750	1
16020URE030M66	3x70/35	60,6	69,1	7800	2/0
16020URE030M67	3x95/50	64,5	73	9160	3/0
16020URE030M68	3x120/60	68	77,4	10590	4/0
16020URE030M69	3x150/70	71,6	81,9	12155	250 MCM

Other dimensions and colors available on request.

GAALSHIP® RU(i)

SII or SII+MUD 150/250V



Construction:

Conductor:	stranded tinned copper conductor Cl. 2, acc to IEC 60228
Insulation:	EPR, Halogen free compound + MICA glass tape acc.to IEC 60092-351, thickness acc. to IEC 60092-376
Cores color:	pair: black- light blue triple: black- light blue - brown
Stranding:	cores lay-up in pairs, triples, laying-up of pairs, triples
Screen:	individual screen, copper/polyester tape with tinned copper stranded drain wire and synthetic tape
Outer sheath:	grey (RAL 7001) halogen-free mud resistant thermosetting type SHF MUD, acc. to NEK IIII edit. 2009. thickness acc. to IEC 60092-376

Technical data:

Nominal voltage:	150/250 V
Temperature range:	- 40°C up to +90°C
<i>Installation temp.:</i>	- 20 °C
Short circuit temperature:	+250°C
Min. bending radius:	8 x D

Resistance:



Flame and fire retardant acc. to:
IEC 60332-1-2,
IEC 60332-3-22



Halogen free acc. to:
IEC 60754-1



Smoke emission properties acc. to:
IEC 61034-2

Features:

Sheathing materials acc. to: IEC 60092-359
Insulating materials acc. to: IEC 60092-351
Design guidelines acc. to:
IEC 60092-350-376 / ...-350 NEK 606 IIII ed. 2009
Choice and installation of electric cables acc. to: IEC 60092-352 on request class 5

on request halogen free thermosetting type SHF2 outer sheath, acc. to IEC 60092-359 and CSA 22.2 n.38-95 cold bend-impact test at low temperature (-40°C)

acc. to NEK 606 IIII ed. 2009,
Halogen free & MUD resistance cables,
for the marine, ship and offshore

We have possibility to provide the following Certifications on request:

Det Norske Veritas (DNV)
Lloyd's Register (LR)



Available on stock CABLE GLANDS:
see page 404 up to 416 of catalogue.

GAALSHIP® OFFSHORE CABLES

GAALSHIP® RU(i)
SII or SII+MUD 150/250V



Part no.	No. of pairs/triples x cross section n x mm ²	Outer-Ø ca. mm ± 10%	Copper weight kg/km	Cable weight approx. kg/km	AWG no. *)
14020C5X012M07	1x2x0,75	7,6	18	105	19
14020C5X022M07	2x2x0,75	9,7	36	190	19
14020C5X042M07	4x2x0,75	12,1	54	265	19
14020C5X072M07	7x2x0,75	14,4	72	390	19
14020C5X082M07	8x2x0,75	15,6	144	435	19
14020C5X122M07	12x2x0,75	19	216	620	19
14020C5X162M07	16x2x0,75	21	288	795	19
14020C5X192M07	19x2x0,75	22,4	342	905	19
14020C5X242M07	24x2x0,75	25,6	432	1145	19
14020C5X322M07	32x2x0,75	28,4	576	1450	19
14020C5X012M10	1x2x1	8,1	23	120	18
14020C5X022M10	2x2x1	10,4	45	225	18
14020C5X042M10	4x2x1	12,9	90	320	18
14020C5X072M10	7x2x1	15,5	158	485	18
14020C5X082M10	8x2x1	17	180	550	18
14020C5X122M10	12x2x1	20,5	270	770	18
14020C5X162M10	16x2x1	22,9	360	1005	18
14020C5X192M10	19x2x1	24,1	428	1145	18
14020C5X242M10	24x2x1	27,8	540	1460	18
14020C5X322M10	32x2x1	30,8	720	1860	18
14020C5X012M15	1x2x1,5	9,1	32	150	16
14020C5X022M15	2x2x1,5	11,7	63	290	16
14020C5X042M15	4x2x1,5	14,9	126	420	16
14020C5X072M15	7x2x1,5	18	221	645	16
14020C5X082M15	8x2x1,5	19,7	252	730	16
14020C5X122M15	12x2x1,5	23,8	378	1025	16
14020C5X162M15	16x2x1,5	26,6	504	1340	16
14020C5X192M15	19x2x1,5	28,3	599	1535	16
14020C5X242M15	24x2x1,5	32,6	756	1955	16
14020C5X322M15	32x2x1,5	36,1	1022	2485	16
14020C5X012M25	1x2x2,5	9,8	50	185	14
14020C5X013M07	1x3x0,75	8	25	120	19
14020C5X033M07	3x3x0,75	12,7	75	275	19
14020C5X043M07	4x3x0,75	13,8	99	335	19
14020C5X073M07	7x3x0,75	16,7	174	510	19
14020C5X123M07	12x3x0,75	22,2	297	825	19
14020C5X163M07	16x3x0,75	24,7	396	1055	19
14020C5X193M07	19x3x0,75	26,2	471	1215	19
14020C5X243M07	24x3x0,75	30,5	594	1555	19
14020C5X013M10	1x3x1	8,5	32	135	18
14020C5X033M10	3x3x1	13,4	95	330	18
14020C5X043M10	4x3x1	14,8	126	405	18
14020C5X073M10	7x3x1	17,9	221	625	18
14020C5X123M10	12x3x1	23,7	378	1000	18
14020C5X163M10	16x3x1	26,5	504	1305	18
14020C5X193M10	19x3x1	28	599	1485	18
14020C5X243M10	24x3x1	32,6	756	1910	18
14020C5X013M15	1x3x1,5	9,5	45	170	16
14020C5X033M15	3x3x1,5	15,5	135	435	16
14020C5X043M15	4x3x1,5	17	180	535	16
14020C5X073M15	7x3x1,5	20,9	315	840	16
14020C5X123M15	12x3x1,5	27,6	540	1350	16
14020C5X163M15	16x3x1,5	31,1	720	1780	16
14020C5X193M15	19x3x1,5	32,8	855	2030	16
14020C5X243M15	24x3x1,5	38,4	1080	2620	16
14020C5X013M25	1x3x2,5	10,4	72	215	14

Other dimensions and colors available on request.

GAALSHIP® RFOU(i)

S1 or S1/S5 150/250V



Construction:

Conductor:	stranded tinned copper conductor Cl. 2, acc to IEC 60228
Insulation:	EPR, Halogen free compound acc.to IEC 60092-351, thickness acc. to IEC 60092-376
Cores color:	pair: black- light blue triple: black- light blue - brown
Stranding:	cores lay-up in pairs, triples, laying-up of pairs, triples
Screen:	individual screen, copper/polyester tape with tinned copper stranded drain wire and synthetic tape
Inner sheath:	halogen-free compound acc. to IEC 60092-353, indicative thickness acc. to IEC 60092-376
Armouring:	tinned copper wires braid acc. to IEC 60092-350
Outer sheath:	grey (RAL 7001) halogen-free mud resistant thermosetting type SHF MUD, acc. to NEK IIII edit. 2009, thickness acc. to IEC 60092-376

Technical data:

Nominal voltage:	150/250 V
Temperature range:	- 40°C up to +90°C
<i>Installation temp.:</i>	- 20 °C
Short circuit temperature:	+250°C
Min. bending radius:	8 x D

Resistance:



Flame and fire retardant acc. to:
IEC 60332-1-2,
IEC 60332-3-22



Halogen free acc. to:
IEC 60754-1



Smoke emission properties acc. to:
IEC 61034-2

Features:

Sheathing materials acc. to: IEC 60092-359
Insulating materials acc. to: IEC 60092-351
Design guidelines acc. to:
IEC 60092-350-376 / ...-350 NEK 606 IIII ed. 2009
Choice and installation of electric cables acc. to: IEC 60092-352 on request class 5

on request halogen free thermosetting type SHF2 outer sheath, acc. to IEC 60092-359 and CSA 22.2 n.38-95 cold bend-impact test at low temperature (-40°C)

acc. to NEK 606 IIII ed. 2009,
Halogen free & MUD resistance cables,
for the marine, ship and offshore

We have possibility to provide the following Certifications on request:

Det Norske Veritas (DNV)
Lloyd's Register (LR)



Available on stock CABLE GLANDS:
see page 404 up to 416 of catalogue.

GAALSHIP® OFFSHORE CABLES

GAALSHIP® RFOU(i)

SI or SI/S5 150/250V



Part no.	No. of pairs/triples x cross section n x mm ²	Ø under armour ca. mm ± 10%	Outer-Ø ca. mm ± 10%	Cable weight approx. kg/km	AWG no. *)
14040C5X012M07	1x2x0,75	7,7	10,9	105	19
14040C5X022M07	2x2x0,75	9,8	13,2	190	19
14040C5X042M07	4x2x0,75	12,2	16,2	265	19
14040C5X072M07	7x2x0,75	14,8	19	390	19
14040C5X082M07	8x2x0,75	16	20,4	435	19
14040C5X122M07	12x2x0,75	19,4	24,1	620	19
14040C5X162M07	16x2x0,75	21,4	26,3	795	19
14040C5X192M07	19x2x0,75	22,6	27,5	905	19
14040C5X242M07	24x2x0,75	25,8	31,1	1145	19
14040C5X322M07	32x2x0,75	28,4	33,8	1450	19
14040C5X012M10	1x2x1	8,2	11,4	120	18
14040C5X022M10	2x2x1	10,5	14,5	225	18
14040C5X042M10	4x2x1	13,4	17,4	320	18
14040C5X072M10	7x2x1	15,9	20,1	485	18
14040C5X082M10	8x2x1	17,2	21,6	550	18
14040C5X122M10	12x2x1	20,9	25,6	770	18
14040C5X162M10	16x2x1	23,1	28	1005	18
14040C5X192M10	19x2x1	24,5	29,6	1145	18
14040C5X242M10	24x2x1	27,8	33,1	1460	18
14040C5X322M10	32x2x1	30,9	36,5	1860	18
14040C5X012M15	1x2x1,5	9,2	12,4	150	16
14040C5X022M15	2x2x1,5	11,8	15,8	290	16
14040C5X042M15	4x2x1,5	15,3	19,5	420	16
14040C5X072M15	7x2x1,5	18,6	23	645	16
14040C5X082M15	8x2x1,5	20,1	24,8	730	16
14040C5X122M15	12x2x1,5	24,2	29,3	1025	16
14040C5X162M15	16x2x1,5	26,8	32,1	1340	16
14040C5X192M15	19x2x1,5	28,3	33,6	1535	16
14040C5X242M15	24x2x1,5	32,4	38,7	1955	16
14040C5X322M15	32x2x1,5	36,3	42,8	2485	16
14040C5X012M25	1x2x2,5	9,9	13,3	330	14
14040C5X013M07	1x3x0,75	8,1	11,3	235	19
14040C5X033M07	3x3x0,75	13,2	17,2	530	19
14040C5X043M07	4x3x0,75	14,3	18,5	620	19
14040C5X073M07	7x3x0,75	17,1	21,5	845	19
14040C5X123M07	12x3x0,75	22,4	27,3	1285	19
14040C5X163M07	16x3x0,75	25	30,1	1595	19
14040C5X193M07	19x3x0,75	26,4	31,5	1785	19
14040C5X243M07	24x3x0,75	30,5	36	2230	19
14040C5X013M10	1x3x1	8,6	11,8	260	18
14040C5X033M10	3x3x1	13,9	17,9	600	18
14040C5X043M10	4x3x1	15,2	19,4	710	18
14040C5X073M10	7x3x1	18,5	22,9	1000	18
14040C5X123M10	12x3x1	24,1	28,9	1510	18
14040C5X163M10	16x3x1	26,7	31,8	1880	18
14040C5X193M10	19x3x1	28,2	33,4	2050	18
14040C5X243M10	24x3x1	32,6	38,7	2695	18
14040C5X013M15	1x3x1,5	9,6	13	310	16
14040C5X033M15	3x3x1,5	15,9	20,1	750	16
14040C5X043M15	4x3x1,5	17,4	21,8	880	16
14040C5X073M15	7x3x1,5	21,3	26	1275	16
14040C5X123M15	12x3x1,5	27,8	33,1	1960	16
14040C5X163M15	16x3x1,5	31,1	36,6	2460	16
14040C5X193M15	19x3x1,5	32,8	38,9	2820	16
14040C5X243M15	24x3x1,5	38,4	44,9	3640	16
14040C5X013M25	1x3x2,5	10,5	13,9	365	14

Other dimensions and colors available on request.

GAALSHIP® RU(c) S12 or S12+MUD 150/250V



Construction:

Conductor:	stranded tinned copper conductor Cl. 2, acc to IEC 60228
Insulation:	EPR, Halogen free compound acc.to IEC 60092-351, thickness acc. to IEC 60092-376
Cores color:	pair: black- light blue triple: black- light blue - brown
Stranding:	cores lay-up in pairs, triples, laying-up of pairs, triples
Screen:	overall screen, copper/polyester tape with tinned copper stranded drain wire and synthetic tape
Outer sheath:	grey (RAL 7001) halogen-free mud resistant thermosetting type SHF MUD, acc. to NEK IIII edit. 2009. thickness acc. to IEC 60092-376

Technical data:

Nominal voltage:	150/250 V
Temperature range:	- 40°C up to +90°C
<i>Installation temp.:</i>	- 20 °C
Short circuit temperature:	+250°C
Min. bending radius:	8 x D

Resistance:



Flame and fire retardant acc. to:
IEC 60332-1-2,
IEC 60332-3-22



Halogen free acc. to:
IEC 60754-1



Smoke emission properties acc. to:
IEC 61034-2

Features:

Sheathing materials acc. to: IEC 60092-359
Insulating materials acc. to: IEC 60092-351
Design guidelines acc. to:
IEC 60092-350-376 / ...-350 NEK 606 IIII ed. 2009
Choice and installation of electric cables acc. to: IEC 60092-352
on request class 5
on request halogen free thermosetting type SHF2 outer sheath,
acc. to IEC 60092-359 and CSA 22.2 n.38-95
cold bend-impact test at low temperature (-40°C)

acc. to NEK 606 IIII ed. 2009,
Halogen free & MUD resistance cables,
for the marine, ship and offshore

We have possibility to provide the following Certifications on request:

Det Norske Veritas (DNV)
Lloyd's Register (LR)



Available on stock CABLE GLANDS:
see page 404 up to 416 of catalogue.

GAALSHIP® OFFSHORE CABLES

GAALSHIP® RU(c)
SI2 or SI2+MUD I50/250V



ELETTROTEK KABEL® GAALSHIP® RU(c)

Part no.	No. of pairs/triples x cross section n x mm ²	Outer-Ø ca. mm ± 10%	Copper weight kg/km	Cable weight approx. kg/km	AWG no. *)
14060C5X022M07	2x2x0,75	9,4	32	170	19
14060C5X042M07	4x2x0,75	11,5	59	225	19
14060C5X072M07	7x2x0,75	13,6	99	310	19
14060C5X082M07	8x2x0,75	14,7	113	350	19
14060C5X122M07	12x2x0,75	17,6	167	475	19
14060C5X162M07	16x2x0,75	19,7	221	605	19
14060C5X192M07	19x2x0,75	20,7	261	675	19
14060C5X242M07	24x2x0,75	24,1	329	860	19
14060C5X322M07	32x2x0,75	26,7	437	1075	19
14060C5X022M10	2x2x1	9,9	41	200	18
14060C5X042M10	4x2x1	12,3	77	265	18
14060C5X072M10	7x2x1	14,7	131	380	18
14060C5X082M10	8x2x1	15,7	149	420	18
14060C5X122M10	12x2x1	18,9	221	575	18
14060C5X162M10	16x2x1	21,1	293	740	18
14060C5X192M10	19x2x1	22,5	347	840	18
14060C5X242M10	24x2x1	25,9	437	1060	18
14060C5X322M10	32x2x1	28,7	581	1325	18
14060C5X022M15	2x2x1,5	11,3	59	260	16
14060C5X042M15	4x2x1,5	14,1	113	355	16
14060C5X072M15	7x2x1,5	17,2	194	525	16
14060C5X082M15	8x2x1,5	18,4	221	585	16
14060C5X122M15	12x2x1,5	22,4	329	820	16
14060C5X162M15	16x2x1,5	25	437	1055	16
14060C5X192M15	19x2x1,5	26,4	518	1185	16
14060C5X242M15	24x2x1,5	30,7	653	1515	16
14060C5X322M15	32x2x1,5	33,9	869	1900	16
14060C5X033M07	3x3x0,75	12,1	66	245	19
14060C5X043M07	4x3x0,75	13,1	86	290	19
14060C5X073M07	7x3x0,75	15,7	147	420	19
14060C5X123M07	12x3x0,75	20,6	248	655	19
14060C5X163M07	16x3x0,75	23,1	329	845	19
14060C5X193M07	19x3x0,75	24,3	390	950	19
14060C5X243M07	24x3x0,75	28,2	491	1220	19
14060C5X033M10	3x3x1	12,9	86	290	18
14060C5X043M10	4x3x1	14	113	345	18
14060C5X072M10	7x3x1	16,9	194	510	18
14060C5X123M10	12x3x1	22,1	329	805	18
14060C5X163M10	16x3x1	24,8	437	1035	18
14060C5X193M10	19x3x1	26,3	518	1185	18
14060C5X243M10	24x3x1	30,4	653	1500	18
14060C5X033M15	3x3x1,5	14,9	126	390	16
14060C5X043M15	4x3x1,5	16,3	167	475	16
14060C5X073M15	7x3x1,5	19,8	288	715	16
14060C5X123M15	12x3x1,5	26,2	491	1150	16
14060C5X163M15	16x3x1,5	29,4	653	1485	16
14060C5X193M15	19x3x1,5	30,9	774	1685	16
14060C5X243M15	24x3x1,5	36,2	977	2170	16

Other dimensions and colors available on request.

GAALSHIP® RFOU(c)

S2 or S2/S6 150/250 V



ELETTROTEK KABEL® GAALSHIP® RFOU (c)

Construction:

Conductor:	stranded tinned copper conductor Cl. 2, acc to IEC 60228
Insulation:	EPR, Halogen free compound acc.to IEC 60092-351, thickness acc. to IEC 60092-376
Cores color:	pair: black- light blue triple: black- light blue - brown
Stranding:	cores lay-up in pairs, triples, laying-up of pairs, triples
Screen:	overall screen, copper/polyester tape with tinned copper stranded drain wire and synthetic tape
Inner sheath:	halogen-free compound, Indicative thickness acc. to IEC 60092-376
Armouring:	tinned copper wires braid acc. to IEC 60092-350
Outer sheath:	grey (RAL 7001) halogen-free mud resistant thermosetting type SHF MUD, acc. to NEK IIII edit. 2009, thickness acc. to IEC 60092-376

Resistance:



Flame and fire retardant acc. to:
IEC 60332-1-2,
IEC 60332-3-22



Halogen free acc. to:
IEC 60754-1



Smoke emission properties acc. to:
IEC 61034-2

Technical data:

Nominal voltage:	150/250 V
Temperature range:	- 40°C up to +90°C
<i>Installation temp.:</i>	- 20 °C
Short circuit temperature:	+250°C
Min. bending radius:	8 x D

Features:

Sheathing materials acc. to: IEC 60092-359
Insulating materials acc. to: IEC 60092-351
Design guidelines acc. to:
IEC 60092-350-376 / ...-350 NEK 606 IIII ed. 2009
Choice and installation of electric cables acc. to: IEC 60092-352 on request class 5

on request halogen free thermosetting type SHF2 outer sheath, acc. to IEC 60092-359 and CSA 22.2 n.38-95 cold bend-impact test at low temperature (-40°C)

acc. to NEK 606 IIII ed. 2009,
Halogen free & MUD resistance cables,
for the marine, ship and offshore

We have possibility to provide the following Certifications on request:

Det Norske Veritas (DNV)
Lloyd's Register (LR)



Available on stock CABLE GLANDS:
see page 404 up to 416 of catalogue.

GAALSHIP® OFFSHORE CABLES

GAALSHIP® RFOU(c)

S2 or S2/S6 150/250V

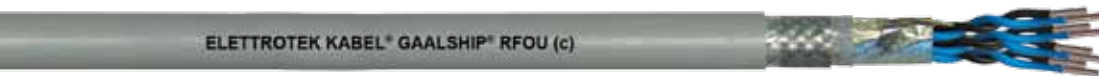

Part no.	No. of pairs/triples x cross section n x mm ²	Ø under armour ca. mm ± 10%	Outer-Ø ca. mm ± 10%	Cable weight approx. kg/km	AWG no. *)
14080C5X022M07	2x2x0,75	9,5	12,9	305	19
14080C5X042M07	4x2x0,75	11,6	15,6	400	19
14080C5X072M07	7x2x0,75	14,1	18,3	595	19
14080C5X082M07	8x2x0,75	15,1	19,3	655	19
14080C5X122M07	12x2x0,75	17,8	22,2	820	19
14080C5X162M07	16x2x0,75	20,1	24,8	1020	19
14080C5X192M07	19x2x0,75	21,1	26	1125	19
14080C5X242M07	24x2x0,75	24,3	29,4	1380	19
14080C5X322M07	32x2x0,75	26,7	31,9	1655	19
14080C5X022M10	2x2x1	10	13,4	345	18
14080C5X042M10	4x2x1	12,4	16,4	450	18
14080C5X072M10	7x2x1	15,1	19,3	685	18
14080C5X082M10	8x2x1	16,2	20,6	750	18
14080C5X122M10	12x2x1	19,5	24,2	990	18
14080C5X162M10	16x2x1	21,5	26,2	1185	18
14080C5X192M10	19x2x1	22,7	27,6	1305	18
14080C5X242M10	24x2x1	26,1	31,2	1630	18
14080C5X322M10	32x2x1	28,7	34,2	1950	18
14080C5X022M15	2x2x1,5	11,4	15,4	430	16
14080C5X042M15	4x2x1,5	14,6	18,8	645	16
14080C5X072M15	7x2x1,5	17,4	21,8	865	16
14080C5X082M15	8x2x1,5	19	23,7	985	16
14080C5X122M15	12x2x1,5	22,6	27,5	1280	16
14080C5X162M15	16x2x1,5	25,2	30,3	1585	16
14080C5X192M15	19x2x1,5	26,6	31,8	1775	16
14080C5X242M15	24x2x1,5	30,7	36,4	2210	16
14080C5X322M15	32x2x1,5	33,7	40	2755	16
14080C5X033M07	3x3x0,75	12,2	16,2	425	19
14080C5X043M07	4x3x0,75	13,6	17,6	550	19
14080C5X073M07	7x3x0,75	16,1	20,3	740	19
14080C5X123M07	12x3x0,75	21	25,7	1090	19
14080C5X163M07	16x3x0,75	23,3	28,2	1320	19
14080C5X193M07	19x3x0,75	24,7	29,8	1485	19
14080C5X243M07	24x3x0,75	28,2	33,7	1840	19
14080C5X033M10	3x3x1	13,4	17,4	550	18
14080C5X043M10	4x3x1	14,5	18,7	635	18
14080C5X073M10	7x3x1	17,3	21,7	855	18
14080C5X123M10	12x3x1	22,5	27,4	1275	18
14080C5X163M10	16x3x1	25,2	30,3	1580	18
14080C5X193M10	19x3x1	26,5	31,6	1760	18
14080C5X243M10	24x3x1	30,6	36,1	2190	18
14080C5X033M15	3x3x1,5	15,3	19,5	695	16
14080C5X043M15	4x3x1,5	16,7	20,9	795	16
14080C5X073M15	7x3x1,5	20,4	25,1	1145	16
14080C5X123M15	12x3x1,5	26,4	31,5	1720	16
14080C5X163M15	16x3x1,5	29,6	34,8	2120	16
14080C5X193M15	19x3x1,5	31,1	36,6	2385	16
14080C5X243M15	24x3x1,5	36,4	42,7	3150	16

Other dimensions and colors available on request.

GAALSHIP® BU(i)
S13 or S13+MUD 150/250V



ELETTROTEK KABEL® GAALSHIP® BU(i)

Construction:

- Conductor:** stranded tinned copper conductor Cl. 2, acc to IEC 60228
- Insulation:** EPR, Halogen free compound + MICA glass tape acc.to IEC 60092-351, thickness acc. to IEC 60092-376
- Cores color:** acc. to NEK on request HD 308 S2
- Outer sheath:** grey (RAL 7001)
halogen-free mud resistant
thermosetting type SHF MUD, acc. to NEK IIII edit. 2009.
thickness acc. to IEC 60092-376

Resistance:



Fire resistant acc. to:
IEC 60331- 21



flame and fire retardant acc. to:
IEC 60332-3-22,
IEC 60332-1-2



Halogen free acc. to:
IEC 60754-1



Smoke emission properties acc. to:
IEC 61034-2

Technical data:

- Nominal voltage:** 0,6/1 kV
- Temperature range:** - 40°C up to +90°C
- Installation temp.:* - 20 °C
- Short circuit temperature:** +250°C
- Min. bending radius:** 8 x D

Features:

Sheathing materials acc. to: IEC 60092-359

Insulating materials acc. to: IEC 60092-351

Design guidelines acc. to:
IEC 60092-350-353 / ...-350 NEK 606 IIII ed 2009

Choice and installation of electric cables acc. to: IEC 60092-352 on request class 5

on request halogen free thermosetting type SHF2 outer sheath, acc. to IEC 60092-359 and CSA 22.2 n.38-95 cold bend-impact test at low temperature (-40°C)

acc. to NEK 606 IIII ed. 2009,
Halogen free & MUD resistance cables,
for the marine, ship and offshore

We have possibility to provide the following Certifications on request:

Det Norske Veritas (DNV)
Lloyd's Register (LR)



Available on stock CABLE GLANDS:
see page 404 up to 416 of catalogue.

Part no.	No.of pairs/triples x cross section n x mm ²	Outer-Ø ca.mm ± 10%	Copper weight kg/km	Cable weight approx. kg/km	AWG no.*)
14100C5X012M07	1x2x0,75	8,2	18	115	19
14100C5X022M07	2x2x0,75	10,5	36	215	19
14100C5X042M07	4x2x0,75	13,2	54	300	19
14100C5X072M07	7x2x0,75	16	72	455	19
14100C5X082M07	8x2x0,75	17,3	144	505	19
14100C5X122M07	12x2x0,75	21,1	216	715	19
14100C5X162M07	16x2x0,75	23,5	288	925	19
14100C5X192M07	19x2x0,75	24,8	342	1045	19
14100C5X242M07	24x2x0,75	28,6	432	1330	19
14100C5X322M07	32x2x0,75	31,7	576	1680	19
14100C5X012M10	1x2x1	8,6	23	135	18
14100C5X022M10	2x2x1	11,1	45	250	18
14100C5X042M10	4x2x1	14	90	355	18
14100C5X072M10	7x2x1	16,9	158	535	18
14100C5X082M10	8x2x1	18,5	180	610	18
14100C5X122M10	12x2x1	22,3	270	850	18

GAALSHIP® OFFSHORE CABLES

GAALSHIP® BU(i)
S13 or S13+MUD 150/250 V



ELETTROTEK KABEL® GAALSHIP® BU(i)

Part no.	No. of pairs/triples x cross section n x mm ²	Outer-Ø ca. mm ± 10%	Copper weight kg/km	Cable weight approx. kg/km	AWG no. *)
14100C5X162M10	16x2x1	24,9	360	1105	18
14100C5X192M10	19x2x1	26,5	428	1265	18
14100C5X242M10	24x2x1	30,5	540	1615	18
14100C5X322M10	32x2x1	33,8	720	2040	18
14100C5X012M15	1x2x1,5	9,6	32	165	16
14100C5X022M15	2x2x1,5	12,6	63	320	16
14100C5X042M15	4x2x1,5	16,1	126	460	16
14100C5X072M15	7x2x1,5	19,4	221	700	16
14100C5X082M15	8x2x1,5	21,3	252	790	16
14100C5X122M15	12x2x1,5	25,7	378	1110	16
14100C5X162M15	16x2x1,5	28,9	504	1460	16
14100C5X192M15	19x2x1,5	30,5	599	1655	16
14100C5X242M15	24x2x1,5	35,3	756	2125	16
14100C5X322M15	32x2x1,5	39,1	1022	2690	16
14100C5X012M25	1x2x2,5	10,5	50	200	14
14100C5X013M07	1x3x0,75	8,6	25	130	19
14100C5X033M07	3x3x0,75	13,8	75	310	19
14100C5X043M07	4x3x0,75	15,1	99	375	19
14100C5X073M07	7x3x0,75	18,3	174	570	19
14100C5X123M07	12x3x0,75	24,4	297	925	19
14100C5X163M07	16x3x0,75	27,3	396	1195	19
14100C5X193M07	19x3x0,75	29	471	1370	19
14100C5X243M07	24x3x0,75	33,7	594	1760	19
14100C5X013M10	1x3x1	9,1	32	150	18
14100C5X033M10	3x3x1	14,7	95	370	18
14100C5X043M10	4x3x1	16,1	126	450	18
14100C5X073M10	7x3x1	19,7	221	705	18
14100C5X123M10	12x3x1	26	378	1125	18
14100C5X163M10	16x3x1	29,2	504	1465	18
14100C5X193M10	19x3x1	31	599	1685	18
14100C5X243M10	24x3x1	36,1	756	2155	18
14100C5X013M15	1x3x1,5	10,1	45	185	16
14100C5X033M15	3x3x1,5	16,8	135	480	16
14100C5X043M15	4x3x1,5	18,4	180	590	16
14100C5X073M15	7x3x1,5	22,6	315	920	16
14100C5X123M15	12x3x1,5	30	540	1485	16
14100C5X163M15	16x3x1,5	33,6	720	1935	16
14100C5X193M15	19x3x1,5	35,7	855	2220	16
14100C5X243M15	24x3x1,5	41,7	1080	2865	16
14100C5X013M25	1x3x2,5	11	72	230	14

Other dimensions and colors available on request.

GAALSHIP® BFOU(i)

S3 or S3/S7 150/250 V



Construction:

Conductor:	stranded tinned copper conductor Cl. 2, acc to IEC 60228
Insulation:	EPR, Halogen free compound + MICA glass tape acc.to IEC 60092-351, thickness acc. to IEC 60092-376
Cores color:	pair: black- light blue triple: black- light blue - brown
Stranding:	cores lay-up in pairs, triples, laying-up of pairs, triples
Screen:	individual screen, copper/polyester tape with tinned copper stranded drain wire and synthetic tape.
Inner sheath:	halogen-free compound Indicative thickness acc. to IEC 60092-376
Armouring:	tinned copper wires braid acc. to IEC 60092-350
Outer sheath:	grey (RAL 7001) halogen-free mud resistant thermosetting type SHF MUD, acc. to NEK IIII edit. 2009. thickness acc. to IEC 60092-376

Technical data:

Nominal voltage:	150/250 V
Temperature range:	- 40°C up to +90°C
<i>Installation temp.:</i>	- 20 °C
Short circuit temperature:	+250°C
Min. bending radius:	8 x D

Resistance:



Fire resistant acc. to:
IEC 60331- 21



flame and fire retardant acc. to:
IEC 60332-3-22,
IEC 60332-1-2



Halogen free acc. to:
IEC 60754-1



Smoke emission properties acc. to:
IEC 61034-2

Features:

Sheathing materials acc. to: IEC 60092-359
Insulating materials acc. to: IEC 60092-351
Design guidelines acc. to:
IEC 60092-350-376 / ...-350 NEK 606 IIII ed 2009
Choice and installation of electric cables acc. to: IEC 60092-352
on request class 5
on request halogen free thermosetting type SHF2 outer sheath,
acc. to IEC 60092-359 and CSA 22.2 n.38-95
cold bend-impact test at low temperature (-40°C)
acc. to NEK 606 IIII ed. 2009,
Halogen free & MUD resistance cables,
for the marine, ship and offshore

We have possibility to provide the following Certifications on request:

Det Norske Veritas (DNV)

Lloyd's Register (LR)



Available on stock CABLE GLANDS:
see page 404 up to 416 of catalogue.

GAALSHIP® OFFSHORE CABLES

GAALSHIP® BFOU(i)

S3 or S3/S7 150/250 V



Part no.	No. of pairs/triples x cross section n x mm ²	Outer-Ø ca. mm ± 10%	Cable weight approx. kg/km	AWG no. *)
14120C5X012M07	1x2x0,75	11,5	235	19
14120C5X022M07	2x2x0,75	14,6	415	19
14120C5X042M07	4x2x0,75	17,9	570	19
14120C5X072M07	7x2x0,75	20,6	775	19
14120C5X082M07	8x2x0,75	22,1	855	19
14120C5X122M07	12x2x0,75	26,2	1155	19
14120C5X162M07	16x2x0,75	28,8	1425	19
14420C5X192M07	19x2x0,75	30,3	1585	19
14120C5X242M07	24x2x0,75	34,5	1990	19
14120C5X322M07	32x2x0,75	37,8	2500	19
14120C5X012M10	1x2x1	11,9	255	18
14120C5X022M10	2x2x1	15,2	460	18
14120C5X042M10	4x2x1	18,6	635	18
14120C5X072M10	7x2x1	21,5	870	18
14120C5X082M10	8x2x1	23,6	995	18
14120C5X122M10	12x2x1	27,4	1310	18
14120C5X162M10	16x2x1	30,2	1630	18
14120C5X192M10	19x2x1	31,8	1840	18
14120C5X242M10	24x2x1	36,4	2345	18
14120C5X322M10	32x2x1	39	2895	18
14120C5X012M15	1x2x1,5	13,1	305	16
14120C5X022M15	2x2x1,5	16,8	555	16
14120C5X042M15	4x2x1,5	20,7	780	16
14120C5X072M15	7x2x1,5	24,5	1110	16
14120C5X082M15	8x2x1,5	26,5	1235	16
14120C5X122M15	12x2x1,5	31,2	1690	16
14120C5X162M15	16x2x1,5	34,2	2065	16
14120C5X192M15	19x2x1,5	36,6	2405	16
14120C5X242M15	24x2x1,5	41,8	3090	16
14120C5X322M15	32x2x1,5	45,4	3695	16
14120C5X012M25	1x2x2,5	14	350	14
14120C5X013M07	1x3x0,75	11,9	255	19
14120C5X033M07	3x3x0,75	18,4	590	19
14120C5X043M07	4x3x0,75	19,7	685	19
14120C5X073M07	7x3x0,75	23,6	970	19
14120C5X123M07	12x3x0,75	29,6	1445	19
14120C5X163M07	16x3x0,75	32,6	1780	19
14120C5X193M07	19x3x0,75	34,4	1995	19
14120C5X243M07	24x3x0,75	39,6	2590	19
14120C5X013M10	1x3x1	12,6	285	18
14120C5X033M10	3x3x1	19,3	675	18
14120C5X043M10	4x3x1	20,9	785	18
14120C5X073M10	7x3x1	24,8	1120	18
14120C5X123M10	12x3x1	31,3	1695	18
14120C5X163M10	16x3x1	34,9	2115	18
14120C5X193M10	19x3x1	36,5	2365	18
14120C5X243M10	24x3x1	42,8	3155	18
14120C5X013M15	1x3x1,5	13,6	335	16
14120C5X023M15	2x3x1,5	20,9	790	16
14120C5X033M15	3x3x1,5	21,4	810	16
14120C5X043M15	4x3x1,5	23,7	985	16
14120C5X073M15	7x3x1,5	27,7	1385	16
14120C5X123M15	12x3x1,5	35,5	2125	16
14120C5X163M15	16x3x1,5	39,7	2785	16
14120C5X193M15	19x3x1,5	42,4	3210	16
14120C5X243M15	24x3x1,5	47,8	3935	16
14120C5X013M25	1x3x2,5	14,5	390	14

Other dimensions and colors available on request.

GAALSHIP® BU(c) S14 150/250 V



ELETTROTEK KABEL® GAALSHIP® BU(c)

Construction:

Conductor:	stranded tinned copper conductor Cl. 2, acc to IEC 60228
Insulation:	EPR, Halogen free compound + MICA glass tape acc.to IEC 60092-351, thickness acc. to IEC 60092-376
Cores color:	pair: black- light blue triple: black- light blue - brown
Stranding:	cores lay-up in pairs, triples, laying-up of pairs, triples
Screen:	overall screen, copper/polyester tape with tinned copper stranded drain wire and synthetic tape.
Outer sheath:	grey (RAL 7001) halogen-free mud resistant thermosetting type SHF MUD, acc. to NEK IIII edit. 2009. thickness acc. to IEC 60092-376

Technical data:

Nominal voltage:	150/250 V
Temperature range:	- 40°C up to +90°C
Installation temp.:	- 20 °C
Short circuit temperature:	+250°C
Min. bending radius:	8 x D

Resistance:



Fire resistant acc. to:
IEC 60331- 21



flame and fire retardant acc. to:
IEC 60332-3-22,
IEC 60332-1-2



Halogen free acc. to:
IEC 60754-1



Smoke emission properties acc. to:
IEC 61034-2

Features:

Sheathing materials acc. to: IEC 60092-359

Insulating materials acc. to: IEC 60092-351

Design guidelines acc. to:
IEC 60092-350-376 / ...-350 NEK 606 IIII ed 2009

Choice and installation of electric cables acc. to: IEC 60092-352
on request class 5

on request halogen free thermosetting type SHF2 outer sheath,
acc. to IEC 60092-359 and CSA 22.2 n.38-95
cold bend-impact test at low temperature (-40°C)

acc. to NEK 606 IIII ed. 2009,
Halogen free & MUD resistance cables,
for the marine, ship and offshore

We have possibility to provide the following Certifications on request:

Det Norske Veritas (DNV)

Lloyd's Register (LR)



Available on stock CABLE GLANDS:
see page 404 up to 416 of catalogue.

GAALSHIP® OFFSHORE CABLES

GAALSHIP® BU(c)
S14 I50/250V



ELETTROTEK KABEL® GAALSHIP® BU(c)

Part no.	No. of pairs/triples x cross section n x mm ²	Outer-Ø ca. mm ± 10%	Copper weight kg/km	Cable weight approx. kg/km	AWG no. *)
14140C5X022M07	2x2x0,75	10,2	32	195	19
14140C5X042M07	4x2x0,75	12,5	59	250	19
14140C5X072M07	7x2x0,75	15	99	360	19
14140C5X082M07	8x2x0,75	16,3	113	405	19
14140C5X122M07	12x2x0,75	19,5	167	550	19
14140C5X162M07	16x2x0,75	21,8	221	700	19
14140C5X192M07	19x2x0,75	23,2	261	790	19
14140C5X242M07	24x2x0,75	26,7	329	995	19
14140C5X322M07	32x2x0,75	29,6	437	1235	19
14140C5X022M10	2x2x1	10,7	41	220	18
14140C5X042M10	4x2x1	13,3	77	295	18
14140C5X072M10	7x2x1	16	131	425	18
14140C5X082M10	8x2x1	17,3	149	475	18
14140C5X122M10	12x2x1	20,8	221	655	18
14140C5X162M10	16x2x1	23,3	293	835	18
14140C5X192M10	19x2x1	24,7	347	950	18
14140C5X242M10	24x2x1	28,8	437	1210	18
14140C5X322M10	32x2x1	31,8	581	1505	18
14140C5X022M15	2x2x1,5	12,1	59	285	16
14140C5X042M15	4x2x1,5	15,2	113	390	16
14140C5X072M15	7x2x1,5	18,4	194	575	16
14140C5X082M15	8x2x1,5	20	221	650	16
14140C5X122M15	12x2x1,5	24,3	329	905	16
14140C5X162M15	16x2x1,5	27,2	437	1160	16
14140C5X192M15	19x2x1,5	28,6	518	1205	16
14140C5X242M15	24x2x1,5	33,5	653	1680	16
14140C5X322M15	32x2x1,5	37	869	2105	16
14140C5X033M07	3x3x0,75	13,1	66	275	19
14140C5X043M07	4x3x0,75	14,4	86	330	19
14140C5X073M07	7x3x0,75	17,4	147	485	19
14140C5X123M07	12x3x0,75	22,9	248	755	19
14140C5X163M07	16x3x0,75	25,6	329	975	19
14140C5X193M07	19x3x0,75	27,2	390	1105	19
14140C5X243M07	24x3x0,75	31,6	491	1415	19
14140C5X033M10	3x3x1	14	86	320	18
14140C5X043M10	4x3x1	15,3	113	390	18
14140C5X073M10	7x3x1	18,6	194	580	18
14140C5X123M10	12x3x1	24,4	329	910	18
14140C5X163M10	16x3x1	27,3	437	1170	18
14140C5X193M10	19x3x1	29	518	1335	18
14140C5X243M10	24x3x1	33,7	653	180	18
14140C5X033M15	3x3x1,5	16	126	430	16
14140C5X043M15	4x3x1,5	17,7	167	525	16
14140C5X073M15	7x3x1,5	21,5	288	795	16
14140C5X123M15	12x3x1,5	28,5	491	1265	16
14140C5X163M15	16x3x1,5	31,9	653	1640	16
14140C5X193M15	19x3x1,5	33,8	774	1865	16
14140C5X243M15	24x3x1,5	39,3	977	2385	16

Other dimensions and colors available on request.

GAALSHIP® BFOU(c) S4 or S4/S8 150/250 V



ELETTROTEK KABEL® GAALSHIP® BFOU (c)

Construction:

Conductor:	stranded tinned copper conductor Cl. 2, acc to IEC 60228
Insulation:	EPR, Halogen free compound + MICA glass tape acc.to IEC 60092-351, thickness acc. to IEC 60092-376
Cores color:	pair: black- light blue triple: black- light blue - brown
Stranding:	cores lay-up in pairs, triples, laying-up of pairs, triples
Screen:	overall screen, copper/polyester tape with tinned copper stranded drain wire and synthetic tape.
Inner sheath:	halogen-free compound Indicative thickness acc. to IEC 60092-376
Armouring:	tinned copper wires braid acc. to IEC 60092-350
Outer sheath:	grey (RAL 7001) halogen-free mud resistant thermosetting type SHF MUD, acc. to NEK IIII edit. 2009. thickness acc. to IEC 60092-376

Technical data:

Nominal voltage:	150/250 V
Temperature range:	- 40°C up to +90°C
Installation temp.:	- 20 °C
Short circuit temperature:	+250°C
Min. bending radius:	8 x D

Resistance:



Fire resistant acc. to:
IEC 60331- 21



flame and fire retardant acc. to:
IEC 60332-3-22,
IEC 60332-1-2



Halogen free acc. to:
IEC 60754-1



Smoke emission properties acc. to:
IEC 61034-2

Features:

Sheathing materials acc. to: IEC 60092-359
Insulating materials acc. to: IEC 60092-351
Design guidelines acc. to:
IEC 60092-350-376 / ...-350 NEK 606 IIII ed 2009
Choice and installation of electric cables acc. to: IEC 60092-352
on request class 5
on request halogen free thermosetting type SHF2 outer sheath,
acc. to IEC 60092-359 and CSA 22.2 n.38-95
cold bend-impact test at low temperature (-40°C)
acc. to NEK 606 IIII ed. 2009,
Halogen free & MUD resistance cables,
for the marine, ship and offshore

We have possibility to provide the following Certifications on request:

Det Norske Veritas (DNV)

Lloyd's Register (LR)



Available on stock CABLE GLANDS:
see page 404 up to 416 of catalogue.

GAALSHIP® OFFSHORE CABLES

GAALSHIP® BFOU(c)

S4 or S4/S8 150/250 V



ELETTROTEK KABEL® GAALSHIP® BFOU (c)



Part no.	No. of pairs/triples x cross section n x mm ²	Ø under armour ca. mm ± 10%	Outer-Ø ca. mm ± 10%	Cable weight approx. kg/km	AWG no. *)
14160C5X022M07	2x2x0,75	10,3	14,3	350	19
14160C5X042M07	4x2x0,75	12,6	16,8	495	19
14160C5X072M07	7x2x0,75	15,4	19,8	680	19
14160C5X082M07	8x2x0,75	16,5	20,9	725	19
14160C5X122M07	12x2x0,75	19,9	24,6	960	19
14160C5X162M07	16x2x0,75	22	26,9	1150	19
14160C5X192M07	19x2x0,75	23,2	28,3	1270	19
14160C5X242M07	24x2x0,75	26,8	32,2	1595	19
14160C5X322M07	32x2x0,75	29,6	35,7	1975	19
14160C5X022M10	2x2x1	10,8	14,8	385	18
14160C5X042M10	4x2x1	13,8	18	570	18
14160C5X072M10	7x2x1	16,4	20,8	755	18
14160C5X082M10	8x2x1	17,6	22,2	830	18
14160C5X122M10	12x2x1	21,2	26,1	1105	18
14160C5X162M10	16x2x1	23,5	28,6	1330	18
14160C5X192M10	19x2x1	24,9	30	1475	18
14160C5X242M10	24x2x1	28,6	34,1	1815	18
14160C5X322M10	32x2x1	31,6	37,9	2330	18
14160C5X022M15	2x2x1,5	12,2	16,4	515	16
14160C5X042M15	4x2x1,5	15,7	19,9	705	16
14160C5X072M15	7x2x1,5	19	23,7	975	16
14160C5X082M15	8x2x1,5	20,4	25,3	1080	16
14160C5X122M15	12x2x1,5	24,5	29,6	1425	16
14160C5X162M15	16x2x1,5	27,2	32,5	1745	16
14160C5X192M15	19x2x1,5	28,6	34,1	1925	16
14160C5X242M15	24x2x1,5	33,1	39,4	2510	16
14160C5X322M15	32x2x1,5	37	43,7	3120	16
14160C5X033M07	3x3x0,75	13,7	17,9	550	19
14160C5X043M07	4x3x0,75	14,8	19	620	19
14160C5X073M07	7x3x0,75	17,7	22,1	825	19
14160C5X123M07	12x3x0,75	23,1	28,2	1240	19
14160C5X163M07	16x3x0,75	25,8	31,1	1555	19
14160C5X193M07	19x3x0,75	27,2	32,4	1690	19
14160C5X243M07	24x3x0,75	31	37,5	2165	19
14160C5X033M10	3x3x1	14,5	18,7	610	18
14160C5X043M10	4x3x1	15,8	20	700	18
14160C5X073M10	7x3x1	19,2	23,7	970	18
14160C5X123M10	12x3x1	24,8	29,9	1445	18
14160C5X163M10	16x3x1	27,5	32,8	1775	18
14160C5X193M10	19x3x1	29,2	34,7	1980	18
14160C5X243M10	24x3x1	33,5	39,8	2565	18
14160C5X033M15	3x3x1,5	16,4	20,8	760	16
14160C5X043M15	4x3x1,5	17,9	22,3	870	16
14160C5X073M15	7x3x1,5	21,9	26,8	1240	16
14160C5X123M15	12x3x1,5	28,5	33,8	1865	16
14160C5X163M15	16x3x1,5	31,9	38	2415	16
14160C5X193M15	19x3x1,5	33,6	39,9	2720	16
14160C5X243M15	24x3x1,5	39,3	46	3440	16

Other dimensions and colors available on request.



“BS” Normatives

“BS” normatives

GAALSHIP® OFFSHORE cables according to:

BS 6883:1999:	Elastomer insulated cables for fixed wiring in ship and on mobile and offshore platform.
BS 7917:1999:	Elastomer insulated fire resistant cables for fixed wiring in ship and on mobile and offshore platform.
BS 7655:	Insulating and sheathing materials of electric cables.
IEC 60092-350:	General construction and test requirement.
IEC 60092-352:	Choice and installation of electric cables.
IEC 60228:	Conductors of insulated cables.
IEC 60331 :	Fire resisting characteristics of electrical cables.
IEC 60332-1-2:	Test on a single vertical insulated wire or cable.
IEC 60332-3-22:	Test on bunched wires or cables.
IEC 60754-1/60754-2:	Test on gases evolved during combustion of materials from cable.
IEC 60811:	Common test methods for insulating and sheathing materials of electric cables.
IEC 61034-1/61034-2:	Measurements of smoke density of electric cable burning under defined conditions.

Legend

(acc. to BS 6883/BS 7917)

Cable element	Code
Armoured: Galvanized steel wires braid (tinned phosphorous bronze for 1 core cable)	G
Instrumentation cables	T
Individual screen (on each pair/triple/quad)	I
Overall screen	O
Fire resisting	- FR
In addition a combination of letters and numbers is used, as in BS 6883 / BS 7917, to define the cable type	
Halogen free cables	SW4
Reduced halogen cables	SW2

Cores identification

Insulation colour scheme:

0,6/1 kV Power and control cables

According to BS 6883/BS 7917		Alternatives:
1 core	Red or Black	White and numbered
2 cores	Red - Black	White and numbered
3 cores	Red - Yellow - Blue	White and numbered
4 cores	Red - Yellow - Blue - Black	White and numbered
above 4 cores	White whit black numbered	

150/250V Instrumentation cables

N. of cores	Cores colour
Pair	Black - White
Triple	Black - White - Red
Quad	Black - White - Red - Blue

Pairs/Triples/Quads are numbered with numbers printed directly on the insulated conductors (1-1; 2-2; ...) or buy numbered tape

Other colours available on request

MV cables

1x...:	natural colour of the compound
3x...:	Coloured tape or thread (e.g.: red - yellow - blue)

Outer sheath colours (STANDARDS COLOURS)

Instrumentation and control	GREY
Power LV	BLACK
Power MV	RED

Other colours available on request

GAALSHIP® (RU 0,6/1 kV)

SW4 or SW2 0,6/1 kV



Construction:

- Conductor:** stranded tinned copper conductor Cl. 2, acc to IEC 60228
- Insulation:** Halogen free EPR, type GP4 acc. to BS 7655 1-2
- Cores color:** acc. to BS 6883/ BS 7917 (off-white with black numbers printed)
- Outer sheath:** black (RAL 9005), halogen free thermosetting type SW4 acc. to BS 7655 2.6, oil and tear resistant

Technical data:

- Nominal voltage:** 0,6/1 kV
- Temperature range:** - 40°C up to +90°C
- Installation temp.:** - 20 °C
- Short circuit temperature:** +250°C
- Min. bending radius:** D < 25mm: = 4 x D
D > 25 mm: = 6 x D

Resistance:



Flame and fire retardant acc. to:
IEC 60332-1-2,
IEC 60332-3-22



Halogen free acc. to:
IEC 60754-1/2



Smoke emission properties acc. to:
IEC 61034-1/2

Features:

- Sheathing materials acc. to: BS 7655 2.6
- Insulating materials acc. to: BS 7655 1.2
- Design guidelines acc. to: BS 6883:1999
- Choice and installation of electric cables acc. to: IEC 60092-352 on request class 5
- on request reduced halogen thermosetting type SW2 outer sheath, acc. to BS 7655 2.6, oil and tear resistant

We have possibility to provide the following Certifications on request:

- Bureau Veritas (BV)
- Lloyd's Register (LR)
- Registro Italiano Navale (RINA)
- American Bureau of Shipping (ABS)



Available on stock CABLE GLANDS: see page 404 up to 416 of catalogue.

Part no.	No. of cores x cross section n x mm ²	Outer-Ø ca. mm ± 10%	Copper weight kg/km	Cable weight approx. kg/km	AWG no.®)
18010G7L010M40	1x4	6,9	38,4	95	12
18010G7L010M60	1x6	7,5	57,6	120	10
18010G7L010M61	1x10	8,4	96	165	8
18010G7L010M62	1x16	9,6	153,6	230	6
18010G7L010M63	1x25	11,9	240	345	4
18010G7L010M64	1x35	12,8	336	445	2
18010G7L010M65	1x50	14,6	480	600	1
18010G7L010M66	1x70	16,4	672	810	2/0
18010G7L010M67	1x95	18,7	912	1100	3/0
18010G7L010M68	1x120	20,8	1152	1360	4/0
18010G7L010M69	1x150	22,9	1140	1650	250 MCM
18010G7L010M70	1x185	25,3	1776	2070	350 MCM
18010G7L010M71	1x240	28,5	2304	2670	450 MCM
18010G7L010M72	1x300	31,6	2880	3340	550 MCM
18010G7D020M15	2x1,5	8,9	28,8	125	16
18010G7D020M25	2x2,5	9,7	48	160	14
18010G7D020M40	2x4	11,8	76,8	235	12
18010G7D020M60	2x6	12,9	115,2	300	10
18010G7D020M61	2x10	15	192	415	8
18010G7D020M62	2x16	17,3	307,2	590	6
18010G7D020M63	2x25	21,6	480	890	4
18010G7D020M64	2x35	23,6	672	1150	2
18010G7D020M65	2x50	27,5	960	1570	1

GAALSHIP® OFFSHORE CABLES

GAALSHIP® (RU 0,6/1 kV)
SW4 or SW2 0,6/1 kV



Part no.	No. of cores x cross section n x mm ²	Outer-Ø ca. mm ± 10%	Copper weight kg/km	Cable weight approx. kg/km	AWG no. *)
18010G7D020M66	2x70	31,1	1344	2140	2/0
18010G7D020M67	2x95	35,7	1824	2930	3/0
18010G7D020M68	2x120	39,4	2304	3600	4/0
18010G7D030M15	3x1,5	9,1	43,2	150	16
18010G7D030M25	3x2,5	10,3	72	190	14
18010G7D030M40	3x4	12,5	115,2	280	12
18010G7D030M60	3x6	13,8	172,8	370	10
18010G7D030M61	3x10	16	288	505	8
18010G7D030M62	3x16	18,4	460,8	750	6
18010G7D030M63	3x25	23,6	720	1150	4
18010G7D030M64	3x35	25,4	1008	1490	2
18010G7D030M65	3x50	29,1	1440	2030	1
18010G7D030M66	3x70	33,5	2016	2790	2/0
18010G7D030M67	3x95	38,4	2736	3820	3/0
18010G7D030M68	3x120	42,5	3456	4710	4/0
18010G7D030M69	3x150	46,9	4320	5710	250 MCM
18010G7D030M70	3x185	52,3	5328	7180	350 MCM
18010G7D030M71	3x240	59,1	6912	9310	450 MCM
18010G7D040M15	4x1,5	10,2	57,6	175	16
18010G7D040M25	4x2,5	11,3	96	225	14
18010G7D040M40	4x4	13,7	153,6	340	12
18010G7D040M60	4x6	15,3	230,4	465	10
18010G7D040M61	4x10	17,7	384	640	8
18010G7D040M62	4x16	20,6	614,4	960	6
18010G7D040M63	4x25	25,8	960	1550	4
18010G7D040M64	4x35	28,1	1344	1920	2
18010G7D040M65	4x50	30,8	1920	2600	1
18010G7D040M66	4x70	37,1	2688	3570	2/0
18010G7D040M67	4x95	42,7	3648	4900	3/0
18010G7D040M68	4x120	47,2	4608	6070	4/0
18010G7D040M69	4x150	52,4	5760	7360	250 MCM
18010G7D040M70	4x185	58,2	7104	9260	350 MCM
18010G7D040M71	4x240	66,1	9216	12030	450 MCM
18010G7D050M15	5x1,5	11,2	72	200	16
18010G7D070M15	7x1,5	12,3	100,8	255	16
18010G7D120M15	12x1,5	16,2	172,8	405	16
18010G7D190M15	19x1,5	19	273,6	600	16
18010G7D270M15	27x1,5	22,7	388,6	850	16
18010G7D370M15	37x1,5	26	532,8	1120	16
18010G7D050M25	5x2,5	12,3	120	270	14
18010G7D070M25	7x2,5	13,5	168	335	14
18010G7D120M25	12x2,5	18,1	288	550	14
18010G7D190M25	19x2,5	21,4	456	830	14
18010G7D270M25	27x2,5	25,7	648	1160	14
18010G7D370M25	37x2,5	29,5	888	1530	14

Other dimensions and colors available on request.

GAALSHIP® G (RFCU 0,6/1 kV)

SW4 or SW2 0,6/1 kV



Construction:

- Conductor:** stranded tinned copper conductor Cl. 2, acc to IEC 60228
- Insulation:** Halogen free EPR, type GP4 acc. to BS 7655 1-2
- Cores color:** acc. to BS 6883/ BS 7917 (off-white with black numbers printed)
- Inner sheath:** halogen free thermosetting type SW4, acc. to BS 7655 2.6, oil resistant
- Armouring:** galvanized steel wires braid or tinned phosphorous bronze wires braid (single core)
- Outer sheath:** black (RAL 9005), halogen free thermosetting type SW4 acc. to BS 7655 2.6, oil resistant

Technical data:

- Nominal voltage:** 0,6/1 kV
- Temperature range:** - 40°C up to +90°C
- Installation temp.:** - 20 °C
- Short circuit temperature:** +250°C
- Min. bending radius:** D < 25mm: = 4 x D
D > 25 mm: = 6 x D

Resistance:

- Flame and fire retardant acc. to:**
IEC 60332-1-2,
IEC 60332-3-22
- Halogen free acc. to:**
IEC 60754-1/2
- Smoke emission properties acc. to:**
IEC 61034-1/2

Features:

- Sheathing materials acc. to: BS 7655 2.6
- Insulating materials acc. to: BS 7655 1.2
- Design guidelines acc. to: BS 6883:1999
- Choice and installation of electric cables acc. to: IEC 60092-352 on request class 5
- on request tinned copper wire braid armour
- on request reduced halogen thermosetting type SW2 outer sheath, acc. to BS 7655 2.6, oil and tear resistant

We have possibility to provide the following Certifications on request:

- Bureau Veritas (BV)
- Lloyd's Register (LR)
- Registro Italiano Navale (RINA)
- American Bureau of Shipping (ABS)



Available on stock CABLE GLANDS:
see page 404 up to 416 of catalogue.

Part no.	No. of cores x cross section n x mm ²	Ø under armour ca. mm ± 10%	Outer-Ø ca. mm ± 10%	Cable weight approx. kg/km	AWG no. *)
18030G7L010M40	1x4	6,9	10,8	220	12
18030G7L010M60	1x6	7,5	11,3	250	10
18030G7L010M61	1x10	8,4	12,5	310	8
18030G7L010M62	1x16	9,6	13,7	400	6
18030G7L010M63	1x25	11,9	16,2	570	4
18030G7L010M64	1x35	12,8	17,3	660	2
18030G7L010M65	1x50	14,6	19	870	1
18030G7L010M66	1x70	16,4	21,2	1110	2/0
18030G7L010M67	1x95	18,7	23,7	1460	3/0
18030G7L010M68	1x120	20,8	25,8	1770	4/0
18030G7L010M69	1x150	22,9	28,1	2110	250 MCM
18030G7L010M70	1x185	25,3	31,7	2720	350 MCM
18030G7L010M71	1x240	28,5	35	3410	450 MCM
18030G7L010M72	1x300	31,6	38,1	4180	550 MCM

GAALSHIP® OFFSHORE CABLES

GAALSHIP® G (RFCU 0,6/1 kV)

SW4 or SW2 0,6/1 kV



ELETTROTEK KABEL® GAALSHIP® G (RFCU 0,6/1kV)

Part no.	No. of cores x cross section n x mm ²	Ø under armour ca. mm ± 10%	Outer-Ø ca. mm ± 10%	Cable weight approx. kg/km	AWG no. *)
18030G7D020M15	2x1,5	8,9	13	270	16
18030G7D020M25	2x2,5	9,7	13,8	320	14
18030G7D020M40	2x4	11,8	16,1	430	12
18030G7D020M60	2x6	12,9	17,3	530	10
18030G7D020M61	2x10	15	19,4	660	8
18030G7D020M62	2x16	17,3	22	840	6
18030G7D020M63	2x25	21,6	26,7	1310	4
18030G7D020M64	2x35	23,6	28,9	1600	2
18030G7D020M65	2x50	27,5	33,6	2240	1
18030G7D020M66	2x70	31,1	37,6	2900	2/0
18030G7D020M67	2x95	35,7	43	3860	3/0
18030G7D020M68	2x120	39,4	42,9	4650	4/0
18030G7D030M15	3x1,5	9,1	13,5	305	16
18030G7D030M25	3x2,5	10,3	14,5	360	14
18030G7D030M40	3x4	12,5	16,8	495	12
18030G7D030M60	3x6	13,8	18,2	600	10
18030G7D030M61	3x10	16	20,8	810	8
18030G7D030M62	3x16	18,4	23,3	1070	6
18030G7D030M63	3x25	23,6	28,5	1620	4
18030G7D030M64	3x35	25,4	31,8	2130	2
18030G7D030M65	3x50	29,1	35,5	2750	1
18030G7D030M66	3x70	33,5	40	3660	2/0
18030G7D030M67	3x95	38,4	45,8	4740	3/0
18030G7D030M68	3x120	42,5	50	5950	4/0
18030G7D030M69	3x150	46,9	55,1	7120	250 MCM
18030G7D030M70	3x185	52,3	61	8820	350 MCM
18030G7D030M71	3x240	59,1	68	11280	450 MCM
18030G7D040M15	4x1,5	10,2	15,5	350	16
18030G7D040M25	4x2,5	11,3	18,1	410	14
18030G7D040M40	4x4	13,7	20	570	12
18030G7D040M60	4x6	15,3	22,7	730	10
18030G7D040M61	4x10	17,7	25,5	990	8
18030G7D040M62	4x16	20,6	32,1	1330	6
18030G7D040M63	4x25	25,8	34,7	2150	4
18030G7D040M64	4x35	28,1	34,7	2600	2
18030G7D040M65	4x50	30,8	39,2	3410	1
18030G7D040M66	4x70	37,1	44,5	4530	2/0
18030G7D040M67	4x95	42,7	50,3	5940	3/0
18030G7D040M68	4x120	47,2	55,5	7390	4/0
18030G7D050M15	5x1,5	11,2	15,3	395	16
18030G7D070M15	7x1,5	12,3	16,5	460	16
18030G7D120M15	12x1,5	16,2	21	680	16
18030G7D190M15	19x1,5	19	24	930	16
18030G7D270M15	27x1,5	22,7	28,5	1270	16
18030G7D370M15	37x1,5	26	32,3	1740	16
18030G7D050M25	5x2,5	12,3	16,7	480	14
18030G7D070M25	7x2,5	13,5	17,9	570	14
18030G7D120M25	12x2,5	18,1	23	880	14
18030G7D190M25	19x2,5	21,4	26,4	1220	14
18030G7D270M25	27x2,5	25,7	31,7	1800	14
18030G7D370M25	37x2,5	29,5	35,5	2310	14

Other dimensions and colors available on request.

GAALSHIP® OFFSHORE CABLES

GAALSHIP® FR



SW4 F0 (or FI) or SW2 F0 (or FI) 0,6/1 kV



Construction:

- Conductor:** stranded tinned copper conductor Cl. 2, acc to IEC 60228
- Insulation:** Halogen free EPR, type GP4 acc. to BS 7655 1-2 + MICA glass tape
- Cores color:** acc. to BS 6883/ BS 7917 (off-white with black numbers printed)
- Outer sheath:** black (RAL 9005), halogen free thermosetting type SW4 acc. to BS 7655 2.6, oil resistant

Resistance:

-  **Fire resistant acc. to:** IEC 60331-21
-  **Flame and fire retardant acc. to:** IEC 60332-1-2, IEC 60332-3-22
-  **Halogen free acc. to:** IEC 60754-1/2
-  **Smoke emission properties acc. to:** IEC 61034-1/2

Technical data:

- Nominal voltage:** 0,6/1 kV
- Temperature range:** - 40°C up to +90°C
- Installation temp.:** - 20 °C
- Short circuit temperature:** +250°C
- Min. bending radius:** D < 25mm: = 4 x D
D > 25 mm: = 6 x D

Features:

- Sheathing materials acc. to: BS 7655 2.6
- Insulating materials acc. to: BS 7655 1.2
- Design guidelines acc. to: BS 6883:1999
- Choice and installation of electric cables acc. to: IEC 60092-352 on request class 5
- on request tinned copper wire braid armour
- on request reduced halogen thermosetting type SW2 outer sheath, acc. to BS 7655 2.6, oil and tear resistant

We have possibility to provide the following Certifications on request:

- Bureau Veritas (BV)
- Lloyd's Register (LR)
- Registro Italiano Navale (RINA)
- American Bureau of Shipping (ABS)

 **Available on stock CABLE GLANDS: see page 404 up to 416 of catalogue.**

Part no.	No. of cores x cross section n x mm ²	Outer-Ø ca. mm ± 10%	Copper weight kg/km	Cable weight approx. kg/km	AWG no. *)
18050G7L010M40	1x4	7,4	38,4	90	12
18050G7L010M60	1x6	7,9	57,6	135	10
18050G7L010M61	1x10	8,8	96	180	8
18050G7L010M62	1x16	10	153,6	315	6
18050G7L010M63	1x25	12,4	240	550	4
18050G7L010M64	1x35	13,2	336	715	2
18050G7L010M65	1x50	15	480	830	1
18050G7L010M66	1x70	16,8	672	1110	2/0
18050G7L010M67	1x95	19,1	912	1470	3/0
18050G7L010M68	1x120	21,2	1152	2130	4/0
18050G7L010M69	1x150	23,3	1140	2475	250 MCM
18050G7L010M70	1x185	25,7	1776	2870	350 MCM
18050G7L010M71	1x240	28,9	2304	3120	450 MCM
18050G7L010M72	1x300	32	2880	4060	550 MCM

GAALSHIP® OFFSHORE CABLES

GAALSHIP® FR

SW4 F0 (or FI) or SW2 F0 (or FI) 0,6/1 kV



Part no.	No. of cores x cross section n x mm ²	Outer-Ø ca. mm ± 10%	Copper weight kg/km	Cable weight approx. kg/km	AWG no. *)
18050G7D020M15	2x1,5	9,7	28,8	145	16
18050G7D020M25	2x2,5	10,6	48	180	14
18050G7D020M40	2x4	12,65	76,8	260	12
18050G7D020M60	2x6	13,8	115,2	325	10
18050G7D020M61	2x10	15,9	192	445	8
18050G7D020M62	2x16	18,1	307,2	630	6
18050G7D020M63	2x25	22,5	480	930	4
18050G7D020M64	2x35	24,4	672	1210	2
18050G7D020M65	2x50	27,9	960	1630	1
18050G7D020M66	2x70	31,9	1344	2210	2/0
18050G7D020M67	2x95	36,6	1824	3010	3/0
18050G7D020M68	2x120	40,3	2304	3690	4/0
18050G7D030M15	3x1,5	10,3	43,2	170	16
18050G7D030M25	3x2,5	11,3	72	210	14
18050G7D030M40	3x4	13,5	115,2	310	12
18050G7D030M60	3x6	14,7	172,8	395	10
18050G7D030M61	3x10	18,9	288	590	8
18050G7D030M62	3x16	19,3	460,8	830	6
18050G7D030M63	3x25	24,2	720	1270	4
18050G7D030M64	3x35	26,2	1008	1540	2
18050G7D030M65	3x50	29,9	1440	2100	1
18050G7D030M66	3x70	34,3	2016	2870	2/0
18050G7D030M67	3x95	39,2	2736	3910	3/0
18050G7D030M68	3x120	43,3	3456	4800	4/0
18050G7D030M69	3x150	47,8	4320	5810	250 MCM
18050G7D030M70	3x185	53,2	5328	7290	350 MCM
18050G7D030M71	3x240	59,9	6912	9440	450 MCM
18050G7D040M15	4x1,5	11,3	57,6	200	16
18050G7D040M25	4x2,5	12,2	96	250	14
18050G7D040M40	4x4	14,7	153,6	375	12
18050G7D040M60	4x6	16,3	230,4	495	10
18050G7D040M61	4x10	18,7	384	740	8
18050G7D040M62	4x16	22,5	614,4	1050	6
18050G7D040M63	4x25	26,8	960	1580	4
18050G7D040M64	4x35	29,1	1344	1960	2
18050G7D040M65	4x50	31,8	1920	2570	1
18050G7D040M66	4x70	33,4	2688	3530	2/0
18050G7D040M67	4x95	43,7	3648	4850	3/0
18050G7D040M68	4x120	48,2	4608	5990	4/0
18050G7D050M15	5x1,5	12,3	72	220	250 MCM
18050G7D070M15	7x1,5	13,5	100,8	285	350 MCM
18050G7D120M15	12x1,5	17,8	172,8	465	450 MCM
18050G7D190M15	19x1,5	21,1	273,6	680	16
18050G7D270M15	27x1,5	25,6	388,8	960	16
18050G7D370M15	37x1,5	28,9	532,8	1260	16
18050G7D050M25	5x2,5	13,5	120	310	16
18050G7D070M25	7x2,5	14,7	168	375	16
18050G7D120M25	12x2,5	19,8	288	610	16
18050G7D190M25	19x2,5	23,4	456	895	14
18050G7D270M25	27x2,5	28,5	648	1270	14
18050G7D370M25	37x2,5	31,8	888	1680	14

Other dimensions and colors available on request.

GAALSHIP® G FR (BFCU 0,6/1 kV)

SW4 F0 (or FI) or SW2 F0 (or FI) 0,6/1 kV





Construction:

- Conductor:** stranded tinned copper conductor Cl. 2, acc to IEC 60228
- Insulation:** Halogen free EPR, type GP4 acc. to BS 7655 1-2 + MICA glass tape
- Cores color:** acc. to BS 6883/ BS 7917 (off-white with black numbers printed)
- Inner sheath:** halogen free thermosetting type SB1, acc. to BS 7917
- Armouring:** galvanized steel wires braid or tinned phosphorous bronze wire braid (single core)
- Outer sheath:** black (RAL 9005), halogen free thermosetting type SW4 acc. to BS 7655 2.6, oil resistant

Technical data:

- Nominal voltage:** 0,6/1 kV
- Temperature range:** - 40°C up to +90°C
- Installation temp.:** - 20 °C
- Short circuit temperature:** +250°C
- Min. bending radius:** 6 x D

Resistance:

-  **Fire resistant acc. to:** IEC 60331- 21
-  **Flame and fire retardant acc. to:** IEC 60332-1-2, IEC 60332-3-22
-  **Halogen free acc. to:** IEC 60754-1/2
-  **Smoke emission properties acc. to:** IEC 61034-1/2

Features:

- Sheathing materials acc. to: BS 7655 2.6
- Insulating materials acc. to: BS 7655 1.2
- Design guidelines acc. to: BS 7917:1999
- Choice and installation of electric cables acc. to: IEC 60092-352 on request class 5
- on request tinned copper wire braid armour
- on request reduced halogen thermosetting type SW2 outer sheath, acc. to BS 7655 2.6, oil and tear resistant

We have possibility to provide the following Certifications on request:

- Bureau Veritas (BV)
- Lloyd's Register (LR)
- Registro Italiano Navale (RINA)
- American Bureau of Shipping (ABS)



Available on stock CABLE GLANDS: see page 404 up to 416 of catalogue.

Part no.	No. of cores x cross section n x mm ²	Ø under armour ca. mm ± 10%	Outer-Ø ca. mm ± 10%	Cable weight approx. kg/km	AWG no.*)
18070G7L010M40	1x4	7,4	11,1	245	12
18070G7L010M60	1x6	7,9	11,7	275	10
18070G7L010M61	1x10	8,8	12,9	355	8
18070G7L010M62	1x16	10	14	440	6
18070G7L010M63	1x25	12,4	16,5	600	4
18070G7L010M64	1x35	13,2	17,7	720	2
18070G7L010M65	1x50	15	19,4	910	1
18070G7L010M66	1x70	16,8	21,6	1170	2/0
18070G7L010M67	1x95	19,1	24,1	1510	3/0
18070G7L010M68	1x120	21,2	26,2	1830	4/0
18070G7L010M69	1x150	23,3	28,5	2160	250 MCM
18070G7L010M70	1x185	25,7	32	2790	350 MCM
18070G7L010M71	1x240	28,9	35,4	3530	450 MCM
18070G7L010M72	1x300	32	38,5	4280	550 MCM

GAALSHIP® OFFSHORE CABLES

GAALSHIP® G FR (BFCU 0,6/1 kV)

SW4 F0 (or FI) or SW2 F0 (or FI) 0,6/1 kV



ELETTROTEK KABEL® GAALSHIP® G (BFCU 0,6/1kV)

Part no.	No. of cores x cross section n x mm ²	Ø under armour ca.mm ± 10%	Outer-Ø ca.mm ± 10%	Cable weight approx. kg/km	AWG no. *)
18070G7D020M15	2x1,5	9,7	13,7	310	16
18070G7D020M25	2x2,5	10,6	14,5	355	14
18070G7D020M40	2x4	12,65	16,8	475	12
18070G7D020M60	2x6	13,8	18,1	580	10
18070G7D020M61	2x10	15,9	20,2	750	8
18070G7D020M62	2x16	18,1	22,8	980	6
18070G7D020M63	2x25	22,5	27,4	1380	4
18070G7D020M64	2x35	24,4	29,6	1710	2
18070G7D020M65	2x50	27,9	34,4	2370	1
18070G7D020M66	2x70	31,9	38,5	3100	2/0
18070G7D020M67	2x95	36,6	43,7	4020	3/0
18070G7D020M68	2x120	40,3	47,7	4870	4/0
18070G7D030M15	3x1,5	10,3	14,3	345	16
18070G7D030M25	3x2,5	11,3	15,4	405	14
18070G7D030M40	3x4	13,5	17,6	540	12
18070G7D030M60	3x6	14,7	19,1	660	10
18070G7D030M61	3x10	18,9	21,6	910	8
18070G7D030M62	3x16	19,3	24,2	1200	6
18070G7D030M63	3x25	24,2	29,3	1760	4
18070G7D030M64	3x35	26,2	32,5	2260	2
18070G7D030M65	3x50	29,9	36,4	2880	1
18070G7D030M66	3x70	34,3	41,2	3800	2/0
18070G7D030M67	3x95	39,2	46,6	4890	3/0
18070G7D030M68	3x120	43,3	51,1	6070	4/0
18070G7D030M69	3x150	47,8	56	7270	250 MCM
18070G7D030M70	3x185	53,2	61,8	8970	350 MCM
18070G7D030M71	3x240	59,9	69	1350	450 MCM
18070G7D040M15	4x1,5	11,3	15,4	395	16
18070G7D040M25	4x2,5	12,2	16,5	465	14
18070G7D040M40	4x4	14,7	19	640	12
18070G7D040M60	4x6	16,3	21	790	10
18070G7D040M61	4x10	18,7	23,6	1070	8
18070G7D040M62	4x16	22,5	26,5	1460	6
18070G7D040M63	4x25	26,8	33,1	2140	4
18070G7D040M64	4x35	29,1	35,6	2670	2
18070G7D040M65	4x50	31,8	40,1	3630	1
18070G7D040M66	4x70	33,4	45,4	4740	2/0
18070G7D040M67	4x95	43,7	51,5	6290	3/0
18070G7D040M68	4x120	48,2	56,4	7670	4/0
18070G7D050M15	5x1,5	12,3	16,5	455	250 MCM
18070G7D070M15	7x1,5	13,5	17,7	530	350 MCM
18070G7D120M15	12x1,5	17,8	22,6	790	450 MCM
18070G7D190M15	19x1,5	21,1	25,9	1080	16
18070G7D270M15	27x1,5	25,6	31	1460	16
18070G7D370M15	37x1,5	28,9	35,1	1990	16
18070G7D050M25	5x2,5	13,5	17,8	560	16
18070G7D070M25	7x2,5	14,7	19,1	650	16
18070G7D120M25	12x2,5	19,8	24,7	970	16
18070G7D190M25	19x2,5	23,4	31,3	1360	14
18070G7D270M25	27x2,5	28,5	34,7	1990	14
18070G7D370M25	37x2,5	31,8	38,2	2480	14

Other dimensions and colors available on request.

GAALSHIP® G MEDIUM

SW4 or SW2 from 3,8/6 kV to 8,7/15 kV



ELETTROTEK KABEL® GAALSHIP® G MEDIUM

Construction:

Conductor:	stranded tinned copper conductor Cl. 2, acc to IEC 60228
Wrapping:	semiconducting tape on semiconducting layer
Insulation:	Halogen free EPR, type GP5 acc. to BS 7655 1-2
Screen:	semicoconducting layer and tinned copper tape
Cores color:	1x: natural color 3x: numbered tape
Inner sheath:	halogen free thermosetting type SW4, acc. to BS 7655 2.6, oil resistant
Armouring:	galvanized steel wires braid or tinned phosphorous bronze wire braid (single core)
Outer sheath:	red (RAL 3000), halogen free thermosetting type SW4 acc. to BS 7655 2.6, oil resistant

Technical data:

Nominal voltage:	3,8/6,6 8,7/15 kV
Temperature range:	- 40°C up to +90°C
Installation temp.:	- 20 °C
Short circuit temperature:	+250°C
Min. bending radius:	20 x d Single core 15 x d Three cores

Resistance:



Fire resistant acc. to:
IEC 60331- 21



Flame and fire retardant acc. to:
IEC 60332-1-2,
IEC 60332-3-22



Halogen free acc. to:
IEC 60754-1/2



Smoke emission properties acc. to:
IEC 61034-1/2

Features:

Sheathing materials acc. to: BS 7655 2.6
Insulating materials acc. to: BS 7655 1.2
Design guidelines acc. to: BS 6883:1999
Choice and installation of electric cables acc. to: IEC 60092-352 on request class 5
on request tinned copper wire braid armour
on request reduced halogen thermosetting type SW2 inner and outer sheath, acc. to BS 7655 2.6, oil and tear resistant

We have possibility to provide the following Certifications on request:

Bureau Veritas (BV)
Lloyd's Register (LR)
Registro Italiano Navale (RINA)
American Bureau of Shipping (ABS)



Available on stock CABLE GLANDS:
see page 404 up to 416 of catalogue.

GAALSHIP® OFFSHORE CABLES

GAALSHIP® G MEDIUM

SW4 or SW2 from 3,8/6 kV to 8,7/15 kV



3,8/6,6 kV

Part no.	No. of cores x cross section n x mm ²	Ø under armour ca. mm ± 10%	Outer-Ø ca. mm ± 10%	Cable weight approx. kg/km	AWG no. *)
19020MRL010M62	1x16	17	21,6	790	6
19020MRL010M63	1x25	18,7	23,4	950	4
19020MRL010M64	1x35	19,8	24,5	1060	2
19020MRL010M65	1x50	21,1	25,9	1320	1
19020MRL010M66	1x70	23,1	28	1610	2/0
19020MRL010M67	1x95	25	30	1930	3/0
19020MRL010M68	1x120	26,7	32	2260	4/0
19020MRL010M69	1x150	28,4	34,7	2760	250
19020MRL010MR0	1x185	30,6	33,5	3210	350
19020MRL010MR1	1x240	33,4	39,9	3960	450
19020MRL010MR2	1x300	35,6	42,8	4660	550
19020MRL010MR3	1x400	39,4	46,7	5470	750
19020MRL010MR4	1x500	43,4	51	6610	1000
19020MRD030M62	3x16	34,4	41,1	2610	6
19020MRD030M63	3x25	38	45,2	3220	4
19020MRD030M64	3x35	40,2	47	3700	2
19020MRD030M65	3x50	43,3	50,7	4360	1
19020MRD030M66	3x70	47,4	54,9	5410	2/0
19020MRD030M67	3x95	51,9	59,6	6710	3/0
19020MRD030M68	3x120	55,5	63,9	7770	4/0
19020MRD030M69	3x150	59	67,7	9160	250
19020MRD030MR0	3x185	63,5	72,5	10430	350

6,35/11 kV

Part no.	No. of cores x cross section n x mm ²	Ø under armour ca. mm ± 10%	Outer-Ø ca. mm ± 10%	Cable weight approx. kg/km	AWG no. *)
19020QRL010M62	1x16	17,8	22	810	6
19020QRL010M63	1x25	19,7	24,4	980	4
19020QRL010M64	1x35	20,7	25,5	1110	2
19020QRL010M65	1x50	22,1	26,8	1360	1
19020QRL010M66	1x70	23,9	28,8	1660	2/0
19020QRL010M67	1x95	25,8	31,1	1970	3/0
19020QRL010M68	1x120	27,7	34	2360	4/0
19020QRL010M69	1x150	29,2	35,7	2810	250
19020QRL010M70	1x185	31,4	37,7	3260	350
19020QRL010M71	1x240	34,2	41,6	4020	450
19020QRL010M72	1x300	36,7	43,8	4760	550
19020QRL010M73	1x400	40,2	47,4	5610	750
19020QRL010M74	1x500	43,8	51,4	6820	1000
19020QRD030M62	3x16	36,2	42,9	2660	6
19020QRD030M63	3x25	39,9	47	3310	4
19020QRD030M64	3x35	42,2	49,3	3960	2
19020QRD030M65	3x50	45	52,6	4570	1
19020QRD030M66	3x70	49,2	57,1	5610	2/0
19020QRD030M67	3x95	53,3	61,5	6820	3/0
19020QRD030M68	3x120	57,5	66	8070	4/0
19020QRD030M69	3x150	61	72,3	9260	250
19020QRD030M70	3x185	65,4	74,6	10960	350

Other dimensions and colors available on request.

GAALSHIP® OFFSHORE CABLES

GAALSHIP® G MEDIUM

SW4 or SW2 from 3,8/6 kV to 8,7/15 kV



8,7/15 kV

Part no.	No. of cores x cross section n x mm ²	Ø under armour ca.mm ± 10%	Outer-Ø ca.mm ± 10%	Cable weight approx. kg/km	AWG no.*)
19020SRL010M63	1x25	22,2	26,9	1150	4
19020SRL010M64	1x35	23	28	1260	2
19020SRL010M65	1x50	24,2	29,2	1510	1
19020SRL010M66	1x70	26,2	31,6	1770	2/0
19020SRL010M67	1x95	28,1	34,4	2270	3/0
19020SRL010M68	1x120	30	36,5	2730	4/0
19020SRL010M69	1x150	31,7	38,2	3020	250
19020SRL010M70	1x185	33,7	40,3	3490	350
19020SRL010M71	1x240	36,5	43,4	4260	450
19020SRL010M72	1x300	39,1	46,4	4810	550
19020SRL010M73	1x400	42,7	52,3	6160	750
19020SRL010M74	1x500	46,2	54,4	7330	1000
19020SRD030M63	3x25	45,1	52,7	3610	4
19020SRD030M64	3x35	47,2	55	4510	2
19020SRD030M65	3x50	50	58	5210	1
19020SRD030M66	3x70	54,4	62,8	6390	2/0
19020SRD030M67	3x95	58,3	66,9	7660	3/0
19020SRD030M68	3x120	62,4	71,6	8810	4/0
19020SRD030M69	3x150	66	75,3	10070	250
19020SRD030M70	3x185	70,4	80	11420	350

Other dimensions and colors available on request.

GAALSHIP® TI
SW4(i) F0 or SW2(i) 150/250 V



Construction:

Conductor:	stranded tinned copper conductor Cl. 2, acc to IEC 60228
Insulation:	Halogen free EPR, type GP4 acc. to BS 7655 1-2
Cores color:	pair: black - white triple: black - white - red quad: black - white - red - blue
Stranding:	cores lay-up in pairs, triples, laying-up of pairs, triples.
Screen:	individual screen, aluminium/polyester tape with tinned copper stranded drain wire and syntetic tape.
Outer sheath:	grey (RAL 7001) halogen free thermosetting type SW4, acc. to BS 7655 2.6, oil resistant.

Technical data:

Nominal voltage:	150/250 V
Temperature range:	- 40°C up to +90°C
Installation temp.:	- 20 °C
Short circuit temperature:	+250°C
Min. bending radius:	8 x d

Resistance:



Flame and fire retardant acc. to:
IEC 60332-1-2,
IEC 60332-3-22



Halogen free acc. to:
IEC 60754-1/2



Smoke emission properties acc. to:
IEC 61034-1/2

Features:

Sheathing materials acc. to: BS 7655 2.6
Insulating materials acc. to: BS 7655 1.2
Design guidelines acc. to: BS 6883:1999
Choice and installation of electric cables acc. to: IEC 60092-352 on request class 5
on request reduced halogen thermosetting type SW2 outer sheath, acc. to BS 7655 2.6, oil and tear resistant

We have possibility to provide the following Certifications on request:

Bureau Veritas (BV)
Lloyd's Register (LR)
Registro Italiano Navale (RINA)
American Bureau of Shipping (ABS)



Available on stock CABLE GLANDS:
see page 404 up to 416 of catalogue.

GAALSHIP® OFFSHORE CABLES

GAALSHIP® TI
SW4(i) F0 or SW2(i) I 50/250 V



Part no.	No. of pairs/triples/quads x cross section n x mm ²	Outer-Ø ca. mm ± 10%	Copper weight kg/km	Cable weight approx. kg/km	AWG no. *)
17010C5X012M07	1x2x0,75	8,1	18	95	19
17010C5X032M07	3x2x0,75	13,5	54	210	19
17010C5X072M07	7x2x0,75	18	126	380	19
17010C5X122M07	12x2x0,75	22,5	216	650	19
17010C5X202M07	20x2x0,75	27,9	360	1020	19
17010C5X272M07	27x2x0,75	32,3	486	1330	19
17010C5X372M07	37x2x0,75	37,6	667	1800	19
17010C5X012M10	1x2x1	8,6	23	105	18
17010C5X032M10	3x2x1	14,5	68	250	18
17010C5X072M10	7x2x1	19	126	480	18
17010C5X122M10	12x2x1	24,1	158	800	18
17010C5X202M10	20x2x1	30,2	360	1260	18
17010C5X272M10	27x2x1	34,4	450	1670	18
17010C5X372M10	37x2x1	40,4	833	2210	18
17010C5X013M07	1x3x0,75	8,5	25	105	19
17010C5X033M07	3x3x0,75	15,2	75	260	19
17010C5X073M07	7x3x0,75	20,9	174	500	19
17010C5X123M07	12x3x0,75	25,7	297	850	19
17010C5X013M10	1x3x1	9,2	32	130	18
17010C5X033M10	3x3x1	16,1	95	310	18
17010C5X073M10	7x3x1	22,2	221	630	18
17010C5X123M10	12x3x1	27,5	378	1050	18
17010C5X014M07	1x4x0,75	9,5	32	125	19
17010C5X034M07	3x4x0,75	17,4	95	320	19
17010C5X074M07	7x4x0,75	23,4	221	640	19
17010C5X014M10	1x4x1	10	41	150	18
17010C5X034M10	3x4x1	18,5	122	370	18
17010C5X074M10	7x4x1	24,9	284	760	18

Other dimensions and colors available on request.

GAALSHIP® TO SW4(c) or SW2(c) 150/250V



Construction:

Conductor:	stranded tinned copper conductor Cl. 2, acc to IEC 60228
Insulation:	Halogen free EPR, type GP4 acc. to BS 7655 1-2
Cores color:	pair: black - white triple: black - white - red quad: black - white - red - blue
Stranding:	cores lay-up in pairs, triples, laying-up of pairs, triples.
Screen:	overall screen, aluminium/polyester tape with tinned copper stranded drain wire and syntetic tape.
Outer sheath:	grey (RAL 7001) halogen free thermosetting type SW4, acc. to BS 7655 2.6, oil resistant.

Technical data:

Nominal voltage:	150/250 V
Temperature range:	- 40°C up to +90°C
<i>Installation temp.:</i>	- 20 °C
Short circuit temperature:	+250°C
Min. bending radius:	8 x d

Resistance:



Flame and fire retardant acc. to:
IEC 60332-1-2,
IEC 60332-3-22



Halogen free acc. to:
IEC 60754-1/2



Smoke emission properties acc. to:
IEC 61034-1/2

Features:

Sheathing materials acc. to: BS 7655 2.6
Insulating materials acc. to: BS 7655 1.2
Design guidelines acc. to: BS 6883:1999
Choice and installation of electric cables acc. to: IEC 60092-352 on request class 5
on request reduced halogen thermosetting type SW2 outer sheath, acc. to BS 7655 2.6, oil and tear resistant

We have possibility to provide the following Certifications on request:

Bureau Veritas (BV)
Lloyd's Register (LR)
Registro Italiano Navale (RINA)
American Bureau of Shipping (ABS)



Available on stock CABLE GLANDS:
see page 404 up to 416 of catalogue.

GAALSHIP® OFFSHORE CABLES

GAALSHIP® TO
SW4(c) or SW2(c) 150/250V



Part no.	No. of pairs/triples x cross section n x mm ²	Outer-Ø ca. mm ± 10%	Copper weight kg/km	Cable weight approx. kg/km	AWG no. *)
17030C5X032M07	3x2x0,75	13,5	45	175	19
17030C5X072M07	7x2x0,75	17,6	99	330	19
17030C5X122M07	12x2x0,75	22,9	167	530	19
17030C5X202M07	20x2x0,75	28,7	275	830	19
17030C5X272M07	27x2x0,75	32,6	369	1070	19
17030C5X372M07	37x2x0,75	36,1	504	1430	19
17030C5X032M10	3x2x1	14,3	59	185	18
17030C5X072M10	7x2x1	18,7	131	360	18
17030C5X122M10	12x2x1	24,4	221	590	18
17030C5X202M10	20x2x1	30	365	920	18
17030C5X272M10	27x2x1	35	491	1220	18
17030C5X372M10	37x2x1	38,6	671	1630	18
17030C5X033M07	3x3x0,75	15,2	66	230	19
17030C5X073M07	7x3x0,75	20,6	147	440	19
17030C5X123M07	12x3x0,75	25,5	248	730	19
17030C5X033M10	3x3x1	16,1	86	260	19
17030C5X073M10	7x3x1	22,1	194	510	18
17030C5X123M10	12x3x1	27,1	329	840	18

Other dimensions and colors available on request.

GAALSHIP® TIG (RFCU(i) 250 V)

SW4(i) or SW2(i) 150/250V



Construction:

Conductor:	stranded tinned copper conductor Cl. 2, acc to IEC 60228
Insulation:	Halogen free EPR, type GP4 acc. to BS 7655 1-2
Cores color:	pair: black - white triple: black - white - red quad: black - white - red - blue
Stranding:	cores lay-up in pairs, triples, laying-up of pairs, triples.
Screen:	Individual screen, aluminium/polyester tape with tinned copper stranded drain wire and syntetic tape.
Inner sheath:	Halogen free thermosetting type SW4, acc. to BS 7655 2.6, oil resistant
Armouring:	galvanized steel wires braid
Outer sheath:	grey (RAL 7001) halogen free thermosetting type SW4, acc. to BS 7655 2.6, oil resistant.

Technical data:

Nominal voltage:	150/250 V
Temperature range:	- 40°C up to +90°C
<i>Installation temp.:</i>	- 20 °C
Short circuit temperature:	+250°C
Min. bending radius:	8 x d

Resistance:



Flame and fire retardant acc. to:
IEC 60332-1-2,
IEC 60332-3-22



Halogen free acc. to:
IEC 60754-1/2



Smoke emission properties acc. to:
IEC 61034-1/2

Features:

Sheathing materials acc. to: BS 7655 2.6
Insulating materials acc. to: BS 7655 1.2
Design guidelines acc. to: BS 6883:1999
Choice and installation of electric cables acc. to: IEC 60092-352 on request class 5
on request reduced halogen thermosetting type SW2 inner sheath, acc. to BS 7655 2.6, oil and tear resistant
on request tinned copper wire braid armour
on request reduced halogen thermosetting type SW2 outer sheath, acc. to BS 7655 2.6, oil and tear resistant

We have possibility to provide the following Certifications on request:

Bureau Veritas (BV)
Lloyd's Register (LR)
Registro Italiano Navale (RINA)
American Bureau of Shipping (ABS)



Available on stock CABLE GLANDS:
see page 404 up to 416 of catalogue.

GAALSHIP® OFFSHORE CABLES

GAALSHIP® TIG (RFCU(i) 250 V) SW4(i) or SW2(i) 150/250 V



Part no.	No. of pairs/triples/quads x cross section n x mm ²	Ø under armour ca. mm ± 10%	Outer-Ø ca. mm ± 10%	Cable weight approx. kg/km	AWG no. *)
17050C5X012M07	1x2x0,75	8,2	12	250	19
17050C5X032M07	3x2x0,75	13,6	17,9	440	19
17050C5X072M07	7x2x0,75	18	22,9	730	19
17050C5X122M07	12x2x0,75	22,5	27,7	1090	19
17050C5X202M07	20x2x0,75	28,4	35,1	1750	19
17050C5X272M07	27x2x0,75	32,4	39,3	2190	19
17050C5X372M07	37x2x0,75	37,6	45,2	2780	19
17050C5X012M10	1x2x1	8,6	12,5	260	18
17050C5X032M10	3x2x1	14,5	18,8	490	18
17050C5X072M10	7x2x1	19,1	24	810	18
17050C5X122M10	12x2x1	24,1	30,1	1370	18
17050C5X202M10	20x2x1	30,2	37,1	2010	18
17050C5X272M10	27x2x1	34,3	41,8	2570	18
17050C5X372M10	37x2x1	40,4	48,1	3290	18
17050C5X013M07	1x3x0.75	8,6	12,5	270	19
17050C5X033M07	3x3x0.75	15,2	19,8	540	19
17050C5X073M07	7x3x0.75	20,9	26	910	19
17050C5X123M07	12x3x0.75	25,6	32,3	1500	19
17050C5X013M10	1x3x1	9,3	13	290	18
17050C5X033M10	3x3x1	16,1	20,9	600	18
17050C5X073M10	7x3x1	22,3	27,2	1030	18
17050C5X123M10	12x3x1	27,6	34	1740	18
17050C5X014M07	1x4x0,75	9,5	13,4	290	19
17050C5X034M07	3x4x0,75	17,5	22,4	610	19
17050C5X074M07	7x4x0,75	23,5	28,5	1060	19
17050C5X014M10	1x4x1	10	13,9	330	18
17050C5X034M10	3x4x1	18,6	23,5	680	18
17050C5X074M10	7x4x1	24,9	30,7	1290	18

Other dimensions and colors available on request.

GAALSHIP® TOG (RFCU(c) 250 V) SW4(c) or SW2(c) 150/250 V



Construction:

Conductor:	stranded tinned copper conductor Cl. 2, acc to IEC 60228
Insulation:	Halogen free EPR, type GP4 acc. to BS 7655 1-2
Cores color:	pair: black - white triple: black - white - red quad: black - white - red - blue
Stranding:	cores lay-up in pairs, triples, laying-up of pairs, triples.
Screen:	overall screen, aluminium/polyester tape with tinned copper stranded drain wire and syntetic tape.
Inner sheath:	Halogen free thermosetting type SW4, acc. to BS 7655 2.6, oil resistant
Armouring:	galvanized steel wires braid
Outer sheath:	grey (RAL 7001) halogen free thermosetting type SW4, acc. to BS 7655 2.6, oil resistant.

Technical data:

Nominal voltage:	150/250 V
Temperature range:	- 40°C up to +90°C
Installation temp.:	- 20 °C
Short circuit temperature:	+250°C
Min. bending radius:	8 x d

Resistance:



Flame and fire retardant acc. to:
IEC 60332-1-2,
IEC 60332-3-22



Halogen free acc. to:
IEC 60754-1/2



Smoke emission properties acc. to:
IEC 61034-1/2

Features:

Sheathing materials acc. to: BS 7655 2.6
Insulating materials acc. to: BS 7655 1.2
Design guidelines acc. to: BS 6883:1999
Choice and installation of electric cables acc. to: IEC 60092-352 on request class 5
on request reduced halogen thermosetting type SW2 inner sheath, acc. to BS 7655 2.6, oil and tear resistant
on request tinned copper wire braid armour
on request reduced halogen thermosetting type SW2 outer sheath, acc. to BS 7655 2.6, oil and tear resistant

We have possibility to provide the following Certifications on request:

Bureau Veritas (BV)
Lloyd's Register (LR)
Registro Italiano Navale (RINA)
American Bureau of Shipping (ABS)



Available on stock CABLE GLANDS: see page 404 up to 416 of catalogue.

GAALSHIP® OFFSHORE CABLES

GAALSHIP® TOG (RFCU(c) 250 V) SW4(c) or SW2(c) 150/250 V



Part no.	No. of pairs/triples x cross section n x mm ²	Ø under armour ca. mm ± 10%	Outer-Ø ca. mm ± 10%	Cable weight approx. kg/km	AWG no. *)
17070C5X032M07	3x2x0,75	13,6	17,9	390	19
17070C5X072M07	7x2x0,75	17,7	22	620	19
17070C5X122M07	12x2x0,75	23	28	930	19
17070C5X202M07	20x2x0,75	28,7	35,2	1460	19
17070C5X272M07	27x2x0,75	32,7	39,4	1810	19
17070C5X372M07	37x2x0,75	36,1	43,3	2270	19
17070C5X032M10	3x2x1	14,3	18,6	410	18
17070C5X072M10	7x2x1	18,7	23,6	680	18
17070C5X122M10	12x2x1	24,5	29,6	1010	18
17070C5X202M10	20x2x1	30,5	37,3	1600	18
17070C5X272M10	27x2x1	35	42,2	2000	18
17070C5X372M10	37x2x1	38,6	46,3	2540	18
17070C5X033M07	3x3x0,75	15,2	19,6	480	19
17070C5X073M07	7x3x0,75	20,7	25,5	780	19
17070C5X123M07	12x3x0,75	25,5	31,1	1320	19
17070C5X033M10	3x3x1	16,1	21	530	19
17070C5X073M10	7x3x1	22,3	27,2	890	18
17070C5X123M10	12x3x1	27,2	33,6	1480	18

Other dimensions and colors available on request.

GAALSHIP® TIG FR (BFCU(i) 250 V) SW4 FO(i)/FI or SW2 FO(i)/FI 150/250 V



Construction:

Conductor:	stranded tinned copper conductor Cl. 2, acc to IEC 60228
Insulation:	Halogen free EPR, type GP4 acc. to BS 7655 1-2 + MICA glass tape
Cores color:	pair: black - white triple: black - white - red quad: black - white - red - blue
Stranding:	cores lay-up in pairs, triples, laying-up of pairs, triples.
Screen:	individual screen, aluminium/polyester tape with tinned copper stranded drain wire and syntetic tape.
Inner sheath:	halogen free thermosetting type SB1, acc. to BS 7917, thickness acc. to BS 7917
Armouring:	galvanized steel wires braid
Outer sheath:	grey (RAL 7001) halogen free thermosetting type SW4, acc. to BS 7655 2.6, oil resistant.

Technical data:

Nominal voltage:	150/250 V
Temperature range:	- 40°C up to +90°C
<i>Installation temp.:</i>	- 20 °C
Short circuit temperature:	+250°C
Min. bending radius:	8 x d

Resistance:



Fire resistant acc. to:
IEC 60331- 21



Flame and fire retardant acc. to:
IEC 60332-1-2,
IEC 60332-3-22



Halogen free acc. to:
IEC 60754-1/2



Smoke emission properties acc. to:
IEC 61034-1/2

Features:

Sheathing materials acc. to: BS 7655 2.6
Insulating materials acc. to: BS 7655 1.2
Design guidelines acc. to: BS 7917:1999
Choice and installation of electric cables acc. to: IEC 60092-352 on request class 5
on request tinned copper wire braid armour
on request reduced halogen thermosetting type SW2 outer sheath, acc. to BS 7655 2.6, oil and tear resistant

We have possibility to provide the following Certifications on request:

Bureau Veritas (BV)
Lloyd's Register (LR)
Registro Italiano Navale (RINA)
American Bureau of Shipping (ABS)



Available on stock CABLE GLANDS:
see page 404 up to 416 of catalogue.

GAALSHIP® OFFSHORE CABLES

GAALSHIP® TIG FR (BFCU(i) 250 V) SW4 FO(i)/FI or SW2 FO(i)/FI 150/250 V



ELETTROTEK KABEL® GAALSHIP® TIG FR (BFCU(i) 250 V)

Part no.	No. of pairs/triples x cross section n x mm ²	Ø under armour ca. mm ± 10%	Outer-Ø ca. mm ± 10%	Cable weight approx. kg/km	AWG no. *)
17090C5X012M07	1x2x0,75	9	12,8	270	19
17090C5X032M07	3x2x0,75	15	19,3	500	19
17090C5X072M07	7x2x0,75	20,1	25	840	19
17090C5X122M07	12x2x0,75	25,2	30	1280	19
17090C5X202M07	20x2x0,75	32	38,5	2050	19
17090C5X272M07	27x2x0,75	36,4	43,5	2580	19
17090C5X372M07	37x2x0,75	42,5	50	3290	19
17090C5X012M10	1x2x1	9,4	13,2	280	18
17090C5X032M10	3x2x1	16	20,3	540	18
17090C5X072M10	7x2x1	21,3	26,1	900	18
17090C5X122M10	12x2x1	26,7	33	1520	18
17090C5X202M10	20x2x1	33,7	41	2250	18
17090C5X272M10	27x2x1	38,5	46	2860	18
17090C5X372M10	37x2x1	45	52,9	3670	18
17090C5X013M07	1x3x0,75	9,5	12,8	280	19
17090C5X033M07	3x3x0,75	16	20,7	580	19
17090C5X073M07	7x3x0,75	22,1	27	960	19
17090C5X123M07	12x3x0,75	13,6	33,7	1590	19
17090C5X013M10	1x3x1	9,6	13,4	300	18
17090C5X033M10	3x3x1	16,8	21,5	620	18
17090C5X073M10	7x3x1	23,2	28,2	1050	18
17090C5X123M10	12x3x1	28,9	35,4	1760	18
17090C5X014M07	1x4x0,75	10	13,8	330	19
17090C5X034M07	3x4x0,75	18,5	23,3	720	19
17090C5X074M07	7x4x0,75	24,8	30	1240	19
17090C5X014M10	1x4x1	10,5	14,3	350	18
17090C5X034M10	3x4x1	19,5	24,5	780	18
17090C5X074M10	7x4x1	26,3	32,5	1470	18

Other dimensions and colors available on request.

GAALSHIP® TOG FR (BFCU(c) 250 V)

SW4 FO(c)/FI or SW2 FO(c)/FI 150/250 V



Construction:

Conductor:	stranded tinned copper conductor Cl. 2, acc to IEC 60228
Insulation:	Halogen free EPR, type GP4 acc. to BS 7655 1-2 + MICA glass tape
Cores color:	pair: black - white triple: black - white - red quad: black - white - red - blue
Stranding:	cores lay-up in pairs, triples, laying-up of pairs, triples.
Screen:	overall screen, aluminium/polyester tape with tinned copper stranded drain wire and syntetic tape.
Inner sheath:	halogen free thermosetting type SB1, acc. to BS 7917, thickness acc. to BS 7917
Armouring:	galvanized steel wires braid
Outer sheath:	grey (RAL 7001) halogen free thermosetting type SW4, acc. to BS 7655 2.6, oil resistant.

Technical data:

Nominal voltage:	150/250 V
Temperature range:	- 40°C up to +90°C
Installation temp.:	- 20 °C
Short circuit temperature:	+250°C
Min. bending radius:	8 x d

Resistance:



Fire resistant acc. to:
IEC 60331- 21



Flame and fire retardant acc. to:
IEC 60332-1-2,
IEC 60332-3-22



Halogen free acc. to:
IEC 60754-1/2



Smoke emission properties acc. to:
IEC 61034-1/2

Features:

Sheathing materials acc. to: BS 7655 2.6
Insulating materials acc. to: BS 7655 1.2
Design guidelines acc. to: BS 7917:1999
Choice and installation of electric cables acc. to: IEC 60092-352
on request class 5
on request tinned copper wire braid armour
on request reduced halogen thermosetting type SW2 outer sheath, acc. to BS 7655 2.6, oil and tear resistant

We have possibility to provide the following Certifications on request:

Bureau Veritas (BV)
Lloyd's Register (LR)
Registro Italiano Navale (RINA)
American Bureau of Shipping (ABS)



Available on stock CABLE GLANDS:
see page 404 up to 416 of catalogue.

GAALSHIP® OFFSHORE CABLES

GAALSHIP® TOG FR (BFCU(c) 250 V) SW4 FO(c)/FI or SW2 FO(c)/FI 150/250 V



Part no.	No. of pairs/triples x cross section n x mm ²	Ø under armour ca. mm ± 10%	Outer-Ø ca. mm ± 10%	Cable weight approx. kg/km	AWG no. *)
17110C5X032M07	3x2x0,75	15	19,3	450	19
17110C5X072M07	7x2x0,75	19,7	24,3	720	19
17110C5X122M07	12x2x0,75	25,7	31	1080	19
17110C5X202M07	20x2x0,75	32,6	38,8	1370	19
17110C5X272M07	27x2x0,75	36,8	43,7	2140	19
17110C5X372M07	37x2x0,75	40,7	47,8	2710	19
17110C5X032M07	3x2x0,75	15	19,3	450	19
17110C5X072M07	7x2x0,75	19,7	24,3	720	19
17110C5X122M07	12x2x0,75	25,7	31	1080	19
17110C5X202M07	20x2x0,75	32,6	38,8	1370	19
17110C5X272M07	27x2x0,75	36,8	43,7	2140	19
17110C5X372M07	37x2x0,75	40,7	47,8	2710	19
17110C5X032M10	3x2x1	15,8	20,1	460	18
17110C5X072M10	7x2x1	20,8	25,6	780	18
17110C5X122M10	12x2x1	27,2	32,6	1170	18
17110C5X202M10	20x2x1	34,2	41	1860	18
17110C5X272M10	27x2x1	39,1	46	2330	18
17110C5X372M10	37x2x1	43,3	50,7	2980	18
17110C5X072M15	7x2x1,5	23,6	25,5	860	16
17110C5X033M07	3x3x0,75	16	20,3	510	19
17110C5X073M07	7x3x0,75	21,8	26,6	810	19
17110C5X123M07	12x3x0,75	27	33,3	1370	19
17110C5X033M10	3x3x1	16,8	21,5	550	19
17110C5X073M10	7x3x1	23,2	28,2	910	18
17110C5X123M10	12x3x1	28,5	35	1510	18

Other dimensions and colors available on request.



“IEC” Normatives

“IEC” normatives

GAALSHIP® OFFSHORE cables according to:

IEC 60092-350:	General construction and test requirement.
IEC 60092-351:	Insulating materials for shipboard power cables.
IEC 60092-352:	Choice and installation of electric cables.
IEC 60092-353:	Single and multicore cables with extruded solid insulation for rated voltages 0.6/1 and 1.8/3 kV.
IEC 60092-354:	Single and three-core power cables with extruded solid insulation for rated voltages 6 and 30 kV.
IEC 60092-359:	Sheating materials for shipboard power cables.
IEC 60228:	Conductors of insulated cables.
IEC 60331 :	Fire resisting characteristics of electrical cables.
IEC 60332-1-2:	Test on a single vertical insulated wire or cable.
IEC 60332-3-22:	Test on bunched wires or cables.
IEC 60754-1/60754-2:	Test on gases evolved during combustion of materials from cable.
IEC 60811:	Common test methods for insulating and sheating materials of electric cables.
IEC 61034-1/61034-2:	Measurements of smoke density of electric cable burning under defined conditions.

Legend

(IEC 60092-353 and IEC 60092-376)

Cable element	Code
Conductor (CL.2 or CL.5)	R or F
Mica tape(s) for fire resistant cables	T
Insulation: cross linked polyethylene (XLPE)	E4
Units (pairs/triples/quads)	X
Round cable (cores or units)	O
Screen (laminated tape(s)+drain wire)	H
Braid armour	A
Halogen free thermoplastic compound SHF1	M1

Cores identification

Insulation colour scheme:

0,6/1 kV Power and control cables

According to standard HD 308 S2

Insulated cores with Green/Yellow

2 cores	-	-			
3 cores	Green / Yellow	Blue	Brown		
4 cores	Green / Yellow	-	Brown	Black	Grey
5 cores	Green / Yellow	Blue	Brown	Black	Grey
above 5 cores	Green / Yellow	Black numbers on white base			

Insulated cores with Green/Yellow

2 cores	Blue	Brown			
3 cores	-	Brown	Black	Grey	
4 cores	Blue	Brown	Black	Grey	
5 cores	Blue	Brown	Black	Grey	Black
above 5 cores	Black numbers on white base				

150/250 V Instrumentation cables

N. of cores	Cores colour
Pair	Black - Light Blue
Triple	Black - Light Blue - Brown

Pairs/Triples/Quads are numbered with numbers printed directly on the insulated conductors (1-1; 2-2; ...) or buy numbered tape

Other colours available on request

Outer sheath colours (STANDARDS COLOURS)

Instrumentation and control	GREY
Power LV	BLACK
Other colours available on request	

GAALSHIP® LD

RE4(O)A(CuSn)M1 or FE4(O)A(CuSn)M1 0,6/1 kV



ELETTROTEK KABEL® GAALSHIP® LD
RE4(O)A(CuSn)M1 or FE4(O)A(CuSn)M1 0,6/1 kV



Construction:

- Conductor:** stranded tinned copper conductor Cl. 2, acc to IEC 60228
- Insulation:** XLPE, Halogen free compound acc. to IEC 60092-351, thickness acc. to IEC60092-353
- Cores color:** acc. to HD 308 S2
- Inner sheath:** halogen free thermoplastic compound, indicative thickness acc. to IEC 60092-353
- Armouring:** tinned copper wires braid acc. to IEC 60092-350, IEC 60092-352 used as earth conductor
- Outer sheath:** black (RAL 9005) halogen free thermoplastic compound SHF1 acc. to IEC 60092-359, thickness acc. to IEC 60092-353

Resistance:



Flame and fire retardant acc. to:
IEC 60332-1-2,
IEC 60332-3-22



Halogen free acc. to:
IEC 60754-1



Smoke emission properties acc. to:
IEC 61034-2

Technical data:

- Nominal voltage:** 0,6/1 kV
- Temperature range:** - 25°C up to +90°C
- Installation temp.:** - 5°C
- Short circuit temperature:** +250°C
- Min. bending radius:** 6 x D

Features:

- Sheathing materials acc. to: IEC 60092-359
- Insulating materials acc. to: IEC 60092-351
- Design guidelines acc. to: IEC 60092-353 / IEC 60092-350
- Choice and installation of electric cables acc. to: IEC 60092-352 on request class 5



Available on stock CABLE GLANDS:
see page 404 up to 416 of catalogue.

Part no.	No. of cores x cross section n x mm ²	Ø under armour ca. mm ± 10%	Outer-Ø ca. mm ± 10%	Cable weight approx. kg/km	AWG no. *)
21010G73030M15	3x1,5	8,9	12,2	240	16
21010G73030M25	3x2,5	9,7	13	290	14
21010G73030M40	3x4	10,8	14	350	12
21010G73030M60	3x6	12,2	16	470	10
21010G73030M61	3x10	14,1	18,5	650	8
21010G73030M62	3x16	16,4	20,5	900	6
21010G73030M63	3x25	20,3	25	1295	4
21010G73030M64	3x35	23,2	28	1805	2
21010G73030M65	3x50	26,5	32	2440	1
21010G73030M66	3x70	30,3	36,5	3265	2/0
21010G73030M67	3x95	34,2	41	4095	3/0
21010G73030M68	3x120	38,1	45,5	5275	4/0
21010G73030M69	3x150	42,2	49,5	6525	250 MCM
21010G73030M70	3x185	47,9	56	7735	350 MCM
21010G73030M71	3x240	53,9	62	9715	450 MCM

Other dimensions and colors available on request.

GAALSHIP® LD

RE4XOHM1A(CuSn)M1 or FE4XOHM1A(CuSn)M1 150/250 V



ELETTROTEK KABEL® GAALSHIP® LD
RE4XOHM1A(CuSn)M1 or FE4XOHM1A(CuSn)M1 150/250 V

Construction:

- Conductor:** stranded tinned copper conductor Cl. 2, acc to IEC 60228
- Insulation:** XLPE, Halogen free compound acc. to IEC 60092-351, thickness acc. to IEC60092-353
- Cores color:** pair: black- light blue
triple: black- light blue-brown
- Screen:** overall screen, copper/polyester tape with tinned copper stranded drain wire and syntetic tape.
- Inner sheath:** halogen free compound
Indicative thickness
acc. to IEC 60092-376
- Armouring:** tinned copper wires braid acc. to IEC 60092-350, IEC 60092-352 used as earth conductor
- Outer sheath:** grey (RAL 7001), halogen free thermosetting compound SHF1, acc. to IEC 60092-359 thickness acc. to IEC 60092-376

Technical data:

- Nominal voltage:** 150/250 V
- Temperature range:** - 25°C up to +90°C
- Installation temp.:** - 5°C
- Short circuit temperature:** +250°C
- Min. bending radius:** 8 x D

Resistance:



Flame and fire retardant acc. to:
IEC 60332-1-2,
IEC 60332-3-22



Halogen free acc. to:
IEC 60754-1/2



Smoke emission properties acc. to:
IEC 61034-1/2

Features:

- Sheathing materials acc. to: IEC 60092-359
- Insulating materials acc. to: IEC 60092-351
- Design guidelines acc. to: IEC 60092-376 / IEC 60092-350
- Choice and installation of electric cables acc. to: IEC 60092-352 on request class 5



Available on stock CABLE GLANDS:
see page 404 up to 416 of catalogue.

Part no.	No. of cores x cross section n x mm ²	Ø under armour ca.mm ± 10%	Outer-Ø ca.mm ± 10%	Cable weight approx. kg/km	AWG no.®)
20010C5X022M07	2x2x0,75	11,7	15	340	19
20010C5X032M07	3x2x0,75	12,3	15,6	365	19
20010C5X042M07	4x2x0,75	13,7	17,4	475	19
20010C5X072M07	7x2x0,75	16,2	20,1	595	19
20010C5X122M07	12x2x0,75	19,9	24	820	19
20010C5X162M07	16x2x0,75	22,4	26,5	975	19
20010C5X192M07	19x2x0,75	24,5	28,6	1125	19
20010C5X242M07	24x2x0,75	27,1	31,4	1330	19
20010C5X272M07	27x2x0,75	28	32,8	1430	19
20010C5X322M07	32x2x0,75	31,7	36,2	1685	19
20010C5X022M15	2x2x1,5	13,8	17,5	510	16
20010C5X032M15	3x2x1,5	14,4	18,1	530	16
20010C5X042M15	4x2x1,5	16	19,9	620	16
20010C5X072M15	7x2x1,5	19,4	23,3	830	16
20010C5X122M15	12x2x1,5	23,8	28,1	1185	16
20010C5X162M15	16x2x1,5	26,9	31,2	1550	16
20010C5X192M15	19x2x1,5	29,3	33,8	1675	16
20010C5X242M15	24x2x1,5	32,5	37,6	2095	16
20010C5X272M15	27x2x1,5	34,6	39,7	2345	16
20010C5X322M15	32x2x1,5	38	43,3	2680	16

Other dimensions and colors available on request.

Max. DC resistance at 20°C acc. to IEC 60228

Tinned conductors

Cross-section x mm ²	Cl. 2 Ohm/km	Cl. 5 Ohm/km	Cross section mm ²	Cl. 2 Ohm/km	Cl. 5 Ohm/km
1	18,2	20,0	70	0,270	0,277
1,5	12,2	13,7	95	0,195	0,210
2,5	7,56	8,21	120	0,154	0,164
4	4,70	5,09	150	0,126	0,132
6	3,11	3,39	185	0,100	0,108
10	1,84	1,95	240	0,0762	0,0817
16	1,16	1,24	300	0,0607	0,0654
25	0,734	0,795	400	0,0475	0,0495
35	0,529	0,565	500	0,0396	0,0391
50	0,391	0,393	630	0,0286	0,0292

Plain conductor

Cross-section x mm ²	Cl. 2 Ohm/km	Cl. 5 Ohm/km	Cross section mm ²	Cl. 2 Ohm/km	Cl. 5 Ohm/km
1	18,1	19,5	70	0,268	0,272
1,5	12,1	13,3	95	0,193	0,206
2,5	7,41	7,98	120	0,153	0,161
4	4,61	4,95	150	0,124	0,129
6	3,08	3,30	185	0,0991	0,106
10	1,83	1,91	240	0,0754	0,0801
16	1,15	1,21	300	0,0601	0,0641
25	0,727	0,780	400	0,0470	0,0486
35	0,524	0,554	500	0,0366	0,0384
50	0,387	0,387	630	0,0283	0,0287

Derating factors

for various ambient air temperature acc. to IEC 60092-352

Temp.	35°	40°	45°	50°	55°	60°	65°	70°	75°	80°
cf.	1,10	1,05	1,00	0,94	0,88	0,82	0,74	0,67	0,58	0,47

Short circuit current

starting temperature 90°C, final temperature 250°C

Cross-section x mm ²	I sec. A	0,5 sec. A	0,2 sec. A	Cross-section x mm ²	I sec. A	0,5 sec. A	0,2 sec. A
1	143	202	320	70	10010	14156	22383
1,5	215	303	480	95	13585	19212	30377
2,5	358	506	799	120	17160	24268	38371
4	572	809	1279	150	21450	30335	47964
6	858	1213	1919	185	26455	37413	59155
10	1430	2022	3198	240	34320	48536	76742
16	2288	3236	5116	300	42900	60670	95927
25	3575	5056	7994	400	57200	80893	127903
35	5005	7078	11192	500	71500	101116	159879
50	7150	10112	15988	600	90090	127406	201447

Voltage drop (Cables up to 1 kV)

cross-section x mm ²	3x1 cores (trefoil formation)		2 cores		3-4 cores	
	C.d.T. c.a. Cosfi I mV/Am	C.d.T. c.a. Codfi 0,8 mV/Am	C.d.T. c.a. Cosfi I mV/Am	C.d.T. c.a. Codfi 0,8 mV/Am	C.d.T. c.a. Cosfi I mV/Am	C.d.T. c.a. Codfi 0,8 mV/Am
1			46,4	37,3	40,1	32,3
1,5			31,1	25,0	26,9	21,7
2,5			19,3	15,6	16,7	13,5
4			12,0	9,73	10,4	8,41
6			7,93	6,48	6,86	5,6
10	3,51	2,90	4,69	2,9	4,69	3,88
16	2,21	1,86	2,96	1,86	2,96	2,48
25	1,40	1,21	1,87	1,21	1,87	1,61
35	1,01	0,891	1,35	0,891	1,35	1,19
50	0,747	0,681	0,998	0,681	0,998	0,91
70	0,517	0,494	0,690	0,494	0,69	0,66
95	0,374	0,379	0,500	0,379	0,5	0,507
120	0,296	0,316	0,396	0,316	0,396	0,422
150	0,244			0,273	0,282	0,316
185	0,195			0,234	0,225	0,271
240	0,151			0,198	0,174	0,229
300	0,122			0,175	0,142	0,203

Instrumentation cables

Max DC resistance 20°C acc. To IEC 60092-376

cross-section x mm ²	Tinned conductor		Plain conductor	
	cl. 2 Ohm/km	cl. 5 Ohm/km	cl. 2 Ohm/km	cl. 5 Ohm/km
0,75	26,3	28,3	26	27,6
1	19,3	21,2	19,2	20,7
1,5	12,9	14,5	12,8	14,1
2,5	8,02	8,71	7,56	8,47





“IEEE” Normatives

GAALSHIP® POWER IEEE type P SC

Extremely flexible, 110°C, 600 V single-core, unarmoured

ELETTROTEK KABEL® GAALSHIP® POWER IEEE type P SC

Construction:

Conductor: flexible tinned copper conductor, acc to IEEE 1580 table 11

Insulation: special cross-linked polyolefin acc. to IEEE type P, and UL 1309/CSA 245 type X110 2000 V/ IEC 1000 V

Technical data:

Nominal voltage: 600 V

Temperature range: - 40°C up to + 110°C

Resistance:



Fire retardant acc. to:
IEC 60332-3-22,
IEEE 1202

Features:

Oil abrasion, chemical, moisture, cold resistant

Sunlight resistant

low toxic and corrosive gases emissions

highest ampacity ratings:
ABS 100°C, DNV 95°C, Transport Canada 95°C

NVE 95/16996, FAL

Transport Canada

Det Norske Veritas (DNV)

Lloyd's register of shipping (LRS)

American Bureau of Shipping (ABS)

UL listed as Marine Shipboard Cables

United States Coast Guard November 2, 1987

CSA listed as Marine shipboard cables



on request 2 kV version:
unarmoured, armoured (B),
armoured and sheathed



Available on stock CABLE GLANDS:
see page 404 up to 416 of catalogue.

Part no.	No. of cores x cross section n x AWG/MCM	Outer-Ø ca. inches ± 10%	Cable weight approx. lbs/MFt.
24010F7L010A18	1 x 18	0,143	16
24010F7L010A16	1 x 16	0,153	18
24010F7L010A14	1 x 14	0,168	25
24010F7L010A12	1 x 12	0,187	32
24010F7L010A10	1 x 10	0,207	51
24010F7L010A08	1 x 8	0,255	71
24010F7L010A06	1 x 6	0,295	108
24010F7L010A04	1 x 4	0,377	173
24010F7L010A02	1 x 2	0,443	242
24010F7L010A01	1 x 1	0,484	335
24010F7L010A1C	1 x 1/0	0,548	420
24010F7L010A2C	1 x 2/0	0,615	494
24010F7L010A3C	1 x 3/0	0,663	734

* Unarmoured up to 3/0 has a Insulation acc. to UL 1309 & IEEE 1580

Other dimensions and colors available on request.

GAALSHIP® POWER IEEE type P

Extremely flexible, 110°C, 0,6/1 kV multi-core, unarmoured

ELETTROTEK KABEL® GAALSHIP® POWER IEEE type P



Construction:

Conductor:	flexible tinned copper conductor, acc to IEEE 1580 table 11
Insulation:	special cross-linked polyolefin acc. to IEEE type P, and UL 1309/CSA 245 type X110
Cores color:	
<i>two-conductors:</i>	black-white
<i>three-conductors:</i>	black-white-red
<i>four-conductors:</i>	black-white-red-green
<i>five-conductors:</i>	black-white-red-green-orange
Outer sheath:	black (RAL 9005), thermosetting compound acc. to UL 1309/CSA 245 and IEEE 1580

Technical data:

Nominal voltage:	0,6/1 kV
Temperature range:	- 40°C up to + 110°C

Resistance:



Fire retardant acc. to:
IEC 60332-3-22,
IEEE 1202

Features:

Oil abrasion, chemical, moisture, cold resistant
Sunlight resistant
low toxic and corrosive gases emissions
highest ampacity ratings:
ABS 100°C, DNV 95°C, Transport Canada 95°C
NVE 95/16996, FAL
Transport Canada
Det Norske Veritas (DNV)
Lloyd's register of shipping (LRS)
American Bureau of Shipping (ABS)
UL listed as Marine Shipboard Cables
United States Coast Guard November 2, 1987
CSA listed as Marine shipboard cables



Available on stock CABLE GLANDS:
see page 404 up to 416 of catalogue.

GAALSHIP® OFFSHORE CABLES

GAALSHIP® POWER IEEE type P

Extremely flexible, 110°C, 600V multi-core, unarmoured

ELETTROTEK KABEL® GAALSHIP® POWER IEEE type P



Part no.	No. of cores x cross section n x AWG/MCM	Outer-Ø ca. inches ± 10%	Cable weight approx. lbs/Mft.
24020G7K020A16	2 x 16	0,35	75
24020G7K020A14	2 x 14	0,38	84
24020G7K020A12	2 x 12	0,42	111
24020G7K020A10	2 x 10	0,46	146
24020G7K020A08	2 x 8	0,6	221
24020G7K020A06	2 x 6	0,68	308
24020G7K020A04	2 x 4	0,887	516
24020G7K020A1C	2 x 1/0	1,243	1128
24020G7K020A4C	2 x 4/0	1,593	2003
24020G7K030A16	3 x 16	0,369	65
24020G7K030A14	3 x 14	0,401	102
24020G7K030A12	3 x 12	0,445	133
24020G7K030A10	3 x 10	0,488	189
24020G7K030A08	3 x 8	0,637	274
24020G7K030A06	3 x 6	0,732	390
24020G7K030A04	3 x 4	0,942	678
24020G7K030A02	3 x 2	1,084	987
24020G7K030A01	3 x 1	1,206	1234
24020G7K030A1C	3 x 1/0	1,326	1448
24020G7K030A2C	3 x 2/0	1,422	1945
24020G7K030A3C	3 x 3/0	1,528	2379
24020G7K030A4C	3 x 4/0	1,765	2864
24020G7K030APC	3 x 262	1,98	3452
24020G7K030AQC	3 x 313	2,131	4023
24020G7K030ANC	3 x 373	2,231	4772
24020G7K030ARC	3 x 444	2,394	5670
24020G7K030AOC	3 x 535	2,637	6784
24020G7K030ASC	3 x 646	2,958	7961
24020G7K030ATC	3 x 777	3,168	9573
24020G7K040A16	4 x 16	0,402	99
24020G7K040A14	4 x 14	0,438	126
24020G7K040A12	4 x 12	0,486	168
24020G7K040A10	4 x 10	0,553	243
24020G7K040A08	4 x 8	0,698	355
24020G7K040A06	4 x 6	0,794	533
24020G7K040A04	4 x 4	1,035	879
24020G7K040A02	4 x 2	1,194	1120
24020G7K040A01	4 x 1	1,332	1602
24020G7K040A1C	4 x 1/0	1,465	1907
24020G7K040A2C	4 x 2/0	1,573	2535
24020G7K040A3C	4 x 3/0	1,754	3206
24020G7K040A4C	4 x 4/0	1,964	3765
24020G7K040APC	4 x 262	2,205	4625
24020G7K040AQC	4 x 313	2,374	5367
24020G7K040ANC	4 x 373	2,495	6362
24020G7K040ARC	4 x 444	2,653	7560
24020G7K040AOC	4 x 535	2,989	9284
24020G7K040ASC	4 x 646	3,277	10571
24020G7K050A18	5 x 18	0,418	95
24020G7K050A16	5 x 16	0,437	110
24020G7K050A14	5 x 14	0,479	149
24020G7K050A12	5 x 12	0,550	196
24020G7K050A10	5 x 10	0,604	296
24020G7K050A08	5 x 8	0,765	453
24020G7K050A06	5 x 6	0,914	653
24020G7K050A04	5 x 4	1,137	1073
24020G7K050A02	5 x 2	1,315	1361
24020G7K050A01	5 x 1	1,470	2130
24020G7K050A1C	5 x 1/0	1,618	2550
24020G7K050A2C	5 x 2/0	1,802	2954
24020G7K050A3C	5 x 3/0	2,167	3615

Other dimensions and colors available on request.

GAALSHIP® POWER IEEE type P B

Extremely flexible, 110°C, 0,6/1 kV multi-cores, armoured (B)



Construction:

Conductor:	flexible tinned copper conductor, acc to IEEE 1580 table 11
Insulation:	special cross-linked polyolefin acc. to IEEE type P, and UL 1309/CSA 245 type X110
Cores color:	
<i>two-conductors:</i>	black-white
<i>three-conductors:</i>	black-white-red
<i>four-conductors:</i>	black-white-red-green
<i>five-conductors:</i>	black-white-red-green-orange
Inner sheath:	black (RAL 9005), thermosetting compound acc. to UL 1309/CSA 245 and IEEE 1580
Armouring:	basket weave bronze wire braid acc. to IEEE 1580 and UL 1309/CSA 245

Technical data:

Nominal voltage:	0,6/1 kV
Temperature range:	- 40°C up to + 110°C

Resistance:



Fire retardant acc. to:
IEC 60332-3-22,
IEEE 1202

Features:

Oil abrasion, chemical, moisture, cold resistant
Sunlight resistant
low toxic and corrosive gases emissions
highest ampacity ratings:
ABS 100°C, DNV 95°C, Transport Canada 95°C
NVE 95/16996, FAL
Transport Canada
Det Norske Veritas (DNV)
Lloyd's register of shipping (LRS)
American Bureau of Shipping (ABS)
UL listed as Marine Shipboard Cables
United States Coast Guard November 2, 1987
CSA listed as Marine shipboard cables



on request tinned copper wire braid armouring



Available on stock CABLE GLANDS:
see page 404 up to 416 of catalogue.

GAALSHIP® OFFSHORE CABLES

GAALSHIP® POWER IEEE type P B

Extremely flexible, 110°C, 0,6/1 kV multi-cores, armoured (B)



Part no.	No. of cores x cross section n x AWG/MCM	Ø under armour ca. inches ± 10%	Outer-Ø ca. inches ± 10%	Cable weight approx. lbs/MFt.
24030G7K020A16	2 x 16	0,35	0,4	141
24030G7K020A14	2 x 14	0,38	0,43	165
24030G7K020A12	2 x 12	0,42	0,47	190
24030G7K020A10	2 x 10	0,46	0,51	230
24030G7K020A08	2 x 8	0,6	0,65	327
24030G7K020A06	2 x 6	0,68	0,73	424
24030G7K020A04	2 x 4	0,887	0,937	664
24030G7K020A1C	2 x 1/0	1,243	1,293	1334
24030G7K020A4C	2 x 4/0	1,593	1,643	2271
24030G7K030A16	3 x 16	0,369	0,419	127
24030G7K030A14	3 x 14	0,401	0,451	176
24030G7K030A12	3 x 12	0,445	0,495	212
24030G7K030A10	3 x 10	0,488	0,538	281
24030G7K030A08	3 x 8	0,637	0,687	385
24030G7K030A06	3 x 6	0,732	0,773	519
24030G7K030A04	3 x 4	0,942	0,992	843
24030G7K030A02	3 x 2	1,084	1,134	1160
24030G7K030A01	3 x 1	1,206	1,256	1458
24030G7K030A1C	3 x 1/0	1,326	1,376	1781
24030G7K030A2C	3 x 2/0	1,422	1,472	2082
24030G7K030A3C	3 x 3/0	1,528	1,578	2720
24030G7K030A4C	3 x 4/0	1,765	1,815	3233
24030G7K030APC	3 x 262	1,98	2,030	3880
24030G7K030AQC	3 x 313	2,131	2,181	4434
24030G7K030ANC	3 x 373	2,231	2,281	5219
24030G7K030ARC	3 x 444	2,394	2,444	6176
24030G7K030AOC	3 x 535	2,637	2,678	7492
24030G7K030ASC	3 x 646	2,958	3,008	8414
24030G7K030ATC	3 x 777	3,168	3,218	10065
24030G7K040A16	4 x 16	0,402	0,452	154
24030G7K040A14	4 x 14	0,438	0,488	213
24030G7K040A12	4 x 12	0,486	0,536	256
24030G7K040A10	4 x 10	0,553	0,603	313
24030G7K040A08	4 x 8	0,698	0,748	466
24030G7K040A06	4 x 6	0,794	0,844	669
24030G7K040A04	4 x 4	1,035	1,085	1062
24030G7K040A02	4 x 2	1,194	1,244	1345
24030G7K040A01	4 x 1	1,332	1,382	1909
24030G7K040A1C	4 x 1/0	1,465	1,515	2180
24030G7K040A2C	4 x 2/0	1,573	1,623	2665
24030G7K040A3C	4 x 3/0	1,754	1,804	3578
24030G7K040A4C	4 x 4/0	1,964	2,014	4214
24030G7K040APC	4 x 262	2,205	2,255	4795
24030G7K040AQC	4 x 313	2,374	2,424	5868
24030G7K040ANC	4 x 373	2,495	2,545	6853
24030G7K040ARC	4 x 444	2,653	2,703	7987
24030G7K040AOC	4 x 535	2,989	3,039	9762
24030G7K040ASC	4 x 646	3,277	3,327	10946
24030G7K050A18	5 x 18	0,418	0,468	165
24030G7K050A16	5 x 16	0,437	0,487	189
24030G7K050A14	5 x 14	0,479	0,529	234
24030G7K050A12	5 x 12	0,550	0,6	266
24030G7K050A10	5 x 10	0,604	0,654	406
24030G7K050A08	5 x 8	0,765	0,815	569
24030G7K050A06	5 x 6	0,914	0,964	813
24030G7K050A04	5 x 4	1,137	1,167	1292
24030G7K050A02	5 x 2	1,315	1,365	1637
24030G7K050A01	5 x 1	1,470	1,520	2192
24030G7K050A1C	5 x 1/0	1,618	1,668	2746
24030G7K050A2C	5 x 2/0	1,802	1,852	3301
24030G7K050A3C	5 x 3/0	2,167	2,217	3955

Other dimensions and colors available on request.

GAALSHIP® POWER IEEE type P BS

Extremely flexible, 110°C, 0,6/1 kV multi-cores, armoured and sheathed (BS)

ELETTROTEK KABEL® GAALSHIP® POWER IEEE type P BS



Construction:

- Conductor:** flexible tinned copper conductor, acc to IEEE 1580 table 11
- Insulation:** special cross-linked polyolefin acc. to IEEE type P, and UL 1309/CSA 245 type X110
- Cores color:**
two-conductors: black-white
three-conductors: black-white-red
four-conductors: black-white-red-green
five-conductors: black-white-red-green-orange
- Inner sheath:** thermosetting compound acc. to UL 1309/CSA 245 and IEEE 1580
- Armouring:** basket weave bronze wire braid acc. to IEEE 1580 and UL 1309/CSA 245
- Outer sheath:** black (RAL 9005), thermosetting compound acc. to UL 1309/CSA 245 and IEEE 1580

Technical data:

- Nominal voltage:** 0,6/1 kV
- Temperature range:** - 40°C up to + 110°C

Resistance:



Fire retardant acc. to:
IEC 60332-3-22,
IEEE 1202

Features:

- Oil abrasion, chemical, moisture, cold resistant
- Sunlight resistant
- low toxic and corrosive gases emissions
- highest ampacity ratings:
ABS 100°C, DNV 95°C, Transport Canada 95°C
NVE 95/16996, FAL
Transport Canada
Det Norske Veritas (DNV)
Lloyd's register of shipping (LRS)
American Bureau of Shipping (ABS)
UL listed as Marine Shipboard Cables
United States Coast Guard November 2, 1987
CSA listed as Marine shipboard cables



LISTED

on request tinned copper wire braid armouring



Available on stock CABLE GLANDS:
see page 404 up to 416 of catalogue.

Part no.	No. of cores x cross section n x AWG/MCM	Ø under armour ca. inches ± 10%	Outer-Ø ca. inches ± 10%	Cable weight approx. lbs/Mft.
24040G7K020A16	2 x 16	0,35	0,54	202
24040G7K020A14	2 x 14	0,38	0,561	230
24040G7K020A12	2 x 12	0,42	0,601	263
24040G7K020A10	2 x 10	0,46	0,641	307
24040G7K020A08	2 x 8	0,6	0,781	416
24040G7K020A06	2 x 6	0,68	0,903	559
24040G7K020A04	2 x 4	0,887	1,11	835
24040G7K020A1C	2 x 1/0	1,243	1,466	1562
24040G7K020A4C	2 x 4/0	1,593	1,878	2680
24040G7K030A16	3 x 16	0,369	0,519	181

GAALSHIP® POWER IEEE type P BS

Extremely flexible, 110°C, 0,6/1 kV multi-cores, armoured and sheated (BS)

ELETTROTEK KABEL® GAALSHIP® POWER IEEE type P BS



Part no.	No. of cores x cross section n x AWG/MCM	Ø under armour ca. inches ± 10%	Outer-Ø ca. inches ± 10%	Cable weight approx. lbs/MFt.
24040G7K030A14	3 x 14	0,401	0,583	228
24040G7K030A12	3 x 12	0,445	0,626	276
24040G7K030A10	3 x 10	0,488	0,669	352
24040G7K030A08	3 x 8	0,637	0,818	477
24040G7K030A06	3 x 6	0,732	0,946	650
24040G7K030A04	3 x 4	0,942	1,165	1004
24040G7K030A02	3 x 2	1,084	1,307	1374
24040G7K030A01	3 x 1	1,206	1,431	1675
24040G7K030A1C	3 x 1/0	1,326	1,550	2015
24040G7K030A2C	3 x 2/0	1,422	1,645	2424
24040G7K030A3C	3 x 3/0	1,528	1,814	3106
24040G7K030A4C	3 x 4/0	1,765	2,05	3652
24040G7K030APC	3 x 262	1,98	2,266	4434
24040G7K030AQC	3 x 313	2,131	2,418	4919
24040G7K030ANC	3 x 373	2,231	2,517	5718
24040G7K030ARC	3 x 444	2,394	2,68	6864
24040G7K030AOC	3 x 535	2,637	2,986	8250
24040G7K030ASC	3 x 646	2,958	3,301	9258
24040G7K030ATC	3 x 777	3,168	3,511	10945
24040G7K040A16	4 x 16	0,402	0,583	221
24040G7K040A14	4 x 14	0,438	0,619	262
24040G7K040A12	4 x 12	0,486	0,668	323
24040G7K040A10	4 x 10	0,553	0,734	390
24040G7K040A08	4 x 8	0,698	0,921	591
24040G7K040A06	4 x 6	0,794	1,017	808
24040G7K040A04	4 x 4	1,035	1,258	1236
24040G7K040A02	4 x 2	1,194	1,417	1677
24040G7K040A01	4 x 1	1,332	1,555	2144
24040G7K040A1C	4 x 1/0	1,465	1,75	2434
24040G7K040A2C	4 x 2/0	1,573	1,859	3050
24040G7K040A3C	4 x 3/0	1,754	2,04	4003
24040G7K040A4C	4 x 4/0	1,964	2,249	4670
24040G7K040APC	4 x 262	2,205	2,49	5610
24040G7K040AQC	4 x 313	2,374	2,659	6395
24040G7K040ANC	4 x 373	2,495	2,838	7576
24040G7K040ARC	4 x 444	2,653	3,002	8760
24040G7K040AOC	4 x 535	2,989	3,338	10570
24040G7K040ASC	4 x 646	3,277	3,62	11840
24040G7K050A18	5 x 18	0,418	0,599	214
24040G7K050A16	5 x 16	0,437	0,619	264
24040G7K050A14	5 x 14	0,479	0,660	301
24040G7K050A12	5 x 12	0,550	0,744	334
24040G7K050A10	5 x 10	0,604	0,785	494
24040G7K050A08	5 x 8	0,765	0,988	704
24040G7K050A06	5 x 6	0,914	1,137	973
24040G7K050A04	5 x 4	1,137	1,360	1481
24040G7K050A02	5 x 2	1,315	1,538	1856
24040G7K050A01	5 x 1	1,470	1,756	2482
24040G7K050A1C	5 x 1/0	1,618	1,903	3108
24040G7K050A2C	5 x 2/0	1,802	2,088	3734
24040G7K050A3C	5 x 3/0	2,167	2,453	4592

Other dimensions and colors available on request.

GAALSHIP® CONTROL IEEE type P

Extremely flexible, 110°C, 0,6/1 kV multi-cores, unarmoured

ELETTROTEK KABEL® GAALSHIP® CONTROL IEEE type P



Construction:

Conductor:	flexible tinned copper conductor, acc to IEEE 1580 table 11
Insulation:	special cross-linked polyolefin acc. to IEEE type P, and UL 1309/CSA 245 type X110
Cores color:	acc. to IEEE 1580 table 22
Outer sheath:	black (RAL 9005), thermosetting compound acc. to UL 1309/CSA 245 and IEEE 1580

Technical data:

Nominal voltage:	0,6/1 kV
Temperature range:	- 40°C up to + 110°C

Resistance:



Fire retardant acc. to:
IEC 60332-3-22,
IEEE 1202

Features:

Oil abrasion, chemical, moisture, cold resistant
Sunlight resistant
low toxic and corrosive gases emissions
highest ampacity ratings:
ABS 100°C, DNV 95°C, Transport Canada 95°C
NVE 95/16996, FAL
Transport Canada
Det Norske Veritas (DNV)
Lloyd's register of shipping (LRS)
American Bureau of Shipping (ABS)
UL listed as Marine Shipboard Cables
United States Coast Guard November 2, 1987
CSA listed as Marine shipboard cables



Available on stock **CABLE GLANDS:**
see page 404 up to 416 of catalogue.

GAALSHIP® CONTROL IEEE type P

Extremely flexible, 110°C, 0,6/1 kV multi-cores, unarmoured

ELETTROTEK KABEL® GAALSHIP® CONTROL IEEE type P



Part no.	No. of cores x cross section n x AWG/MCM	Outer-Ø ca. inches ± 10%	Cable weight approx. lbs/Mft.
23010G7K040A16	4 x 16	0,402	99
23010G7K050A16	5 x 16	0,437	110
23010G7K070A16	7 x 16	0,475	155
23010G7K080A16	8 x 16	0,531	164
23010G7K100A16	10 x 16	0,631	206
23010G7K160A16	16 x 16	0,719	299
23010G7K200A16	20 x 16	0,794	360
23010G7K240A16	24 x 16	0,923	462
23010G7K370A16	37 x 16	1,048	658
23010G7K440A16	44 x 16	1,173	807
23010G7K600A16	60 x 16	1,298	1053
23010G7K910A16	91 x 16	1,548	1595
23010G7K040A14	4 x 14	0,438	126
23010G7K050A14	5 x 14	0,479	149
23010G7K060A14	6 x 14	0,539	182
23010G7K070A14	7 x 14	0,539	205
23010G7K080A14	8 x 14	0,691	280
23010G7K100A14	10 x 14	0,713	307
23010G7K160A14	16 x 14	0,749	415
23010G7K200A14	20 x 14	0,916	560
23010G7K240A14	24 x 14	1,013	615
23010G7K370A14	37 x 14	1,071	780
23010G7K440A14	44 x 14	1,153	876
23010G7K600A14	60 x 14	1,293	1087
23010G7K910A14	91 x 14	1,775	2200
23010G7K040A12	4 x 12	0,486	168
23010G7K050A12	5 x 12	0,55	196
23010G7K060A12	6 x 12	0,611	280
23010G7K100A12	10 x 12	0,771	369
23010G7K200A12	20 x 12	1,022	701
23010G7K240A12	24 x 12	1,133	861
23010G7K370A12	37 x 12	1,293	1262

Other dimensions and colors available on request.

GAALSHIP® CONTROL IEEE type P B

Extremely flexible, 110°C, 0,6/1 kV multi-cores, armoured (B)



Construction:

Conductor:	flexible tinned copper conductor, acc to IEEE 1580 table 11
Insulation:	special cross-linked polyolefin acc. to IEEE type P, and UL 1309/CSA 245 type X110
Cores color:	acc. to IEEE 1580 table 22
Inner sheath:	thermosetting compound acc. to UL 1309/CSA 245 and IEEE 1580
Armouring:	basket weave bronze wire braid acc. to IEEE 1580 and UL 1309/CSA 245

Technical data:

Nominal voltage:	0,6/1 kV
Temperature range:	- 40°C up to + 110°C

Resistance:



Fire retardant acc. to:
IEC 60332-3-22,
IEEE 1202

Features:

Oil abrasion, chemical, moisture, cold resistant
Sunlight resistant
low toxic and corrosive gases emissions
highest ampacity ratings:
ABS 100°C, DNV 95°C, Transport Canada 95°C
NVE 95/16996, FAL
Transport Canada
Det Norske Veritas (DNV)
Lloyd's register of shipping (LRS)
American Bureau of Shipping (ABS)
UL listed as Marine Shipboard Cables
United States Coast Guard November 2, 1987
CSA listed as Marine shipboard cables



LISTED

on request tinned copper wire braid armouring



Available on stock CABLE GLANDS:
see page 404 up to 416 of catalogue.

GAALSHIP® CONTROL IEEE type P B

Extremely flexible, 110°C, 0,6/1 kV multi-cores, armoured (B)



Part no.	No. of cores x cross section n x AWG/MCM	Ø under armour ca. inches ± 10%	Outer-Ø ca. inches ± 10%	Cable weight approx. lbs/Mft.
23020G7K040A16	4 x 16	0,402	0,452	154
23020G7K050A16	5 x 16	0,437	0,487	189
23020G7K070A16	7 x 16	0,475	0,525	255
23020G7K080A16	8 x 16	0,531	0,581	265
23020G7K100A16	10 x 16	0,631	0,681	366
23020G7K160A16	16 x 16	0,719	0,769	465
23020G7K200A16	20 x 16	0,794	0,844	560
23020G7K240A16	24 x 16	0,923	0,973	718
23020G7K370A16	37 x 16	1,048	1,098	819
23020G7K440A16	44 x 16	1,173	1,223	980
23020G7K600A16	60 x 16	1,298	1,348	1256
23020G7K910A16	91 x 16	1,548	1,598	1896
23020G7K040A14	4 x 14	0,438	0,488	213
23020G7K050A14	5 x 14	0,479	0,529	234
23020G7K060A14	6 x 14	0,539	0,589	264
23020G7K070A14	7 x 14	0,539	0,589	297
23020G7K080A14	8 x 14	0,691	0,741	406
23020G7K100A14	10 x 14	0,713	0,763	428
23020G7K160A14	16 x 14	0,749	0,799	540
23020G7K200A14	20 x 14	0,916	0,966	812
23020G7K240A14	24 x 14	1,013	1,063	892
23020G7K370A14	37 x 14	1,071	1,121	965
23020G7K440A14	44 x 14	1,153	1,203	1135
23020G7K600A14	60 x 14	1,293	1,343	1260
23020G7K910A14	91 x 14	1,775	1,825	2465
23020G7K040A12	4 x 12	0,486	0,536	256
23020G7K050A12	5 x 12	0,55	0,6	266
23020G7K060A12	6 x 12	0,611	0,661	405
23020G7K100A12	10 x 12	0,771	0,821	500
23020G7K200A12	20 x 12	1,022	1,072	890
23020G7K240A12	24 x 12	1,133	1,183	1167
23020G7K370A12	37 x 12	1,293	1,343	1467

Other dimensions and colors available on request.

GAALSHIP® CONTROL IEEE type P BS

Extremely flexible, 110°C, 0,6/1 kV multi-cores, armoured and sheathed (BS)

ELETTROTEK KABEL® GAALSHIP® POWER IEEE type P BS



Construction:

Conductor:	flexible tinned copper conductor, acc to IEEE 1580 table 11
Insulation:	special cross-linked polyolefin acc. to IEEE type P, and UL 1309/CSA 245 type X110
Cores color:	acc. to IEEE 1580 table 22
Inner sheath:	thermosetting compound acc. to UL 1309/CSA 245 and IEEE 1580
Armouring:	basket weave bronze wire braid acc. to IEEE 1580 and UL 1309/CSA 245
Outer sheath:	black (RAL 9005) thermosetting compound acc. to UL 1309/CSA 245 and IEEE 1580

Technical data:

Nominal voltage:	0,6/1 kV
Temperature range:	- 40°C up to + 110°C

Resistance:



Fire retardant acc. to:
IEC 60332-3-22,
IEEE 1202

Features:

Oil abrasion, chemical, moisture, cold resistant
Sunlight resistant
low toxic and corrosive gases emissions
highest ampacity ratings:
ABS 100°C, DNV 95°C, Transport Canada 95°C
NVE 95/16996, FAL
Transport Canada
Det Norske Veritas (DNV)
Lloyd's register of shipping (LRS)
American Bureau of Shipping (ABS)
UL listed as Marine Shipboard Cables
United States Coast Guard November 2, 1987
CSA listed as Marine shipboard cables



LISTED

on request tinned copper wire braid armouring



Available on stock CABLE GLANDS:
see page 404 up to 416 of catalogue.

GAALSHIP® CONTROL IEEE type P BS

Extremely flexible, 110°C, 0,6/1 kV multi-cores, armoured and sheathed (BS)

ELETTROTEK KABEL® GAALSHIP® POWER IEEE type P BS



Part no.	No. of cores x cross section n x AWG/MCM	Ø under armour ca. inches ± 10%	Outer-Ø ca. inches ± 10%	Cable weight approx. lbs/Mft.
23030G7K040A16	4 x 16	0,402	0,583	227
23030G7K050A16	5 x 16	0,437	0,619	264
23030G7K070A16	7 x 16	0,475	0,656	330
23030G7K080A16	8 x 16	0,531	0,712	340
23030G7K100A16	10 x 16	0,631	0,812	445
23030G7K160A16	16 x 16	0,719	0,942	602
23030G7K200A16	20 x 16	0,794	1,017	724
23030G7K240A16	24 x 16	0,923	1,146	809
23030G7K370A16	37 x 16	1,048	1,271	989
23030G7K440A16	44 x 16	1,173	1,396	1175
23030G7K600A16	60 x 16	1,298	1,521	1496
23030G7K910A16	91 x 16	1,548	1,833	2181
23030G7K040A14	4 x 14	0,438	0,619	262
23030G7K050A14	5 x 14	0,479	0,660	301
23030G7K060A14	6 x 14	0,539	0,72	335
23030G7K070A14	7 x 14	0,539	0,72	377
23030G7K080A14	8 x 14	0,691	0,914	515
23030G7K100A14	10 x 14	0,713	0,936	558
23030G7K160A14	16 x 14	0,749	0,972	665
23030G7K200A14	20 x 14	0,916	1,139	876
23030G7K240A14	24 x 14	1,013	1,236	1132
23030G7K370A14	37 x 14	1,071	1,294	1180
23030G7K440A14	44 x 14	1,153	1,376	1405
23030G7K600A14	60 x 14	1,293	1,516	1477
23030G7K910A14	91 x 14	1,775	2,06	2855
23030G7K040A12	4 x 12	0,486	0,668	323
23030G7K050A12	5 x 12	0,55	0,744	334
23030G7K060A12	6 x 12	0,611	0,792	500
23030G7K100A12	10 x 12	0,771	0,994	629
23030G7K200A12	20 x 12	1,022	1,245	1055
23030G7K240A12	24 x 12	1,133	1,356	1468
23030G7K370A12	37 x 12	1,293	1,516	1677

Other dimensions and colors available on request.

GAALSHIP® VFD IEEE type P

Extremely flexible, 110°C, 2 kV three power cores + three earth cores, unarmoured

ELETTROTEK KABEL® GAALSHIP® VFD IEEE type P



Construction:

Conductor:	flexible tinned copper conductor, acc to IEEE 1580 table 11
Insulation:	special cross-linked polyolefin acc. to IEEE type P, and UL 1309/CSA 245 type X110
Cores color:	gray whit printed phase I.D. (black/white/red)
Earth conductor:	soft annealed tinned flexible stranded copper acc. to IEEE 1580 table 11
Insulation:	insulated and sized acc. to UL 1277
Cores color:	green
Screen:	tinned copper braid and Aluminium/ polyester tape
Outer sheath:	black (RAL 9005) thermosetting compound acc. to UL 1309/CSA 245 and IEEE 1580

Technical data:

Nominal voltage:	2 kV
Temperature range:	- 40°C up to + 110°C

Resistance:



Fire retardant acc. to:
IEC 60332-3-22,
IEEE 1202

Features:

Oil abrasion, chemical, moisture, cold resistant
Sunlight resistant
highest ampacity ratings:
ABS 100°C, DNV 95°C, LRS 95°C, Transport Canada 95°C
NVE 95/16996, FAL
Transport Canada
Det Norske Veritas (DNV)
Lloyd's register of shipping (LRS)
American Bureau of Shipping (ABS)
UL listed as Marine Shipboard Cables
UL listed type TC
United States Coast Guard November 2, 1987



LISTED



Available on stock CABLE GLANDS:
see page 404 up to 416 of catalogue.

Part no.	No. of cores x cross section n x AWG/MCM	Outer-Ø ca. inches ± 10%	Cable weight approx. lbs/MFt.
2601017K037A14	3x14+3G18	0,63	211
2601017K037A12	3x12+3G18	0,675	282
2601017K037A10	3x10+3G14	0,75	371
2601017K037A08	3x8+3G14	0,805	463
2601017K037A06	3x6+3G12	0,91	656
2601017K037A04	3x4+3G12	1,094	925
2601017K037A02	3x2+3G10	1,235	1271
2601017K037A01	3x1+3G10	1,341	1585
2601017K037A1C	3x1/0+3G10	1,45	1896
2601017K037A2C	3x2/0+3G10	1,58	2311
2601017K037A4C	3x4/0+3G8	1,9	3457
2601017K037APC	3x262+3G6	2,05	4177
2601017K037AQC	3x313+3G6	2,13	4786
2601017K037ANC	3x373+3G6	2,275	5521
2601017K037ARC	3x444+3G6	2,425	6440
2601017K037AOC	3x535+3G6	2,643	7848
2601017K037ASC	3x646+3G4	2,92	9213
2601017K037ATC	3x777+3G4	3,102	10909

Other dimensions and colors available on request.

GAALSHIP® VFD IEEE type P TS

Extremely flexible, 110°C, 2 kV three power cores + three earth cores, unarmoured (TS)

ELETTROTEK KABEL® GAALSHIP® VFD IEEE type P TS



Construction:

- Conductor:** flexible tinned copper conductor, acc to IEEE 1580 table 11
- Insulation:** special cross-linked polyolefin acc. to IEEE type P, and UL 1309/CSA 245 type X110
- Cores color:** gray whit printed phase I.D. (black/white/red)
- Earth conductor:** soft annealed tinned flexible stranded copper acc. to IEEE 1580 table 11
- Insulation:** insulated and sized acc. to UL 1277
- Cores color:** green
- Screen:** tinned copper braid and Aluminium/ polyester tape
- Inner sheath:** thermosetting compound acc. to UL 1309/CSA 245 and IEEE 1580
- Armouring:** basket weave tinned copper wire acc. to IEEE 1580 and UL 1309/CSA 245
- Outer sheath:** black, thermosetting compound acc. to UL 1309/CSA 245 and IEEE 1580

Technical data:

- Nominal voltage:** 2 kV
- Temperature range:** - 40°C up to + 110°C

Resistance:



Fire retardant acc. to:
IEC 60332-3-22,
IEEE 1202

Features:

- Oil abrasion, chemical, moisture, cold resistant
- Sunlight resistant
- highest ampacity ratings:
ABS 100°C, DNV 95°C, LRS 95°C, Transport Canada 95°C
- NVE 95/16996, FAL
- Transport Canada
- Det Norske Veritas (DNV)
- Lloyd's register of shipping (LRS)
- American Bureau of Shipping (ABS)
- UL listed as Marine Shipboard Cables
- UL listed type TC
- United States Coast Guard November 2, 1987



LISTED

on request braid of bronze, aluminium or tinned copper



Available on stock CABLE GLANDS:
see page 404 up to 416 of catalogue.

Part no.	No. of cores x cross section n x AWG/MCM	Ø under armour ca. inches ± 10%	Outer-Ø ca. inches ± 10%	Cable weight approx. lbs/MFt.
2602017K037A14	3x14+3G18	0,63	0,772	349
2602017K037A12	3x12+3G18	0,675	0,795	383
2602017K037A10	3x10+3G14	0,75	0,918	518
2602017K037A08	3x8+3G14	0,805	0,973	616
2602017K037A06	3x6+3G12	0,91	1,098	832
2602017K037A04	3x4+3G12	1,094	1,262	1128
2602017K037A02	3x2+3G10	1,235	1,393	1512
2602017K037A01	3x1+3G10	1,341	1,509	1836
2602017K037A1C	3x1/0+3G10	1,45	1,615	2137
2602017K037A2C	3x2/0+3G10	1,58	1,792	2660
2602017K037A4C	3x4/0+3G8	1,9	2,101	3864
2602017K037APC	3x262+3G6	2,05	2,258	4661
2602017K037AQC	3x313+3G6	2,13	2,354	5288
2602017K037ANC	3x373+3G6	2,275	2,483	6052
2602017K037ARC	3x444+3G6	2,425	2,633	6994
2602017K037AOC	3x535+3G6	2,643	2,931	8478
2602017K037ASC	3x646+3G4	2,92	3,178	9888
2602017K037ATC	3x777+3G4	3,102	3,39	11803

Other dimensions and colors available on request.

GAALSHIP® MEDIUM IEEE type E SC

90°C, 5 kV - 8 kV - 15 kV, single-core, 100% & 133% insulation level, unarmoured

ELETTROTEK KABEL® GAALSHIP® MEDIUM IEEE type E SC



Construction:

Conductor:	flexible tinned copper conductor, acc to IEEE 1580 table 11
Semi-conductive layer:	semi-conductive tape + extruded thermosetting semi-conductive material acc. to UL 1309, IEEE 1580 and UL 1072
Insulation:	extruded thermosetting EPR compound 90°C acc. to UL 1309 Type E, IEEE 1580 Type E and UL 1072
Semi-conductive layer:	semi-conductive tape acc. to UL 1309, IEEE 1580 and UL 1072
Screen:	nylon tape with overall tinned copper braiding acc. to UL 1309, IEEE 1580 and UL 1072
Outer sheath:	black (RAL 9005) thermosetting compound acc. to UL 1309 IEEE 1580 and UL 1072 on request different sheath colors to distinguish the different levels of voltage: 5 kV = yellow outer sheath 8 kV = orange outer sheath 15 kV = red outer sheath

Resistance:



Fire retardant acc. to:
IEC 60332-3-22,
IEEE 1202

Technical data:

Nominal voltage:	5 kV 8 kV 15 kV
Temperature range:	up to +90°C
Min. bending radius:	6 x d

Features:

Oil abrasion, chemical, moisture, cold resistant
Sunlight resistant
Det Norske Veritas (DNV)
Lloyd's register of shipping (LRS)
American Bureau of Shipping (ABS)
UL listed as Marine Shipboard Cables



LISTED



Available on stock CABLE GLANDS:
see page 404 up to 416 of catalogue.

GAALSHIP® OFFSHORE CABLES

GAALSHIP® MEDIUM IEEE type E SC

90°C, 5 kV - 8 kV - 15 kV, single-core, 100% & 133% insulation level, unarmoured

ELETTROTEK KABEL® GAALSHIP® MEDIUM IEEE type E SC



5 kV, 100% & 133% insulation level

Part no.	No. of cores x cross section n x AWG/MCM	Outer-Ø ca. inches ± 10%	Cable weight approx. lbs/MFt.
2501027L010A08	1 x 8	0,564	204
2501027L010A06	1 x 6	0,604	252
2501027L010A04	1 x 4	0,686	344
2501027L010A02	1 x 2	0,75	449
2501027L010A01	1 x 1	0,79	528
2501027L010A1C	1 x 1/0	0,877	659
2501027L010A2C	1 x 2/0	0,937	787
2501027L010A3C	1 x 3/0	0,98	910
2501027L010A4C	1 x 4/0	1,042	1086
2501027L010APC	1 x 262	1,121	1272
2501027L010AQC	1 x 313	1,187	1467
2501027L010ANC	1 x 373	1,252	1692
2501027L010ARC	1 x 444	1,327	1968
2501027L010AOC	1 x 535	1,408	2294
2501027L010ASC	1 x 646	1,496	2672
2501027L010ATC	1 x 777	1,599	3154
2501027L010AUC	1 x 1111	1,883	4414

8 kV, 100% insulation level

Part no.	No. of cores x cross section n x AWG/MCM	Outer-Ø ca. inches ± 10%	Cable weight approx. lbs/MFt.
25010P7L010A06	1 x 6	0,656	283
25010P7L010A04	1 x 4	0,738	378
25010P7L010A02	1 x 2	0,801	486
25010P7L010A01	1 x 1	0,884	604
25010P7L010A1C	1 x 1/0	0,929	702
25010P7L010A2C	1 x 2/0	0,989	835
25010P7L010A3C	1 x 3/0	1,032	956
25010P7L010A4C	1 x 4/0	1,094	1135
25010P7L010APC	1 x 262	1,173	1324
25010P7L010AQC	1 x 313	1,239	1522
25010P7L010ANC	1 x 373	1,304	1750
25010P7L010ARC	1 x 444	1,379	2029
25010P7L010AOC	1 x 535	1,46	2359
25010P7L010ASC	1 x 646	1,548	2741
25010P7L010ATC	1 x 777	1,651	3186
25010P7L010AUC	1 x 1111	1,935	4498

8 kV, 133% insulation level

Part no.	No. of cores x cross section n x AWG/MCM	Outer-Ø ca. inches ± 10%	Cable weight approx. lbs/MFt.
25011P7L010A06	1 x 6	0,71	317
25011P7L010A04	1 x 4	0,792	417
25011P7L010A02	1 x 2	0,898	565
25011P7L010A01	1 x 1	0,938	648
25011P7L010A1C	1 x 1/0	0,983	751
25011P7L010A2C	1 x 2/0	1,043	884
25011P7L010A3C	1 x 3/0	1,086	1007
25011P7L010A4C	1 x 4/0	1,148	1189
25011P7L010APC	1 x 262	1,227	1381
25011P7L010AQC	1 x 313	1,293	1584
25011P7L010ANC	1 x 373	1,358	1813
25011P7L010ARC	1 x 444	1,433	2095
25011P7L010AOC	1 x 535	1,46	2359
25011P7L010ASC	1 x 646	1,602	2814
25011P7L010ATC	1 x 777	1,767	3376
25011P7L010AUC	1 x 1111	1,989	4587

GAALSHIP® MEDIUM IEEE type E SC

90°C, 5 kV - 8 kV - 15 kV, single-core, 100% & 133% insulation level, unarmoured

ELETTROTEK KABEL® GAALSHIP® MEDIUM IEEE type E SC



15 kV, 100% insulation level

Part no.	No. of cores x cross section n x AWG/MCM	Outer-Ø ca. inches ± 10%	Cable weight approx. lbs/MFt.
25010T7L010A04	1 x 2	1,05	692
25010T7L010A02	1 x 1	1,088	778
25010T7L010A01	1 x 1/0	1,133	883
25010T7L010A1C	1 x 2/0	1,191	1024
25010T7L010A2C	1 x 3/0	1,236	1154
25010T7L010A3C	1 x 4/0	1,298	1343
25010T7L010APC	1 x 262	1,397	1568
25010T7L010AQC	1 x 313	1,463	1778
25010T7L010ANC	1 x 373	1,528	2015
25010T7L010ARC	1 x 444	1,603	2313
25010T7L010AOC	1 x 535	1,742	2762
25010T7L010ASC	1 x 646	1,83	3165
25010T7L010ATC	1 x 777	1,965	3729
25010T7L010AUC	1 x 1111	2,187	4930

15 kV, 133% insulation level

Part no.	No. of cores x cross section n x AWG/MCM	Outer-Ø ca. inches ± 10%	Cable weight approx. lbs/MFt.
25011T7L010A02	1 x 2	1,132	771
25011T7L010A01	1 x 1	1,17	863
25011T7L010A1C	1 x 1/0	1,215	970
25011T7L010A2C	1 x 2/0	1,273	1112
25011T7L010A3C	1 x 3/0	1,338	1267
25011T7L010A4C	1 x 4/0	1,4	1461
25011T7L010APC	1 x 262	1,479	1670
25011T7L010AQC	1 x 313	1,545	1884
25011T7L010ANC	1 x 373	1,61	2132
25011T7L010ARC	1 x 444	1,747	2541
25011T7L010AOC	1 x 535	1,824	2889
25011T7L010ASC	1 x 646	1,944	3350
25011T7L010ATC	1 x 777	2,047	3870
25011T7L010AUC	1 x 1111	2,269	5083

Other dimensions and colors available on request.
25 kV version available on request.

GAALSHIP® MEDIUM IEEE type E SC BS

90°C, 5 kV - 8 kV - 15 kV, single-core, 100% & 133% insulation level, armoured and sheathed (BS)

ELETTROTEK KABEL® GAALSHIP® MEDIUM IEEE type E SC BS



Construction:

Conductor:	flexible tinned copper conductor, acc to IEEE 1580 table 11
Semi-conductive layer:	semi-conductive tape + extruded thermosetting semi-conductive material acc. to UL 1309, IEEE 1580 and UL 1072
Insulation:	extruded thermosetting EPR compound 90°C acc. to UL 1309 Type E, IEEE 1580 Type E and UL 1072
Semi-conductive layer:	semi-conductive tape acc. to UL 1309, IEEE 1580 and UL 1072
Screen:	nylon tape with overall tinned copper braiding acc. to UL 1309, IEEE 1580 and UL 1072
Inner sheath:	thermosetting compound acc. to UL 1309 IEEE 1580 and UL 1072 on request different sheath colors to distinguish the different levels of voltage: 5 kV = yellow outer sheath 8 kV = orange outer sheath 15 kV = red outer sheath
Armouring:	bronze braiding acc. to UL 1309, IEEE Std. 45-1998
Outer sheath:	black (RAL 9005) thermosetting compound acc. to UL 1309 IEEE 1580 and UL 1072 on request different sheath colors to distinguish the different levels of voltage: 5 kV = yellow outer sheath 8 kV = orange outer sheath 15 kV = red outer sheath

Technical data:

Nominal voltage:	5 kV 8 kV 15 kV
Temperature range:	up to +90°C
Min. bending radius:	8 x d

Resistance:



Fire retardant acc. to:
IEC 60332-3-22,
IEEE 1202

Features:

Oil abrasion, chemical, moisture, cold resistant
Sunlight resistant
Det Norske Veritas (DNV)
Lloyd's register of shipping (LRS)
American Bureau of Shipping (ABS)
UL listed as Marine Shipboard Cables



LISTED



Available on stock CABLE GLANDS:
see page 404 up to 416 of catalogue.

GAALSHIP® MEDIUM IEEE type E SC BS

90°C, 5 kV - 8 kV - 15 kV, single-core, 100% & 133% insulation level, armoured and sheathed (BS)

ELETTROTEK KABEL® GAALSHIP® MEDIUM IEEE type E SC BS



5 kV, 100% & 133% insulation level

Part no.	No. of cores x cross section n x AWG/MCM	Ø under armour ca. inches ± 10%	Outer-Ø ca. inches ± 10%	Cable weight approx. lbs/MFt.
2502027L010A08	1 x 8	0,564	0,751	401
2502027L010A06	1 x 6	0,604	0,836	502
2502027L010A04	1 x 4	0,686	0,918	622
2502027L010A02	1 x 2	0,75	0,981	748
2502027L010A01	1 x 1	0,79	1,064	894
2502027L010A1C	1 x 1/0	0,877	1,108	1004
2502027L010A2C	1 x 2/0	0,937	1,168	1160
2502027L010A3C	1 x 3/0	0,98	1,212	1298
2502027L010A4C	1 x 4/0	1,042	1,274	1496
2502027L010APC	1 x 262	1,121	1,353	1708
2502027L010AQC	1 x 313	1,187	1,419	1926
2502027L010ANC	1 x 373	1,252	1,484	2174
2502027L010ARC	1 x 444	1,327	1,559	2476
2502027L010AOC	1 x 535	1,408	1,706	2949
2502027L010ASC	1 x 646	1,496	1,793	3361
2502027L010ATC	1 x 777	1,599	1,881	3859
2502027L010AUC	1 x 1111	1,883	2,169	5255

8 kV, 100% insulation level

Part no.	No. of cores x cross section n x AWG/MCM	Ø under armour ca. inches ± 10%	Outer-Ø ca. inches ± 10%	Cable weight approx. lbs/MFt.
25020P7L010A06	1 x 6	0,656	0,888	549
25020P7L010A04	1 x 4	0,738	0,97	673
25020P7L010A02	1 x 2	0,801	1,033	806
25020P7L010A01	1 x 1	0,884	1,108	942
25020P7L010A1C	1 x 1/0	0,929	1,16	1072
25020P7L010A2C	1 x 2/0	0,989	1,22	1226
25020P7L010A3C	1 x 3/0	1,032	1,264	1363
25020P7L010A4C	1 x 4/0	1,094	1,326	1563
25020P7L010APC	1 x 262	1,173	1,405	1779
25020P7L010AQC	1 x 313	1,239	1,471	1999
25020P7L010ANC	1 x 373	1,304	1,536	2250
25020P7L010ARC	1 x 444	1,379	1,603	2538
25020P7L010AOC	1 x 535	1,46	1,746	3012
25020P7L010ASC	1 x 646	1,548	1,833	3428
25020P7L010ATC	1 x 777	1,651	1,949	3944
25020P7L010AUC	1 x 1111	1,935	2,233	5388

8 kV, 133% insulation level

Part no.	No. of cores x cross section n x AWG/MCM	Ø under armour ca. inches ± 10%	Outer-Ø ca. inches ± 10%	Cable weight approx. lbs/MFt.
25021P7L010A06	1 x 6	0,71	0,942	603
25021P7L010A04	1 x 4	0,792	1,016	725
25021P7L010A02	1 x 2	0,898	1,129	916
25021P7L010A01	1 x 1	0,938	1,17	1022
25021P7L010A1C	1 x 1/0	0,983	1,214	1140
25021P7L010A2C	1 x 2/0	1,043	1,274	1293
25021P7L010A3C	1 x 3/0	1,086	1,318	1432
25021P7L010A4C	1 x 4/0	1,148	1,38	1635
25021P7L010APC	1 x 262	1,227	1,459	1854
25021P7L010AQC	1 x 313	1,293	1,524	2081
25021P7L010ANC	1 x 373	1,358	1,582	2318
25021P7L010ARC	1 x 444	1,433	1,719	2734
25021P7L010AOC	1 x 535	1,46	1,758	3034
25021P7L010ASC	1 x 646	1,602	1,888	3529
25021P7L010ATC	1 x 777	1,767	2,065	4181
25021P7L010AUC	1 x 1111	1,989	2,275	5470

GAALSHIP® MEDIUM IEEE type E SC BS

90°C, 5 kV - 8 kV - 15 kV, single-core, 100% & 133% insulation level, armoured and sheathed (BS)

ELETTROTEK KABEL® GAALSHIP® MEDIUM IEEE type E SC BS



15 kV, 100% insulation level

Part no.	No. of cores x cross section n x AWG/MCM	Ø under armour ca. inches ± 10%	Outer-Ø ca. inches ± 10%	Cable weight approx. lbs/MFt.
25020T7L010A02	1 x 2	1,05	1,269	1088
25020T7L010A01	1 x 1	1,088	1,308	1186
25020T7L010A1C	1 x 1/0	1,133	1,352	1301
25020T7L010A2C	1 x 2/0	1,191	1,41	1462
25020T7L010A3C	1 x 3/0	1,236	1,456	1608
25020T7L010A4C	1 x 4/0	1,298	1,518	1817
25020T7L010APC	1 x 262	1,397	1,616	2077
25020T7L010AQC	1 x 313	1,463	1,744	2422
25020T7L010ANC	1 x 373	1,528	1,809	2685
25020T7L010ARC	1 x 444	1,603	1,884	3014
25020T7L010AOC	1 x 535	1,742	2,024	3520
25020T7L010ASC	1 x 646	1,83	2,112	3960
25020T7L010ATC	1 x 777	1,965	2,246	4578
25020T7L010AUC	1 x 1111	2,187	2,468	5870

15 kV, 133% insulation level

Part no.	No. of cores x cross section n x AWG/MCM	Ø under armour ca. inches ± 10%	Outer-Ø ca. inches ± 10%	Cable weight approx. lbs/MFt.
25021T7L010A02	1 x 2	1,132	1,352	1194
25021T7L010A01	1 x 1	1,17	1,39	1299
25021T7L010A1C	1 x 1/0	1,215	1,434	1416
25021T7L010A2C	1 x 2/0	1,273	1,492	1578
25021T7L010A3C	1 x 3/0	1,338	1,558	1756
25021T7L010A4C	1 x 4/0	1,4	1,62	1971
25021T7L010APC	1 x 262	1,479	1,761	2320
25021T7L010AQC	1 x 313	1,545	1,827	2561
25021T7L010ANC	1 x 373	1,61	1,892	2836
25021T7L010ARC	1 x 444	1,747	2,029	3301
25021T7L010AOC	1 x 535	1,824	2,106	3680
25021T7L010ASC	1 x 646	1,944	2,226	4191
25021T7L010ATC	1 x 777	2,047	2,329	4753
25021T7L010AUC	1 x 1111	2,269	2,551	6057

Other dimensions and colors available on request.
25 kV version available on request.

GAALSHIP® MEDIUM IEEE type E

90°C, 5 kV - 8 kV - 15 kV, three power-cores + (grounding-core on request), 100% & 133% insulation level, unarmoured

ELETTROTEK KABEL® GAALSHIP® MEDIUM IEEE type E



Construction:

Conductor: flexible tinned copper conductor, acc to IEEE 1580 table 11

Semi-conductive layer: semi-conductive tape + extruded thermosetting semi-conductive material acc. to UL 1309, IEEE 1580 and UL 1072

Insulation: extruded thermosetting EPR compound 90°C acc. to UL 1309 Type E, IEEE 1580 Type E and UL 1072

Semi-conductive layer: semi-conductive tape acc. to UL 1309, IEEE 1580 and UL 1072

Screen: nylon tape with overall tinned copper braiding acc. to UL 1309, IEEE 1580 and UL 1072
each nylon tape is colored for easy phase identification (black, blue, red)

Grounding conductor: one soft annealed tinned flexible stranded copper conductor without insulation acc. to ASTM B 33 and sized acc. to UL 1072 table 21.1

Outer sheath: black (RAL 9005) thermosetting compound acc. to UL 1309 IEEE 1580 and UL 1072 on request different sheath colors to distinguish the different levels of voltage: 5 kV = yellow outer sheath
8 kV = orange outer sheath
15 kV = red outer sheath

Technical data:

Nominal voltage: 5 kV
8 kV
15 kV

Temperature range: up to +90°C

Min. bending radius: 6 x d

Resistance:



Fire retardant acc. to:
IEC 60332-3-22,
IEEE 1202

Features:

Oil abrasion, chemical, moisture, cold resistant
Sunlight resistant
Det Norske Veritas (DNV)
Lloyd's register of shipping (LRS)
American Bureau of Shipping (ABS)
UL listed as Marine Shipboard Cables



Available on stock CABLE GLANDS:
see page 404 up to 416 of catalogue.

GAALSHIP® OFFSHORE CABLES

GAALSHIP® MEDIUM IEEE type E

90°C, 5 kV - 8 kV - 15 kV, three power-cores + (grounding-core on request), 100% & 133% insulation level, unarmoured

ELETTROTEK KABEL® GAALSHIP® MEDIUM IEEE type E



5 kV, 100% & 133% insulation level

Part no.	No. of cores x cross section n x AWG/MCM	Outer-Ø ca. inches ± 10%	Cable weight approx. lbs/MFt.
2503027K030A08	3x8 (+1x8)	1,137	781
2503027K030A06	3x6 (+1x6)	1,226	955
2503027K030A04	3x4 (+1x6)	1,402	1307
2503027K030A02	3x2 (+1x6)	1,538	1690
2503027K030A01	3x1 (+1x4)	1,626	1974
2503027K030A1C	3x1/0 (+1x4)	1,783	2423
2503027K030A2C	3x2/0 (+1x4)	1,913	2884
2503027K030A3C	3x3/0 (+1x3)	2,007	3315
2503027K030A4C	3x4/0 (+1x3)	2,14	3937
2503027K030APC	3x262 (+1x3)	2,31	4619
2503027K030AQC	3x313 (+1x2)	2,453	5319
2503027K030ANC	3x373 (+1x2)	2,589	6107
2503027K030ARC	3x444 (+1x1)	2,818	7280
2503027K030AOC	3x535 (+1X1)	2,974	8463
2503027K030ASC	3x646 (+1x1)	3,164	9814
2503027K030ATC	3x777(+1x1/0)	3,385	11526

8 kV, 100% insulation level

Part no.	No. of cores x cross section n x AWG/MCM	Outer-Ø ca. inches ± 10%	Cable weight approx. lbs/MFt.
25030P7K030A06	3x6 (+1x6)	1,338	1094
25030P7K030A04	3x4 (+1x6)	1,514	1462
25030P7K030A02	3x2 (+1x6)	1,65	1970
25030P7K030A01	3x1(+1x4)	1,8	2263
25030P7K030A1C	3x1/0 (+1x4)	1,895	2617
25030P7K030A2C	3x2/0 (+1x4)	2,025	3100
25030P7K030A3C	3x3/0 (+1x3)	2,119	3531
25030P7K030A4C	3x4/0 (+1x3)	2,252	4162
25030P7K030APC	3x262 (+1x3)	2,422	4864
25030P7K030AQC	3x313 (+1x2)	2,565	5581
25030P7K030ANC	3x373 (+1x2)	2,704	6392
25030P7K030ARC	3x444 (+1x1)	2,93	7582
25030P7K030AOC	3x535 (+1x1)	3,096	8806
25030P7K030ASC	3x646 (+1x1)	3,267	10137
25030P7K030ATC	3x777(+1x1/0)	3,512	11959

8 kV, 133% insulation level

Part no.	No. of cores x cross section n x AWG/MCM	Outer-Ø ca. inches ± 10%	Cable weight approx. lbs/MFt.
25031P7K030A06	3x6 (+1x6)	1,454	1249
25031P7K030A04	3x4 (+1x6)	1,63	1639
25031P7K030A02	3x2 (+1x6)	1,829	2162
25031P7K030A01	3x1 (+1x4)	1,916	2467
25031P7K030A1C	3x1/0 (+1x4)	2,012	2838
25031P7K030A2C	3x2/0 (+1x4)	2,141	3327
25031P7K030A3C	3x3/0 (+1x3)	2,236	3763
25031P7K030A4C	3x4/0 (+1x3)	2,369	4417
25031P7K030APC	3x262 (+1x3)	2,539	5133
25031P7K030AQC	3x313 (+1x2)	2,68	5870
25031P7K030ANC	3x373 (+1x2)	2,885	6884
25031P7K030ARC	3x444 (+1x1)	3,036	7959
25031P7K030AOC	3x535 (+1x1)	3,21	9167
25031P7K030ASC	3x646 (+1x1)	3,4	10554

GAALSHIP® MEDIUM IEEE type E

90°C, 5 kV - 8 kV - 15 kV, three power-cores + (grounding-core on request), 100% & 133% insulation level, unarmoured

ELETTROTEK KABEL® GAALSHIP® MEDIUM IEEE type E



15 kV, 100% & 133% insulation level

Part no.	No. of cores x cross section n x AWG/MCM	Outer-Ø ca. inches ± 10%	Cable weight approx. lbs/MFt.
25030T7K030A02	3x2 (+1x6)	2,157	2759
25030T7K030A01	3x1 (+1x4)	2,239	3073
25030T7K030A1C	3x1/0 (+1x4)	2,335	3466
25030T7K030A2C	3x2/0 (+1x4)	2,461	3991
25030T7K030A3C	3x3/0 (+1x3)	2,559	4466
25030T7K030A4C	3x4/0 (+1x3)	2,691	5150
25030T7K030APC	3x262 (+1x3)	2,539	5133
25030T7K030AQC	3x313 (+1x2)	2,881	6483
25030T7K030ANC	3x373 (+1x2)	3,021	7331
25030T7K030ARC	3x444 (+1x1)	3,183	8380
25030T7K030AOC	3x535 (+1x1)	3,357	9599

15 kV, 133% insulation level

Part no.	No. of cores x cross section n x AWG/MCM	Outer-Ø ca. inches ± 10%	Cable weight approx. lbs/MFt.
25031T7K030A02	3x2 (+1x6)	2,334	3125
25031T7K030A01	3x1 (+1x4)	2,416	3470
25031T7K030A1C	3x1/0 (+1x4)	2,512	3874
25031T7K030A2C	3x2/0 (+1x4)	2,637	4411
25031T7K030A3C	3x3/0 (+1x3)	2,842	5206
25031T7K030A4C	3x4/0 (+1x3)	2,976	5930
25031T7K030APC	3x262 (+1x3)	2,989	6412
25031T7K030AQC	3x313 (+1x2)	3,091	6990
25031T7K030ANC	3x373 (+1x2)	3,204	7897
25031T7K030ARC	3x444 (+1x1)	3,347	8879
25031T7K030AOC	3x535 (+1x1)	3,521	10144

Other dimensions and colors available on request.
25 kV version available on request.

GAALSHIP® MEDIUM IEEE type E BS

90°C, 5 kV - 8 kV - 15 kV, three power-cores + (grounding-core on request), 100% & 133% insulation level, armoured and sheathed (BS)

ELETTROTEK KABEL® GAALSHIP® MEDIUM IEEE type E BS

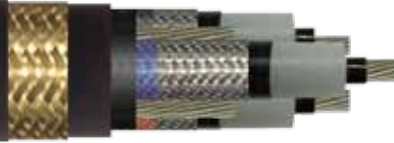

Construction:

Conductor: flexible tinned copper conductor, acc to IEEE 1580 table 11

Semi-conductive layer: semi-conductive tape + extruded thermosetting semi-conductive material acc. to UL 1309, IEEE 1580 and UL 1072

Insulation: extruded thermosetting EPR compound 90°C acc. to UL 1309 Type E, IEEE 1580 Type E and UL 1072

Semi-conductive layer: semi-conductive tape acc. to UL 1309, IEEE 1580 and UL 1072

Screen: nylon tape with overall tinned copper braiding acc. to UL 1309, IEEE 1580 and UL 1072
each nylon tape is colored for easy phase identification (black, blue, red)

Grounding conductor: one soft annealed tinned flexible stranded copper conductor without insulation acc. to ASTM B 33 and sized acc. to UL 1072 table 21.1

Inner sheath: thermosetting compound acc. to UL 1309 IEEE 1580 and UL 1072
on request different sheath colors to distinguish the different levels of voltage:
5 kV = yellow outer sheath
8 kV = orange outer sheath
15 kV = red outer sheath

Armouring: bronze braiding acc. to UL 1309, IEEE Std. 45-1998

Outer sheath: black (RAL 9005) thermosetting compound acc. to UL 1309 IEEE 1580 and UL 1072
on request different sheath colors to distinguish the different levels of voltage: 5 kV = yellow outer sheath
8 kV = orange outer sheath
15 kV = red outer sheath

Technical data:

Nominal voltage: 5 kV
8 kV
15 kV

Temperature range: up to +90°C

Min. bending radius: 8 x d

Resistance:



Fire retardant acc. to:
IEC 60332-3-22,
IEEE 1202

Features:

Oil abrasion, chemical, moisture, cold resistant
Sunlight resistant
Det Norske Veritas (DNV)
Lloyd's register of shipping (LRS)
American Bureau of Shipping (ABS)
UL listed as Marine Shipboard Cables



LISTED



Available on stock CABLE GLANDS:
see page 404 up to 416 of catalogue.

GAALSHIP® MEDIUM IEEE type E BS

90°C, 5 kV - 8 kV - 15 kV, three power-cores + (grounding-core on request), 100% & 133% insulation level, armoured and sheathed (BS)

ELETTROTEK KABEL® GAALSHIP® MEDIUM IEEE type E BS

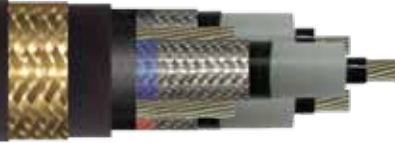

5 kV, 100% & 133% insulation level

Part no.	No. of cores x cross section n x AWG/MCM	Ø under armour ca. inches ± 10%	Outer-Ø ca. inches ± 10%	Cable weight approx. lbs/MFt.
2504027K030A08	3x8 (+1x8)	1,137	1,369	1218
2504027K030A06	3x6 (+1x6)	1,226	1,457	1424
2504027K030A04	3x4 (+1x6)	1,402	1,625	1824
2504027K030A02	3x2 (+1x6)	1,538	1,824	2372
2504027K030A01	3x1 (+1x4)	1,626	1,911	2692
2504027K030A1C	3x1/0(+1x4)	1,783	2,081	3232
2504027K030A2C	3x2/0(+1x4)	1,913	2,21	3749
2504027K030A3C	3x3/0(+1x3)	2,007	2,305	4220
2504027K030A4C	3x4/0 (+1x3)	2,14	2,438	4899
2504027K030APC	3x262 (+1x3)	2,31	2,608	5654
2504027K030AQC	3x313 (+1x2)	2,453	2,796	6549
2504027K030ANC	3x373 (+1x2)	2,589	3	7402
2504027K030ARC	3x444 (+1x1)	2,818	3,161	8684
2504027K030AOC	3x535 (+1x1)	2,974	3,317	9964
2504027K030ASC	3x646 (+1x1)	3,164	3,507	11407
2504027K030ATC	3x777 (+1x1/0)	3,385	3,729	13226

8 kV, 100% insulation level

Part no.	No. of cores x cross section n x AWG/MCM	Ø under armour ca. inches ± 10%	Outer-Ø ca. inches ± 10%	Cable weight approx. lbs/MFt.
25040P7K030A08	3x6 (+1x6)	1,338	1,561	1589
25040P7K030A06	3x4 (+1x6)	1,514	1,799	2134
25040P7K030A04	3x2 (+1x6)	1,65	1,996	2725
25040P7K030A02	3x1 (+1x4)	1,8	2,085	3054
25040P7K030A01	3x1/0 (+1x4)	1,895	2,181	3454
25040P7K030A1C	3x2/0 (+1x4)	2,025	2,31	3989
25040P7K030A2C	3x3/0 (+1x3)	2,119	2,404	4458
25040P7K030A3C	3x4/0 (+1x3)	2,252	2,537	5140
25040P7K030A4C	3x262 (+1x3)	2,422	2,707	5913
25040P7K030APC	3x313 (+1x2)	2,565	2,914	6884
25040P7K030AQC	3x373 (+1x2)	2,704	3,054	7760
25040P7K030ARC	3x444 (+1x1)	2,93	3,28	9059
25040P7K030AOC	3x535 (+1x1)	3,096	3,439	10366
25040P7K030ASC	3x646 (+1x1)	3,267	3,611	11780
25040P7K030ATC	3x777(+1x1/0)	3,512	3,855	13708

8 kV, 133% insulation level

Part no.	No. of cores x cross section n x AWG/MCM	Ø under armour ca. inches ± 10%	Outer-Ø ca. inches ± 10%	Cable weight approx. lbs/MFt.
25041P7K030A08	3x6 (+1x6)	1,454	1,74	1896
25041P7K030A06	3x4 (+1x6)	1,63	1,916	2359
25041P7K030A04	3x2 (+1x6)	1,829	2,114	2964
25041P7K030A02	3x1 (+1x4)	1,916	2,202	3306
25041P7K030A01	3x1/0 (+1x4)	2,012	2,297	3717
25041P7K030A1C	3x2/0 (+1x4)	2,141	2,427	4259
25041P7K030A2C	3x3/0 (+1x3)	2,236	2,521	4734
25041P7K030A3C	3x4/0 (+1x3)	2,369	2,654	5443
25041P7K030APC	3x262 (+1x3)	2,539	2,888	6442
25041P7K030AQC	3x313 (+1x2)	2,68	3,031	7227
25041P7K030ANC	3x373 (+1x2)	2,885	3,235	8340
25041P7K030ARC	3x444 (+1x1)	3,036	3,38	9491
25041P7K030AOC	3x535 (+1x1)	3,21	3,552	10782
25041P7K030ASC	3x646 (+1x1)	3,4	3,742	12261

GAALSHIP® OFFSHORE CABLES

GAALSHIP® MEDIUM IEEE type E BS

90°C, 5 kV - 8 kV - 15 kV, three power-cores + (grounding-core on request), 100% & 133% insulation level, armoured and sheathed (BS)

ELETTROTEK KABEL® GAALSHIP® MEDIUM IEEE type E BS

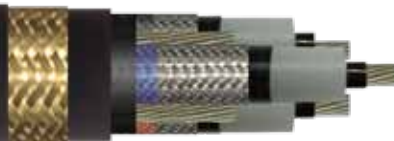

15 kV, 100% insulation level

Part no.	No. of cores x cross section n x AWG/MCM	Ø under armour ca. inches ± 10%	Outer-Ø ca. inches ± 10%	Cable weight approx. lbs/MFt.
25040T7K030A02	3x2 (+1x6)	2,157	2,443	3697
25040T7K030A01	3x1 (+1x4)	2,239	2,524	4045
25040T7K030A1C	3x1/0 (+1x4)	2,335	2,62	4477
25040T7K030A2C	3x2/0 (+1x4)	2,461	2,81	5242
25040T7K030A3C	3x3/0 (+1x3)	2,559	2,91	5764
25040T7K030A4C	3x4/0 (+1x3)	2,691	3,041	6513
25040T7K030APC	3x262 (+1x3)	2,539	3,152	7348
25040T7K030AQC	3x313 (+1x2)	2,881	3,287	8184
25040T7K030ANC	3x373 (+1x2)	3,021	3,365	8856
25040T7K030ARC	3x444 (+1x1)	3,183	3,527	9983
25040T7K030AOC	3x535 (+1x1)	3,357	3,701	11285

15 kV, 133% insulation level

Part no.	No. of cores x cross section n x AWG/MCM	Ø under armour ca. inches ± 10%	Outer-Ø ca. inches ± 10%	Cable weight approx. lbs/MFt.
25041T7K030A02	3x2 (+1x6)	2,334	2,619	4137
25041T7K030A01	3x1 (+1x4)	2,416	2,701	4515
25041T7K030A1C	3x1/0 (+1x4)	2,512	2,861	5150
25041T7K030A2C	3x2/0 (+1x4)	2,637	2,987	5748
25041T7K030A3C	3x3/0 (+1x3)	2,842	3,192	6640
25041T7K030A4C	3x4/0 (+1x3)	2,976	3,325	7430
25041T7K030APC	3x262 (+1x3)	2,989	3,34	7831
25041T7K030AQC	3x313 (+1x2)	3,091	3,394	8529
25041T7K030ANC	3x373 (+1x2)	3,204	3,548	9510
25041T7K030ARC	3x444 (+1x1)	3,347	3,69	10560
25041T7K030AOC	3x535 (+1x1)	3,521	3,865	11910

Other dimensions and colors available on request.
25 kV version available on request.

GAALSHIP® MEDIUM IEEE type E TS

90°C, 8 kV - 15 kV, three power-cores + three earth-cores, 133% insulation level, armoured and sheathed (TS)

ELETTROTEK KABEL® GAALSHIP® MEDIUM-VFD IEEE type E TS

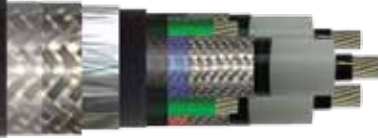

Construction:

Conductor:	flexible tinned copper conductor, acc to IEEE 1580 table 11
Semi-conductive layer:	semi-conductive tape + extruded thermosetting semi-conductive material acc. to UL 1309, IEEE 1580 and UL 1072
Insulation:	extruded thermosetting EPR compound 90°C acc. to UL 1309 Type E, IEEE 1580 Type E and UL 1072
Semi-conductive layer:	semi-conductive tape acc. to UL 1309, IEEE 1580 and UL 1072
Screen:	nylon tape with overall tinned copper braiding acc. to UL 1309, IEEE 1580 and UL 1072 each nylon tape is colored for easy phase identification (black, blue, red)
Grounding conductor:	soft annealed tinned flexible stranded copper acc. to IEEE 1580 table 11, sized acc. to UL 1072 table 23.2
Cores color:	green
Inner sheath:	thermosetting compound acc. to UL 1309/CSA 245, IEEE 1580 and UL 1072
Armouring/Screen:	tinned copper braid + Aluminium/polyester tape acc. to IEEE 1580, UL 1307/CSA 245
Outer sheath:	black (RAL 9005) thermosetting compound acc. to UL 1309 IEEE 1580 and UL 1072 on request different sheath colors to distinguish the different levels of voltage: 8 kV = orange outer sheath 15 kV = red outer sheath

Resistance:



Fire retardant acc. to:
IEC 60332-3-22,
IEEE 1202

Technical data:

Nominal voltage:	8 kV 15 kV
Temperature range:	-40°C up to +90°C
Min. bending radius:	8 x d

Features:

Oil abrasion, chemical, moisture, cold resistant
Sunlight resistant
Det Norske Veritas (DNV)
Lloyd's register of shipping (LRS)
American Bureau of Shipping (ABS)
UL listed as Marine Shipboard Cables



LISTED



Available on stock CABLE GLANDS:
see page 404 up to 416 of catalogue.

GAALSHIP® OFFSHORE CABLES

GAALSHIP® MEDIUM IEEE type E TS

90°C, 8 kV - 15 kV, three power-cores + three earth-cores, 133% insulation level, armoured and sheathed (TS)

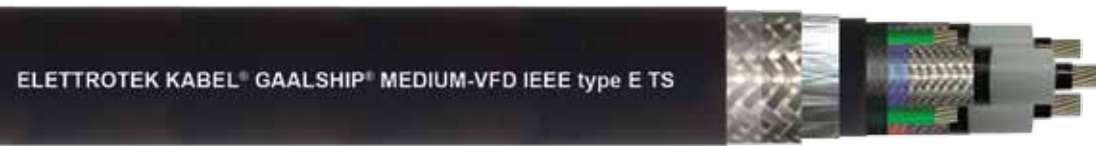

8 kV, 133% insulation level

Part no.	No. of cores x cross section n x AWG/MCM	Outer-Ø ca. inches ± 10%	Cable weight approx. lbs/Mft.
25050P7K037A06	3x6+3G10	1,687	1634
25050P7K037A04	3x4+3G10	1,868	2074
25050P7K037A02	3x2+3G10	2,071	2625
25050P7K037A01	3x1+3G8	2,161	3022
25050P7K037A1C	3x1/0+3G8	2,262	3373
25050P7K037A2C	3x2/0+3G8	2,381	3826
25050P7K037A3C	3x3/0+3G6	2,489	4411
25050P7K037A4C	3x4/0+3G6	2,631	5093
25050P7K037APC	3x262+3G6	3,857	5993
25050P7K037AQC	3x313+3G6	3,03	6867
25050P7K037ANC	3x373+3G4	3,164	7810
25050P7K037ARC	3x444+3G4	3,319	8855
25050P7K037AOC	3x535+3G4	3,492	9905
25050P7K037ASC	3x646+3G..	-	10580

15 kV, 133% insulation level

Part no.	No. of cores x cross section n x AWG/MCM	Outer-Ø ca. inches ± 10%	Cable weight approx. lbs/Mft.
25050T7K037A02	3x2+3G10	2,403	2959
25050T7K037A01	3x1+3G8	2,468	3231
25050T7K037A1C	3x1/0+3G8	2,596	4090
25050T7K037A2C	3x2/0+3G8	2,714	4615
25050T7K037A3C	3x3/0+3G6	2,875	5306
25050T7K037A4C	3x4/0+3G6	3,028	6131
25050T7K037APC	3x262+3G6	3,260	7074
25050T7K037AQC	3x313+3G6	3,363	7787
25050T7K037ANC	3x373+3G4	3,5	8703
25050T7K037ARC	3x444+3G4	3,652	9912

Other dimensions and colors available on request.
25 kV version available on request.

* diameters and weights are in reference to armouring/screen + outer sheath construction.

GAALSHIP® INSTRUMENTATION IEEE type P

Extremely flexible, I 10°C, 0,6/1 kV, individual-overall screened pairs/triples, unarmoured

ELETTROTEK KABEL® GAALSHIP® INSTRUMENTATION IEEE type P



Construction:

Conductor:	flexible tinned copper conductor, acc to IEEE 1580 table 11
Insulation:	special cross-linked polyolefin acc. to IEEE type P, and UL 1309/CSA 245 type X110
Cores color:	pairs: black-white triples: black-white-red
Stranding:	Each pair/triple is twisted with a bare tinned drain wire
Individual Screen:	Aluminium/polyester tape
Stranding:	laying up in pairs/triples
Overall screen:	Aluminium/polyester tape
Outer sheath:	black (RAL 9005) thermosetting compound acc. to UL 1309/CSA 245 and IEEE 1580

Resistance:



Fire retardant acc. to:
IEC 60332-3-22,
IEEE 1202

Technical data:

Nominal voltage:	0,6/1 kV
Temperature range:	-40°C up to +110°C
Capacitance (nF/MFt)*:	
AWG 18:	28
AWG 16:	32
AWG 14 (pairs):	37
inductance (mH/MFt)*:	
AWG 18:	0,22
AWG 16:	0,20
AWG 14 (pairs):	0,19
Resistance (Ohms/MFt)*:	
AWG 18:	7,21 (at 20°C)
AWG 16:	4,52 (at 20°C)
AWG 14 (pairs):	2,85 (at 20°C)

* Pairs/triples values

Features:

Oil abrasion, chemical, moisture, cold resistant
Sunlight resistant
low toxic and corrosive gases emissions
highest ampacity ratings:
ABS 100°C, DNV 95°C, Transport Canada 95°C
NVE 95/16996, FAL
Transport Canada
Det Norske Veritas (DNV)
Lloyd's register of shipping (LRS)
American Bureau of Shipping (ABS)
UL listed as Marine Shipboard Cables
United States Coast Guard November 2, 1987
CSA listed as Marine shipboard cables



LISTED

on request blue outer sheath or with stripe for intrinsically safe circuits



Available on stock CABLE GLANDS:
see page 404 up to 416 of catalogue.

GAALSHIP® INSTRUMENTATION IEEE type P

Extremely flexible, I 10°C, 0,6/1 kV, individual-overall screened pairs/triples, unarmoured

ELETTROTEK KABEL® GAALSHIP® INSTRUMENTATION IEEE type P



Part no.	No. of pairs/triples x AWG	Outer-Ø ca. inches ± 10%	Cable weight approx. lbs/MFt.
22010G7X012A18	1 x 2 x 18	0,336	63
22010G7X022A18	2 x 2 x 18	0,551	131
22010G7X032A18	3 x 2 x 18	0,581	163
22010G7X042A18	4 x 2 x 18	0,630	195
22010G7X052A18	5 x 2 x 18	0,685	243
22010G7X072A18	7 x 2 x 18	0,742	340
22010G7X082A18	8 x 2 x 18	0,8	388
22010G7X102A18	10 x 2 x 18	0,976	495
22010G7X122A18	12 x 2 x 18	1,011	581
22010G7X162A18	16 x 2 x 18	1,121	748
22010G7X182A18	18 x 2 x 18	1,181	824
22010G7X242A18	24 x 2 x 18	1,382	1069
22010G7X012A16	1 x 2 x 16	0,356	77
22010G7X022A16	2 x 2 x 16	0,565	160
22010G7X032A16	3 x 2 x 16	0,617	200
22010G7X042A16	4 x 2 x 16	0,671	239
22010G7X052A16	5 x 2 x 16	0,73	297
22010G7X072A16	7 x 2 x 16	0,792	416
22010G7X082A16	8 x 2 x 16	0,896	475
22010G7X102A16	10 x 2 x 16	1,047	606
22010G7X122A16	12 x 2 x 16	1,081	711
22010G7X162A16	16 x 2 x 16	1,207	948
22010G7X182A16	18 x 2 x 16	1,265	1100
22010G7X202A16	20 x 2 x 16	1,327	1215
22010G7X242A16	24 x 2 x 16	1,482	1510
22010G7X012A14	1 x 2 x 14	0,386	97
22010G7X022A14	2 x 2 x 14	0,621	202
22010G7X032A14	3 x 2 x 14	0,658	251
22010G7X042A14	4 x 2 x 14	0,721	301
22010G7X052A14	5 x 2 x 14	0,791	374
22010G7X072A14	7 x 2 x 14	0,905	524
22010G7X082A14	8 x 2 x 14	0,979	498
22010G7X102A14	10 x 2 x 14	1,148	747
22010G7X122A14	12 x 2 x 14	1,186	896
22010G7X013A18	1 x 3 x 18	0,354	75
22010G7X023A18	2 x 3 x 18	0,649	183
22010G7X033A18	3 x 3 x 18	0,688	190
22010G7X043A18	4 x 3 x 18	0,755	281
22010G7X053A18	5 x 3 x 18	0,871	286
22010G7X073A18	7 x 3x 18	0,947	409
22010G7X083A18	8 x 3 x 18	1,026	515
22010G7X123A18	12 x 3 x 18	1,244	766
22010G7X013A16	1 x 3 x 16	0,376	86
22010G7X033A16	3 x 3 x 16	0,735	218
22010G7X043A16	4 x 3 x 16	0,807	410
22010G7X063A16	6 x 3 x 16	1,012	630
22010G7X073A16	7 x 3 x 16	1,012	710
22010G7X083A16	8 x 3 x 16	1,09	729

Other dimensions and colors available on request.

GAALSHIP® INSTRUMENTATION IEEE type P B

Extremely flexible, I 10°C, 0,6/1 kV, individual-overall screened pairs/triples, armoured (B)



Construction:

Conductor:	flexible tinned copper conductor, acc to IEEE 1580 table 11
Insulation:	special cross-linked polyolefin acc. to IEEE type P, and UL 1309/CSA 245 type X110
Cores color:	pairs: black-white triples: black-white-red
Stranding:	each pair/triple is twisted with a bare tinned drain wire
Individual Screen:	aluminium/polyester tape
Stranding:	laying up in pairs/triples
Overall screen:	aluminium/polyester tape
Inner sheath:	thermosetting compound acc. to UL 1309/CSA 245 and IEEE 1580
Armouring:	basket weave bronze wire, acc. to IEEE 1580 and UL 1309/CSA 245 on request tinned copper

Technical data:

Nominal voltage:	0,6/1 kV
Temperature range:	-40°C up to +110°C
Capacitance (nF/Mft)*:	
AWG 18:	28
AWG 16:	32
AWG 14 (pairs):	37
inductance (mH/Mft)*:	
AWG 18:	0,22
AWG 16:	0,20
AWG 14 (pairs):	0,19
Resistance (Ohms/Mft)*:	
AWG 18:	7,21 (at 20°C)
AWG 16:	4,52 (at 20°C)
AWG 14 (pairs):	2,85 (at 20°C)

* Pairs/triples values

Resistance:



Fire retardant acc. to:
IEC 60332-3-22,
IEEE 1202

Features:

Oil abrasion, chemical, moisture, cold resistant
Sunlight resistant
low toxic and corrosive gases emissions
highest ampacity ratings:
ABS 100°C, DNV 95°C, Transport Canada 95°C
NVE 95/16996, FAL
Transport Canada
Det Norske Veritas (DNV)
Lloyd's register of shipping (LRS)
American Bureau of Shipping (ABS)
UL listed as Marine Shipboard Cables
United States Coast Guard November 2, 1987
CSA listed as Marine shipboard cables



LISTED

on request blue outer sheath or with stripe for intrinsically safe circuits

on request tinned copper wire braid armouring



Available on stock CABLE GLANDS:
see page 404 up to 416 of catalogue.

GAALSHIP® INSTRUMENTATION IEEE type P B

Extremely flexible, I 10°C, 0,6/1 kV, individual-overall screened pairs/triples, armoured (B)



Part no.	No. of pairs/triples x AWG	Ø under armour ca. inches ± 10%	Outer-Ø ca. inches ± 10%	Cable weight approx. lbs/MFt.
22020G7X012A18	1 x 2 x 18	0,336	0,386	123
22020G7X022A18	2 x 2 x 18	0,551	0,601	204
22020G7X032A18	3 x 2 x 18	0,581	0,631	265
22020G7X042A18	4 x 2 x 18	0,630	0,68	317
22020G7X052A18	5 x 2 x 18	0,685	0,735	395
22020G7X072A18	7 x 2 x 18	0,742	0,792	457
22020G7X082A18	8 x 2 x 18	0,8	0,85	521
22020G7X102A18	10 x 2 x 18	0,976	1,026	699
22020G7X122A18	12 x 2 x 18	1,011	1,061	780
22020G7X162A18	16 x 2 x 18	1,121	1,171	833
22020G7X182A18	18 x 2 x 18	1,181	1,231	1050
22020G7X242A18	24 x 2 x 18	1,382	1,432	1151
22020G7X012A16	1 x 2 x 16	0,356	0,406	120
22020G7X022A16	2 x 2 x 16	0,565	0,615	249
22020G7X032A16	3 x 2 x 16	0,617	0,667	311
22020G7X042A16	4 x 2 x 16	0,671	0,721	389
22020G7X052A16	5 x 2 x 16	0,73	0,78	483
22020G7X072A16	7 x 2 x 16	0,792	0,842	559
22020G7X082A16	8 x 2 x 16	0,896	0,946	638
22020G7X102A16	10 x 2 x 16	1,047	1,097	787
22020G7X122A16	12 x 2 x 16	1,081	1,131	923
22020G7X162A16	16 x 2 x 16	1,207	1,257	1231
22020G7X182A16	18 x 2 x 16	1,265	1,315	1260
22020G7X202A16	20 x 2 x 16	1,327	1,377	1476
22020G7X242A16	24 x 2 x 16	1,482	1,532	1625
22020G7X012A14	1 x 2 x 14	0,386	0,436	151
22020G7X022A14	2 x 2 x 14	0,621	0,671	315
22020G7X032A14	3 x 2 x 14	0,658	0,708	391
22020G7X042A14	4 x 2 x 14	0,721	0,771	469
22020G7X052A14	5 x 2 x 14	0,791	0,841	608
22020G7X072A14	7 x 2 x 14	0,905	0,955	704
22020G7X082A14	8 x 2 x 14	0,979	1,029	803
22020G7X102A14	10 x 2 x 14	1,148	1,198	1003
22020G7X122A14	12 x 2 x 14	1,186	1,236	1203
22020G7X013A18	1 x 3 x 18	0,354	0,404	144
22020G7X023A18	2 x 3 x 18	0,649	0,699	290
22020G7X033A18	3 x 3 x 18	0,688	0,738	305
22020G7X043A18	4 x 3 x 18	0,755	0,805	408
22020G7X053A18	5 x 3 x 18	0,871	0,921	419
22020G7X073A18	7 x 3x 18	0,947	0,997	565
22020G7X083A18	8 x 3 x 18	1,026	1,076	680
22020G7X123A18	12 x 3 x 18	1,244	1,294	965
22020G7X013A16	1 x 3 x 16	0,376	0,426	155
22020G7X033A16	3 x 3 x 16	0,735	0,785	338
22020G7X043A16	4 x 3 x 16	0,807	0,857	530
22020G7X063A16	6 x 3 x 16	1,012	1,062	750
22020G7X073A16	7 x 3 x 16	1,012	1,062	835
22020G7X083A16	8 x 3 x 16	1,09	1,14	876

Other dimensions and colors available on request.

GAALSHIP® INSTRUMENTATION IEEE type P BS

Extremely flexible, 110°C, 0,6/1 kV, individual-overall screened pairs/triples, armoured and sheathed (BS)

ELETTROTEK KABEL® GAALSHIP® INSTRUMENTATION IEEE type P BS

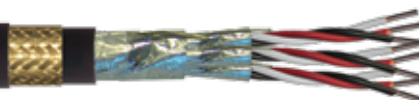

Construction:

Conductor:	flexible tinned copper conductor, acc to IEEE 1580 table 11
Insulation:	special cross-linked polyolefin acc. to IEEE type P, and UL 1309/CSA 245 type X110
Cores color:	pairs: black-white triples: black-white-red
Stranding:	Each pair/triple is twisted with a bare tinned drain wire
Individual Screen:	aluminium/polyester tape
Stranding:	laying up in pairs/triples
Overall screen:	aluminium/polyester tape
Inner sheath:	thermosetting compound acc. to UL 1309/CSA 245 and IEEE 1580
Armouring:	basket weave bronze wire, acc. to IEEE 1580 and UL 1309/CSA 245 on request tinned copper
Outer sheath:	black (RAL 9005) thermosetting compound acc. to UL 1309/CSA 245 and IEEE 1580

Resistance:



Fire retardant acc. to:
IEC 60332-3-22,
IEEE 1202

Technical data:

Nominal voltage:	0,6/1 kV
Temperature range:	-40°C up to +110°C
Capacitance (nF/MFt)*:	
AWG 18:	28
AWG 16:	32
AWG 14 (pairs):	37
inductance (mH/MFt)*:	
AWG 18:	0,22
AWG 16:	0,20
AWG 14 (pairs):	0,19
Resistance (Ohms/MFt)*:	
AWG 18:	7,21 (at 20°C)
AWG 16:	4,52 (at 20°C)
AWG 14 (pairs):	2,85,19 (at 20°C)

* Pairs/triples values

Features:

Oil abrasion, chemical, moisture, cold resistant
Sunlight resistant
low toxic and corrosive gases emissions
highest ampacity ratings:
ABS 100°C, DNV 95°C, Transport Canada 95°C
NVE 95/16996, FAL
Transport Canada
Det Norske Veritas (DNV)
Lloyd's register of shipping (LRS)
American Bureau of Shipping (ABS)
UL listed as Marine Shipboard Cables
United States Coast Guard November 2, 1987
CSA listed as Marine shipboard cables



LISTED

on request blue outer sheath or with stripe
for intrinsically safe circuits

on request tinned copper wire braid armouring



Available on stock CABLE GLANDS:
see page 404 up to 416 of catalogue.

GAALSHIP® OFFSHORE CABLES

GAALSHIP® INSTRUMENTATION IEEE type P BS

Extremely flexible, 110°C, 0,6/1 kV, individual-overall screened pairs/triples, armoured and sheathed (BS)

ELETTROTEK KABEL® GAALSHIP® INSTRUMENTATION IEEE type P BS

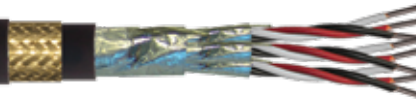

Part no.	No. of pairs/triples x AWG	Ø under armour ca. inches ± 10%	Outer-Ø ca. inches ± 10%	Cable weight approx. lbs/MFt.
22030G7X012A18	1 x 2 x 18	0,336	0,486	176
22030G7X022A18	2 x 2 x 18	0,551	0,732	335
22030G7X032A18	3 x 2 x 18	0,581	0,762	343
22030G7X042A18	4 x 2 x 18	0,630	0,801	410
22030G7X052A18	5 x 2 x 18	0,685	0,9	511
22030G7X072A18	7 x 2 x 18	0,742	0,957	575
22030G7X082A18	8 x 2 x 18	0,8	1,015	752
22030G7X102A18	10 x 2 x 18	0,976	1,199	874
22030G7X122A18	12 x 2 x 18	1,011	1,234	982
22030G7X162A18	16 x 2 x 18	1,121	1,344	1182
22030G7X182A18	18 x 2 x 18	1,181	1,404	1300
22030G7X242A18	24 x 2 x 18	1,382	1,605	1720
22030G7X012A16	1 x 2 x 16	0,356	0,507	203
22030G7X022A16	2 x 2 x 16	0,565	0,751	377
22030G7X032A16	3 x 2 x 16	0,617	0,785	410
22030G7X042A16	4 x 2 x 16	0,671	0,886	569
22030G7X052A16	5 x 2 x 16	0,73	0,945	609
22030G7X072A16	7 x 2 x 16	0,792	1,007	703
22030G7X082A16	8 x 2 x 16	0,896	1,119	803
22030G7X102A16	10 x 2 x 16	1,047	1,27	1098
22030G7X122A16	12 x 2 x 16	1,081	1,304	1138
22030G7X162A16	16 x 2 x 16	1,207	1,422	1517
22030G7X182A16	18 x 2 x 16	1,265	1,488	1570
22030G7X202A16	20 x 2 x 16	1,327	1,552	1894
22030G7X242A16	24 x 2 x 16	1,482	1,767	2065
22030G7X012A14	1 x 2 x 14	0,386	0,537	199
22030G7X022A14	2 x 2 x 14	0,621	0,802	481
22030G7X032A14	3 x 2 x 14	0,658	0,881	515
22030G7X042A14	4 x 2 x 14	0,721	0,944	633
22030G7X052A14	5 x 2 x 14	0,791	1,013	787
22030G7X072A14	7 x 2 x 14	0,905	1,128	886
22030G7X082A14	8 x 2 x 14	0,979	1,202	1011
22030G7X102A14	10 x 2 x 14	1,148	1,371	1196
22030G7X122A14	12 x 2 x 14	1,186	1,409	1434
22030G7X013A18	1 x 3 x 18	0,354	0,504	199
22030G7X023A18	2 x 3 x 18	0,649	0,872	380
22030G7X033A18	3 x 3 x 18	0,688	0,911	393
22030G7X043A18	4 x 3 x 18	0,755	0,978	551
22030G7X053A18	5 x 3 x 18	0,871	1,094	561
22030G7X073A18	7 x 3x 18	0,947	1,170	724
22030G7X083A18	8 x 3 x 18	1,026	1,249	870
22030G7X123A18	12 x 3 x 18	1,244	1,467	1195
22030G7X013A16	1 x 3 x 16	0,376	0,558	213
22030G7X033A16	3 x 3 x 16	0,735	0,958	466
22030G7X043A16	4 x 3 x 16	0,807	1,03	700
22030G7X063A16	6 x 3 x 16	1,012	1,235	955
22030G7X073A16	7 x 3 x 16	1,012	1,235	1050
22030G7X083A16	8 x 3 x 16	1,09	1,33	1103

Other dimensions and colors available on request.

GAALSHIP® OFFSHORE IEEE TECHNICAL DATA

Current carrying capacity values:

110°C (Free Air)	Acc. to IEEE Std. 835-1994 for isolated cables in free air with full sun, 2 ft/s air movement, and a 45°C ambient.
110°C	Acc. to IEEE Std. 45 with a 45°C ambient and arranged in a single bank per hanger. For those instances where cable must be double banked, the 110°C ampacities should be multiplied by 0,8.
100°C	Acc. to IEEE Std. 45 with a 45°C ambient and arranged in a single bank per hanger. For those instances where cable must be double banked, the 100°C ampacities should be multiplied by 0,8.
95°C	Acc. to Table 4/3C.10 of the 1997 ABS MODU rules and a 45°C ambient.
Current carrying capacity for four conductor cables are based on one conductor not acting as a normal current-carrying conductor (e.g., grounded neutral or grounding conductor)	
For free air ratings, the IEEE Std. 45 numbers can be divided by 0.85	

Min. bending radius:

	Unarmored	Armored	Armored & Sheathed
IEEE 45	6 x D	8 x D	8 x D
IEC 92	≤ 1" (25mm) 4 x Diameter ≥ 1" (25mm) 6X Diameter	6 x D	8 x D
TRANSPORT CANADA	<1" (25mm) 4X Diameter >1" (25mm) 6X Diameter	6 x D	6 x D

Strand make-up:

Cross section AWG/Kcmil	Cross section mm ²	Approx. cross section IEEE 45 Std.	Number of strands	Individual strand Ø (inches)	Conductor (uninsulated) Ø (inches)
18	0,96	2	19	0,01	0,049
16	1,32	3	19	0,0117	0,059
14	2,08	4	19	0,0147	0,074
12	3,29	6	19	0,0185	0,093
10	5,23	10	37	0,0167	0,113
8	7,57	16	37	0,0201	0,136
6	12,49	26	61	0,0201	0,175
4	21,11	41	133	0,0177	0,258
2	33,51	66	133	0,0223	0,324
1	42,79	83	209	0,0201	0,361
1/0	54,45	106	266	0,0201	0,407
2/0	70,01	133	342	0,0201	0,461
3/0	85,57	168	418	0,0201	0,51
4/0	108,91	212	532	0,0201	0,575
262	132,25	262	646	0,0201	0,654
313	159,06	313	777	0,0201	0,72
373	189,36	373	925	0,0201	0,785
444	227,23	444	1110	0,0201	0,86
535	272,68	535	1332	0,0201	0,941
646	325,7	646	1591	0,0201	1,029
777	393,87	777	1924	0,0201	1,132
1111	561,94	1111	2745	0,0201	1,354

MANUFACTURE'S COMPARATIVE TABLE

ELETTROTEKKABEL®	PRYSMIAN	NEXANS
GAALSHIP MARINE CABLES:		
GAALSHIP® HF 1000	HFX-U 0,6/1 kV	MPRX® 0,6/1 kV
GAALSHIP® HF 1000 A	HFX-A/Cu 0,6/1 kV	MPRXCX® 0,6/1 kV
GAALSHIP® HF 1000 FR	HFX-U FR 0,6/1 kV	MPRX® 331 0,6/1
GAALSHIP® HF 1000 A FR	HFX-A/Cu-FR 0,6/1 kV	MPRXCX® 331 0,6/1 kV
GAALSHIP® HF 250 OS	HFX-OSU 150/250V	TX® (C) 250V
GAALSHIP® HF 250 OS FR	HFX-OSU FR 150/250V	
GAALSHIP® HF 250 A	-	TCX® (C) 250V
GAALSHIP® HF 250 A FR	-	-
GAALSHIP® HF 250 OSA	HFX-OSA 150/250V	-
GAALSHIP® HF 250 OSA FR	HFX-OSA FR 150/250V	-
GAALSHIP® HF 250 IS	-	TX® (I) 250V
GAALSHIP® HF 250 ISA	-	TCX® (I) 250V
GAALSHIP® HF 250 ISOS	HFX-ISOSU 150/250V	-
GAALSHIP® HF 250 ISOS FR	HFX-ISOSU FR 150/250V	-
GAALSHIP® HF 250 ISOSA	HFX-ISOSA/Cu 150/250V	-
GAALSHIP® HF 250 ISOSA FR	HFX-ISOSA FR 150/250V	-
GAALSHIP® SFH... 1,8 kV to 12/20 kV	MV-FHFX from 1,8/3 kv up to 12/20 kV - one core	-
GAALSHIP® MFH... 1,8 kV to 12/20 kV	MV-FHFX from 1,8/3 kv up to 12/20 kV - three cores	MPRXCX® 6/10 kV or MEPRXCX® 8.7/15 kV
GAALSHIP OFFSHORE CABLES:		
NEK NORMATIVES:		
GAALSHIP® RU	TEOF RU P18 or P18+MUD 0,6/1 kv	RU 600/1000V P18
GAALSHIP® RFOU	TEOF RFOU P1 or P1/P8 0,6/1 kv	RFOU 600/1000V P1 or P1/P8
GAALSHIP® BU	TEOF BU P17 or P17+MUD 0,6/1 kv	BU 600/1000V P17
GAALSHIP® BFOU	TEOF BFOU P5 or P5/P12+MUD 0,6/1 kv	BFOU 600/1000V P5 or P5/P12
GAALSHIP® UX	TEOF UX P15 0,6/1 kv	UX 600/1000V P15
GAALSHIP® VFD F-RFOU	TEOFVFD F-RFOU or F-RFOU+MUD 0,6/1 kv	RFOU-EMC 600/1000V or RFOU-EMC 600/1000V MR
GAALSHIP® RFOU 3,6/6 kV up to 12/20 kV	TEOF RFOU P2...or P2.../...P21 from 3,6/6 kv up to 12/20 kV	POWER CABLE (RFOU) or POWER CABLE (RFOU/B) from 3,6 up to 12/20 kV
GAALSHIP® RU(i)	TEOF RU(i) S11 or S11+MUD 150/250V	-
GAALSHIP® RFOU(i)	TEOF RFOU(i) S1 or S1/S5 150/250V	RFOU(I) 250V S1 or S1/S5
GAALSHIP® RU(c)	TEOF RU(c) S12 or S12+MUD 150/250V	-
GAALSHIP® RFOU(c)	TEOF RFOU(c) S2 or S2/S6 150/250V	RFOU(C) 250V S2 or S2/S6
GAALSHIP® BU(i)	TEOF BU(i) S13 or S13+MUD 150/250V	-
GAALSHIP® BFOU(i)	TEOF BFOU(i) S3 or S3/S7 150/250V	BFOU(I) 250V P5 or P5/P12
GAALSHIP® BU(c)	TEOF BU(c) S14 or S14+MUD 150/250V	-
GAALSHIP® BFOU(c)	TEOF BFOU(c) S4 or S4/S8 150/250V	BFOU(C) 250V S4 or S4/S8
BS NORMATIVES:		
GAALSHIP® (RU 0,6/1 kV)	TEOF SW4 or SW2 0,6/1 kV	-
GAALSHIP® G (RFCU 0,6/1 kV)	TEOF G SW4 or SW2 0,6/1 kV	-
GAALSHIP® FR	TEOF FR SW4(FO)(or F1) or SW2 FO(orF1) 0,6/1 kV	-
GAALSHIP® G FR (BFCU 0,6/1 kV)	TEOF G FR SW4(FO)(or F1) or SW2 FO(orF1) 0,6/1 kV	-
GAALSHIP® G MEDIUM	TEOF G SW4 or SW2 from 3,8/6,6 kV up to 8,7/15 kV	-
GAALSHIP® TI	TEOFTI SW4(i) or SW2(i) 150/250V	-
GAALSHIP® TO	TEOFTO SW4(c) or SW2(c) 150/250V	-
GAALSHIP® TIG (RFCU(i) 250 V)	TEOFTIG SW4(i) or SW2(i) 150/250V	-
GAALSHIP® TOG (RFCU(c) 250 V)	TEOFTOG SW4(c) or SW2(c) 150/250V	-
GAALSHIP® TIG FR (BFCU(i) 250 V)	TEOFTIG FR SW4 FO(i)(orF1) or SW2 FO(i)(orF1) 150/250V	-
GAALSHIP® TOG FR (BFCU(c) 250 V)	TEOFTOG FR SW4 FO(c)(orF1) or SW2 FO(c)(orF1) 150/250V	-
IEC NORMATIVES:		
GAALSHIP® LD RE4(O)A(CuSn)M1 or FE4(O)A(CuSn)M1 0,6/1 kV	TEOF LD RE4(O)A(CuSn)M1 or FE4(O)A(CuSn)M1 0,6/1 kV	-
GAALSHIP® LD RE4XOHM1A(CuSn)M or FE4XOHM1A(CuSn)M1 150/250V	TEOF LD RE4XOHM1A(CuSn)M or FE4XOHM1A(CuSn)M1 150/250V	-

CABLE GLANDS



CABLE GLANDS

STANDARD GLAND

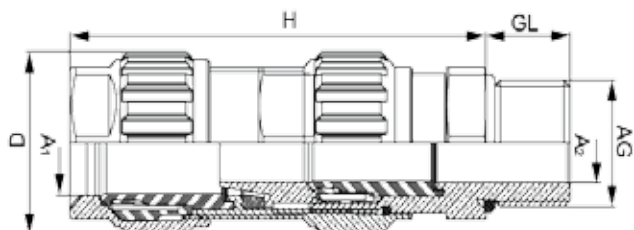
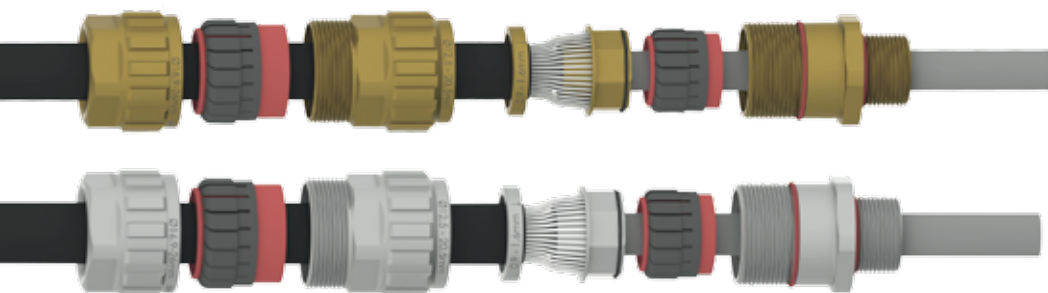

Construction:

Material:	brass, nickel-plated brass or stainless steel on request
Seals / O-Rings:	silicone, VMQ
Clamping insert:	PA 6
Armour:	Metallic Armour or Screen
Temperature Range:	- 60° C / 105° C (-76 °F / 221 °F)
Protection:	IP 66, 67 and 68 (5 bar)
Certificate:	IECEx BVS 10.0078 X BVS 10 ATEX E 062 X CSA 2557737

Features:

Dual seal on the inner and outer sheath of the cable

Armour acceptance range from 0 – 2,5 mm

Exceptional clamping range

Innovative “Interlocking Armour Cone”

Zero torsion on cable cores and armour

Fast and easy pre-assembly by hand by the use of profile material with maximum grip

According to the latest IECEx and ATEX standards

Ex-e / Ex-d / Ex-ta

Zones 1, 2, 20, 21, 22

II 2G Ex d e IIC Gb / II 1D Ex ta IIIC Da

Equipment Protection Level GbDa

IP 66, 67 and 68 (5 bar)

Halogen - and phosphorous-free

Silicone Seals and O-Ring are standard



ATEX Ex

CABLE GLANDS

STANDARD GLAND

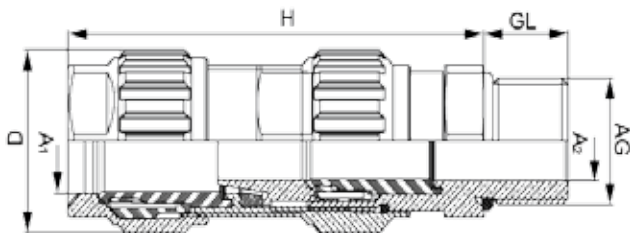
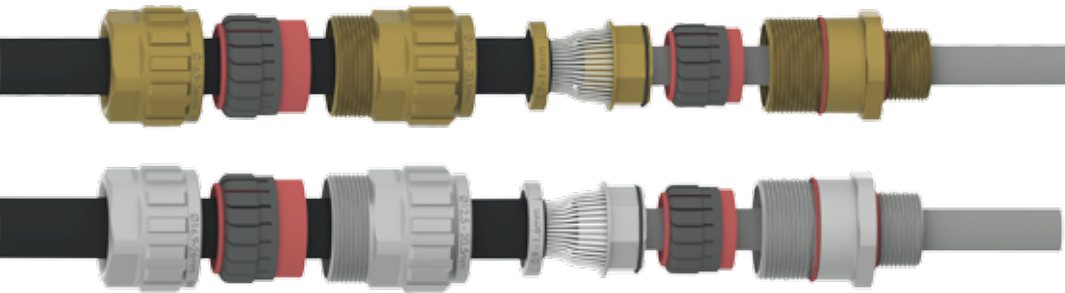

Metric Brass:

Armour \varnothing mm

Part no.	Gland Size	AG	wrench mm	D mm	H max.	GL mm	A1 mm	A2 mm	Clamping ring 1	Clamping ring 2	Ring3 optional
HWCG400116..50	20 - 1	M 16 x 1,5	22	27	69,5	16	6 - 12	3 - 8,1	0 - 0,7	0,7 - 1,25	-
HWCG400120..50	20 - 1	M 20 x 1,5	22	27	69,5	16	6 - 12	3 - 8,1	0 - 0,7	0,7 - 1,25	-
HWCG400120..51	20 - 2	M 20 x 1,5	24	29	74,3	16	9 - 16	6 - 12	0 - 0,7	0,7 - 1,25	-
HWCG400120..52	20 - 3	M 20 x 1,5	30	35	80,5	16	12,5 - 20,5	9 - 14	0 - 0,7	0,7 - 1,4	-
HWCG400125..51	20 - 3	M 25 x 1,5	30	35	80,5	16	12,5 - 20,5	9 - 14	0 - 0,7	0,7 - 1,4	-
HWCG400125..50	25	M 25 x 1,5	36	42	91	16	16,9 - 26	12,5 - 20,5	0 - 0,7	0,9 - 1,6	0,7 - 1,4
HWCG400132..50	32	M 32 x 1,5	46	52	96	16	22 - 23	16,9 - 26	0 - 0,7	1,3 - 2,0	0,7 - 1,4
HWCG400140..50	40	M 40 x 1,5	55	64	107	16	28 - 41	22 - 33	0 - 0,7	1,3 - 2,0	0,7 - 1,4
HWCG400150..50	50	M 50 x 1,5	65	73	131,5	16	36 - 52,6	28,9 - 44,4	0 - 1,0	1,5 - 2,5	1,0 - 2,0
HWCG400163..50	63	M 63 x 1,5	80	90	144,5	16	46 - 65,3	39,9 - 56,3	0 - 1,0	1,5 - 2,5	1,0 - 2,0
HWCG400175..50	75	M 75 x 1,5	95	107	154	16	57 - 78	50,5 - 68,2	0 - 1,0	1,5 - 2,5	1,0 - 2,0

NPT Brass:

Armour \varnothing mm

Part no.	Gland Size	AG	wrench mm	D mm	H max.	GL mm	A1 mm	A2 mm	Clamping ring 1	Clamping ring 2	Ring3 optional
HWCG400138..70	20 - 1	NPT 3/8"	22	27	69,5	16	6 - 12	3 - 8,1	0 - 0,7	0,7 - 1,25	-
HWCG400112..70	20 - 2	NPT 1/2"	24	29	74,3	20	9 - 16	6 - 12	0 - 0,7	0,7 - 1,25	-
HWCG400112..71	20 - 3	NPT 1/2"	30	35	80,5	20	12,5 - 20,5	9 - 14	0 - 0,7	0,7 - 1,4	-
HWCG400134..70	25	NPT 3/4"	36	42	91	20,5	16,9 - 26	12,5 - 20,5	0 - 0,7	0,9 - 1,6	0,7 - 1,4
HWCG400110..70	32	NPT 1"	46	52	96	25	22 - 23	16,9 - 26	0 - 0,7	1,3 - 2,0	0,7 - 1,4
HWCG400154..70	40	NPT 1 1/4"	55	64	107	26	28 - 41	22 - 33	0 - 0,7	1,3 - 2,0	0,7 - 1,4
HWCG400164..70	40	NPT 1 1/2"	55	64	107	26,5	28 - 41	22 - 33	0 - 0,7	1,3 - 2,0	0,7 - 1,4
HWCG400120..70	50	NPT 2"	65	73	131,5	27	36 - 52,6	28,9 - 44,4	0 - 1,0	1,5 - 2,5	1,0 - 2,0
HWCG400152..70	63	NPT 2 1/2"	80	90	144,5	40	46 - 65,3	39,9 - 56,3	0 - 1,0	1,5 - 2,5	1,0 - 2,0
HWCG400130..70	75	NPT 3"	95	107	154	41,5	57 - 78	50,5 - 68,2	0 - 1,0	1,5 - 2,5	1,0 - 2,0

* The two point inside the part number refers to the different materials in which cable glands can be produced:

00: brass

02: stainless steel (on request)

03: nickel plated brass

CABLE GLANDS

BARRIER GLAND

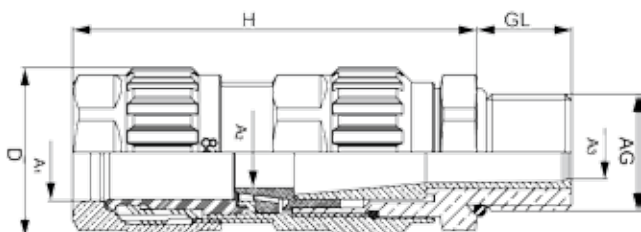
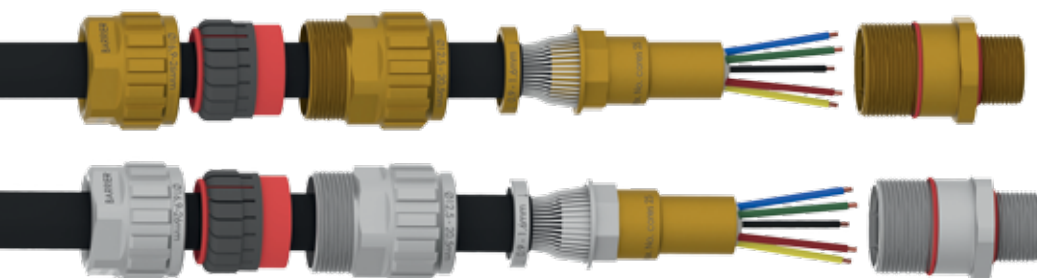

Construction:

Material:	brass, nickel-plated brass or stainless steel on request
Seals / O-Rings:	silicone, VMQ
Compound:	Epoxy-Putty
Clamping insert:	PA 6
Armour:	Metallic Armour or Screen
Temperature Range:	- 60° C / 85° C (-76 °F / 185 °F)
Protection:	IP 66, 67 and 68 (5 bar)
Certificate:	IECEx SIR 11.0044X Sira 11 ATEX 1110X CSA 2557737

Features:

According to the latest IECEx and ATEX standards

Ex-e / Ex-d / Ex-ta

Zones 1, 2, 20, 21, 22

I M2 Ex d e I Mb iiC Gb / Ex ta IIIC Da

Equipment Protection Level MbGbDa

IP 66, 67 and 68 (5 bar)

Halogen - and phosphorous-free

Silicone Seals and O-Ring are standard



CABLE GLANDS

BARRIER GLAND

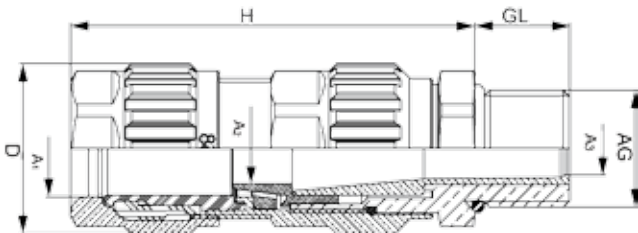
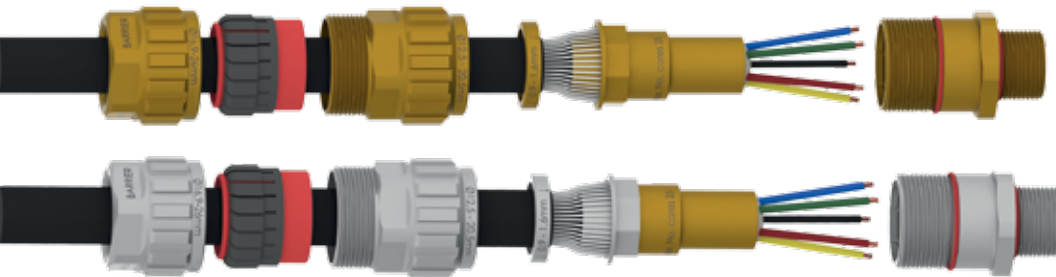

Metric Brass:

Armour \varnothing mm

Part no.	Gland Size	AG	wrench mm	D mm	H max.	GL mm	AI mm	A2 max. inner sheath mm	A3 max. over cores mm	Clamping ring 1	Clamping ring 2	Ring3 optional
HWCG400216..50	20 - 1	M 16 x 1,5	22	27	69,5	16	6 - 12	8,2	7,9	8	0 - 0,7	0,7 - 1,25
HWCG400220..50	20 - 1	M 20 x 1,5	22	27	69,5	16	6 - 12	8,2	7,9	8	0 - 0,7	0,7 - 1,25
HWCG400220..51	20 - 2	M 20 x 1,5	24	29	74,3	16	9 - 16	12	8,8	10	0 - 0,7	0,7 - 1,25
HWCG400220..52	20 - 3	M 20 x 1,5	30	35	80,5	16	12,5 - 20,5	14	11,5	15	0 - 0,7	0,7 - 1,4
HWCG400225..51	20 - 3	M 25 x 1,5	30	35	80,5	16	12,5 - 20,5	14	11,5	15	0 - 0,7	0,7 - 1,4
HWCG400225..50	25	M 25 x 1,5	36	42	91	16	16,9 - 26	20	16,4	25	0 - 0,7	0,9 - 1,6
HWCG400232..50	32	M 32 x 1,5	46	52	96	16	22 - 23	26	21,4	45	0 - 0,7	1,3 - 2,0
HWCG400240..50	40	M 40 x 1,5	55	64	107	16	28 - 41	33,2	27,6	70	0 - 0,7	1,3 - 2,0
HWCG400250..50	50	M 50 x 1,5	65	73	131,5	16	36 - 52,6	44,2	37,5	85	0 - 1,0	1,5 - 2,5
HWCG400263..50	63	M 63 x 1,5	80	90	144,5	16	46 - 65,3	56,2	47,3	120	0 - 1,0	1,5 - 2,5
HWCG400275..50	75	M 75 x 1,5	95	107	154	16	57 - 78	68,2	58	150	0 - 1,0	1,5 - 2,5

NPT Brass:

Armour \varnothing mm

Part no.	Gland Size	AG	wrench mm	D mm	H max.	GL mm	AI mm	A2 max. inner sheath mm	A3 max. over cores mm	Clamping ring 1	Clamping ring 2	Ring3 optional
HWCG400238..70	20 - 1	NPT 3/8"	22	27	64	16	6 - 12	8,2	7,9	8	0 - 0,7	0,7 - 1,25
HWCG400212..70	20 - 2	NPT 1/2"	24	29	68	20	9 - 16	12	8,8	10	0 - 0,7	0,7 - 1,25
HWCG400212..71	20 - 3	NPT 1/2"	30	35	73	20	12,5 - 20,5	14	11,5	15	0 - 0,7	0,7 - 1,4
HWCG400234..70	25	NPT 3/4"	36	42	81,3	20,5	16,9 - 26	20	16,4	25	0 - 0,7	0,9 - 1,6
HWCG400210..70	32	NPT 1"	46	52	85,5	25	22 - 23	26	21,4	45	0 - 0,7	1,3 - 2,0
HWCG400254..70	40	NPT 1 1/4"	55	64	94,4	26	28 - 41	33,2	27,6	70	0 - 0,7	1,3 - 2,0
HWCG400264..70	40	NPT 1 1/2"	55	64	94,4	26,5	28 - 41	33,2	27,6	70	0 - 0,7	1,3 - 2,0
HWCG400220..70	50	NPT 2"	65	73	116,3	27	36 - 52,6	44,2	37,5	85	0 - 1,0	1,5 - 2,5
HWCG400252..70	63	NPT 2 1/2"	80	90	127,6	40	46 - 65,3	56,2	47,3	120	0 - 1,0	1,5 - 2,5
HWCG400230..70	75	NPT 3"	95	107	136,5	41,5	57 - 78	68,2	58	150	0 - 1,0	1,5 - 2,5

* The two point inside the part number refers to the different materials in which cable glands can be produced:

- 00: brass
- 02: stainless steel (on request)
- 03: nickel plated brass

CABLE GLANDS

A2F GLAND

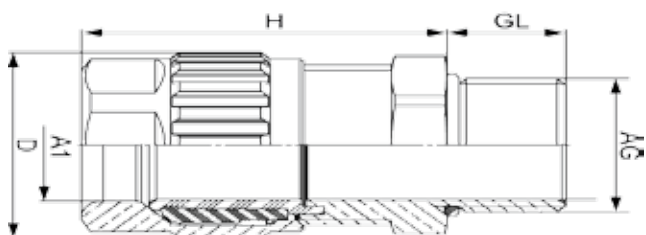
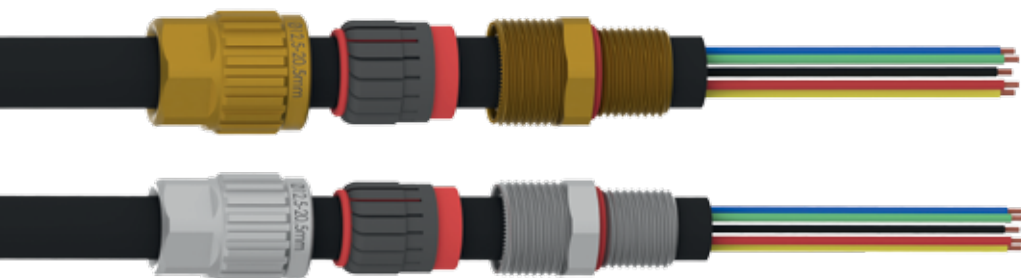

Construction:

Material:	brass, nickel-plated brass or stainless steel on request
Seals / O-Rings:	silicone, VMQ
Clamping insert:	PA 6
Temperature Range:	- 60° C / 105° C (-76 °F / 221 °F)
Protection:	IP 66, 67 and 68 (5 bar)
Certificate:	IECEX DEK 12.0039 X DEKRA 12 ATEX 0139 X CSA 2557737

Features:

According to the latest IECEx and ATEX standards

Ex-e / Ex-d / Ex-ta

Zones 1, 2, 20, 21, 22

II 2G Ex d e IIC Gb / II 1D Ex ta IIIC Da

Equipment Protection Level MbGbDa

IP 66, 67 and 68 (5 bar)

Halogen - and phosphorous-free

Silicone Seals and O-Ring are standard



CABLE GLANDS

A2F GLAND

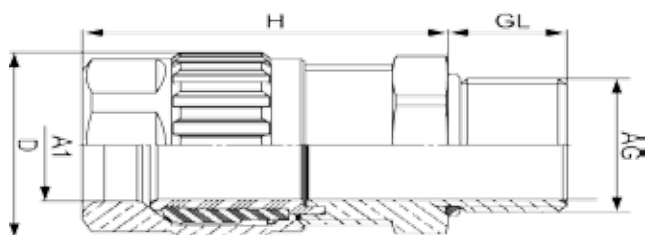
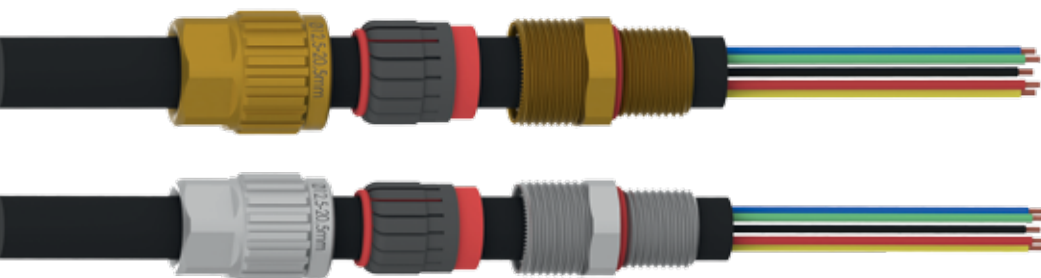

Metric Brass:

Part no.	Gland Size	AG	wrench mm	D mm	H max.	GL mm	AI mm
HWCG400316..50	20 - 1	M 16 x 1,5	22	27	35,6	16	6 - 12
HWCG400320..50	20 - 1	M 20 x 1,5	22	27	35,6	16	6 - 12
HWCG400320..51	20 - 2	M 20 x 1,5	24	29	39,7	16	9 - 16
HWCG400325..50	20 - 3	M 25 x 1,5	30	35	47,5	16	12,5 - 20,5
HWCG400332..50	25	M 32 x 1,5	36	42	47,8	16	16,9 - 26
HWCG400340..50	32	M 40 x 1,5	46	52	51,1	16	22 - 23
HWCG400350..50	40	M 50 x 1,5	55	64	56,8	16	28 - 41
HWCG400363..50	50	M 63 x 1,5	65	73	65,4	16	40 - 52,6
HWCG400375..50	63	M 75 x 1,5	80	90	70,3	16	51 - 65,3
HWCG400390..50	75	M 90 x 2	95	107	76,2	20	62 - 78

NPT Brass:

Part no.	Gland Size	AG	wrench mm	D mm	H max.	GL mm	AI mm
HWCG400338..70	20 - 1	NPT 3/8"	22	27	35,6	16	6 - 12
HWCG400312..70	20 - 1	NPT 1/2"	22 / 24	27	35,6	20	6 - 12
HWCG400312..71	20 - 2	NPT 1/2"	24	29	39,7	20	9 - 16
HWCG400334..70	20 - 3	NPT 3/4"	30	35	47,5	20,5	12,5 - 20,5
HWCG400310..70	25	NPT 1"	36	42	47,8	25	16,9 - 26
HWCG400354..70	32	NPT 1 1/4"	46	52	51,1	26	22 - 23
HWCG400364..70	40	NPT 1 1/2"	55	64	56,8	26,5	28 - 41
HWCG400320..70	50	NPT 2"	65	73	65,4	27	40 - 52,6
HWCG400352..70	63	NPT 2 1/2"	80	90	70,3	40	51 - 61
HWCG400330..70	75	NPT 3"	95	107	76,2	41,5	62 - 78

* The two point inside the part number refers to the different materials in which cable glands can be produced:

00: brass

02: stainless steel (on request)

03: nickel plated brass

CABLE GLANDS

MZ GLAND

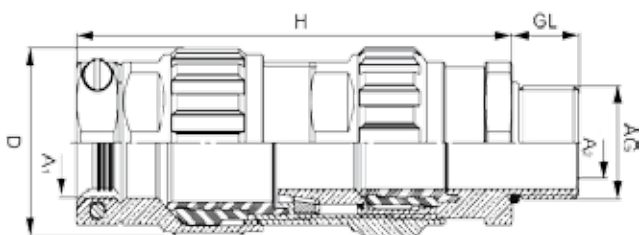
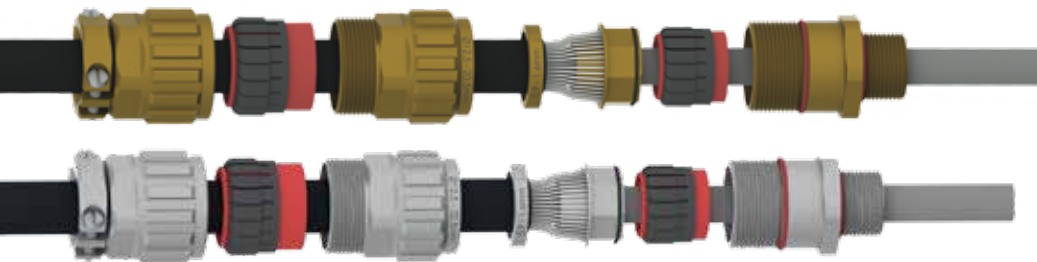

Construction:

Material:	brass, nickel-plated brass or stainless steel on request
Seals / O-Rings:	silicone, VMQ
Clamping insert:	PA 6
Armour:	Metallic Armour or Screen
Temperature Range:	- 60° C / 105° C (-76 °F / 221 °F)
Protection:	IP 66, 67 and 68 (5 bar)
Certificate:	IECEX BVS 10.0078 X BVS 10 ATEX E 062 X

Features:

- Dual seal on the inner and outer sheath of the cable**
- Armour acceptance range from 0 – 2,5 mm**
- Exceptional clamping range**
- Innovative “Interlocking Armour Cone”**
- Zero torsion on cable cores and armour**
- Fast and easy pre-assembly by hand by the use of profile material with maximum grip**
- With additional cable clamp (MZ)**
- According to the latest IECEX and ATEX standards**
- Ex-e / Ex-d / Ex-ta**
- Zones 1, 2, 20, 21, 22**
- II 2G Ex d e IIC Gb / II 1D Ex ta IIIC Da**
- Equipment Protection Level GbDa**
- IP 66, 67 and 68 (5 bar)**
- Halogen - and phosphorous-free**
- Silicone Seals and O-Ring are standard**



CABLE GLANDS

MZ GLAND

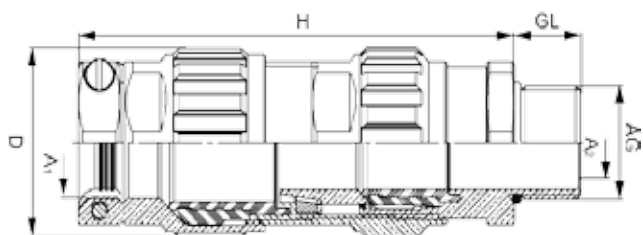
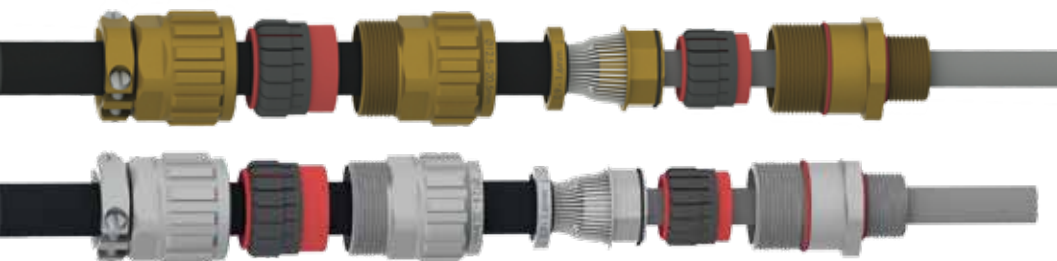

Metric Brass:

Armour \varnothing mm

Part no.	Gland Size	AG	wrench mm	D mm	H max.	GL mm	A1 mm	A2 mm	Clamping ring 1	Clamping ring 2	Ring3 optional
HWCG400416..50	20 - 1	M 16 x 1,5	22	27	79	16	6 - 11	3 - 8,1	0 - 0,7	0,7 - 1,25	-
HWCG400420..50	20 - 1	M 20 x 1,5	22	27	79	16	6 - 11	3 - 8,1	0 - 0,7	0,7 - 1,25	-
HWCG400420..51	20 - 2	M 20 x 1,5	24	29	83,8	16	9 - 13	6 - 12	0 - 0,7	0,7 - 1,25	-
HWCG400420..52	20 - 3	M 20 x 1,5	30	35	91,5	16	12,5 - 17,5	9 - 14	0 - 0,7	0,7 - 1,4	-
HWCG400425..51	20 - 3	M 25 x 1,5	30	35	91,5	16	12,5 - 17,5	9 - 14	0 - 0,7	0,7 - 1,4	-
HWCG400425..50	25	M 25 x 1,5	36	42	105,7	16	16,9 - 24	12,5 - 20,5	0 - 0,7	0,9 - 1,6	0,7 - 1,4
HWCG400432..50	32	M 32 x 1,5	46	52	107	16	22 - 23,5	16,9 - 26	0 - 0,7	1,3 - 2,0	0,7 - 1,4
HWCG400440..50	40	M 40 x 1,5	55	64	120	16	28 - 39,5	22 - 33	0 - 0,7	1,3 - 2,0	0,7 - 1,4
HWCG400450..50	50	M 50 x 1,5	65	73	144,5	16	36 - 49	28,9 - 44,4	0 - 1,0	1,5 - 2,5	1,0 - 2,0
HWCG400463..50	63	M 63 x 1,5	80	90	157,5	16	46 - 64	39,9 - 56,3	0 - 1,0	1,5 - 2,5	1,0 - 2,0
HWCG400475..50	75	M 75 x 1,5	95	107	167	16	57 - 78	50,5 - 68,2	0 - 1,0	1,5 - 2,5	1,0 - 2,0

NPT Brass:

Armour \varnothing mm

Part no.	Gland Size	AG	wrench mm	D mm	H max.	GL mm	A1 mm	A2 mm	Clamping ring 1	Clamping ring 2	Ring3 optional
HWCG400438..70	20 - 1	NPT 3/8"	22	27	79	16	6 - 11	3 - 8,1	0 - 0,7	0,7 - 1,25	-
HWCG400412..70	20 - 2	NPT 1/2"	24	29	83,8	20	9 - 13	6 - 12	0 - 0,7	0,7 - 1,25	-
HWCG400412..71	20 - 3	NPT 1/2"	30	35	91,5	20	12,5 - 17,5	9 - 14	0 - 0,7	0,7 - 1,4	-
HWCG400434..70	25	NPT 3/4"	36	42	105,7	20,5	16,9 - 24	12,5 - 20,5	0 - 0,7	0,9 - 1,6	0,7 - 1,4
HWCG400410..70	32	NPT 1"	46	52	107	25	22 - 32,5	16,9 - 26	0 - 0,7	1,3 - 2,0	0,7 - 1,4
HWCG400454..70	40	NPT 1 1/4"	55	64	120	26	28 - 39,5	22 - 33	0 - 0,7	1,3 - 2,0	0,7 - 1,4
HWCG400464..70	40	NPT 1 1/2"	55	64	120	26,5	28 - 39,5	22 - 33	0 - 0,7	1,3 - 2,0	0,7 - 1,4
HWCG400420..70	50	NPT 2"	65	73	144,5	27	36 - 49	28,9 - 44,4	0 - 1,0	1,5 - 2,5	1,0 - 2,0
HWCG400452..70	63	NPT 2 1/2"	80	90	157,5	40	46 - 64	39,9 - 56,3	0 - 1,0	1,5 - 2,5	1,0 - 2,0
HWCG400430..70	75	NPT 3"	95	107	167	41,5	57 - 78	50,5 - 68,2	0 - 1,0	1,5 - 2,5	1,0 - 2,0

* The two point inside the part number refers to the different materials in which cable glands can be produced:

00: brass

02: stainless steel (on request)

03: nickel plated brass

CABLE GLANDS

ACCESSORIES

Earth Tag Brass:

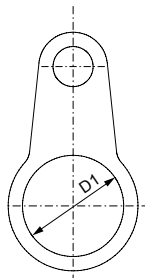

Part no.	Metric	Part no.	NPT
HWET4550160050	M16	HWET4550120070	1/2"
HWET4550200050	M20	HWET4550340070	3/4"
HWET4550250050	M25	HWET4550100070	1"
HWET4550320050	M32	HWET4550540070	1 1/4"
HWET4550400050	M40	HWET4550640070	1 1/2"
HWET4550500050	M50	HWET4550200070	2"
HWET4550630050	M63	HWET4550520070	2 1/2"
HWET4550750050	M75	HWET4550300070	3"

Red Fiber Washer:



Part no.	Metric	Part no.	NPT
HWFW4560160050	M16	HWFW4560120070	1/2"
HWFW4560200050	M20	HWFW4560340070	3/4"
HWFW4560250050	M25	HWFW4560100070	1"
HWFW4560320050	M32	HWFW4560540070	1 1/4"
HWFW4560400050	M40	HWFW4560640070	1 1/2"
HWFW4560500050	M50	HWFW4560200070	2"
HWFW4560630050	M63	HWFW4560520070	2 1/2"
HWFW4560750050	M75	HWFW4560300070	3"

PVC shroud



Part no. PVC shroud	Size	Part no. LSF shroud	Size
HWPS4570200050	20 - 1	HWLS4570200050	20 - 1
HWPS4570200051	20 - 2	HWLS4570200051	20 - 2
HWPS4570200052	20 - 3	HWLS4570200052	20 - 3
HWPS4570250050	25	HWLS4570250050	25
HWPS4570320050	32	HWLS4570320050	32
HWPS4570400050	40	HWLS4570400050	40
HWPS4570500050	50	HWLS4570500050	50
HWPS4570630050	63	HWLS4570630050	63
HWPS4570750050	75	HWLS4570750050	75

CABLE GLANDS

ACCESSORIES

Serrated Washer INOX:

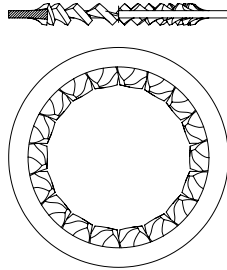

Part no.	Metric	Part no.	NPT
HWSW4580160050	M16	HWSW4580120070	1/2"
HWSW4580200050	M20	HWSW4580340070	3/4"
HWSW4580250050	M25	HWSW4580100070	1"
HWSW4580320050	M32	HWSW4580540070	1 1/4"
HWSW4580400050	M40	HWSW4580640070	1 1/2"
HWSW4580500050	M50	HWSW4580200070	2"
HWSW4580630050	M63	HWSW4580520070	2 1/2"
HWSW4580750050	M75	HWSW4580300070	3"

Locknut nickel plated brass:

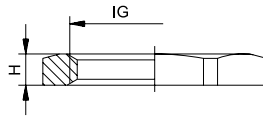

Part no.	IG	H	wrench mm
HWLN4590160050	M 16 x 1,5	2,8	19
HWLN4590200050	M 20 x 1,5	3	23
HWLN4590250050	M 25 x 1,5	3,5	29
HWLN4590320050	M 32 x 1,5	4	36
HWLN4590400050	M 40 x 1,5	4,5	45
HWLN4590500050	M 50 x 1,5	5,5	55
HWLN4590630050	M 63 x 1,5	6	70
HWLN4590750050	M 75 x 1,5	8	85

CABLE GLANDS TECHNICAL DATA

Condition for an explosion

So that an explosion can occur, three conditions must be fulfilled:

1. Fuel
2. Oxygen
3. Source of ignition

If one removes one of these three conditions, an explosion cannot occur.

Potentially Explosive Atmosphere

A potentially explosive atmosphere is understood to be a mixture of a combustible material and oxygen. Oxygen is generally present as a component of air. Combustible materials can be e.g.: gases, fluids, vapours, mist or dusts. If the proportion of oxygen falls below a certain value dependent on the material, known as the oxygen limit concentration, then this mixture cannot be ignited.

Zones IEC/CENELEC/ATEX

GAS

- | | |
|---------------|---|
| Zone 0 | relates to areas in which a potentially explosive atmosphere consisting of a mixture of air and gases, vapours or mist exists continuously, for long periods or frequently |
| Zone 1 | relates to areas in which it can be considered that a potentially explosive atmosphere of gases, vapours or mist occurs occasionally |
| Zone 2 | relates to areas in which it is unlikely that a potentially explosive atmosphere of gases, vapours or mist might occur, but if it does occur then in all probability only seldom and for a short period |

DUST

- | | |
|----------------|--|
| Zone 20 | relates to areas in which a potentially explosive atmosphere consisting of a mixture of dust and air exists continuously, for long periods or frequently |
| Zone 21 | relates to areas in which it can be considered that a potentially explosive atmosphere of a mixture of dust and air occurs occasionally |
| Zone 22 | note the difference between conductive and non-conductive dust!) relates to areas in which it is unlikely that a potentially explosive atmosphere of suspended dust might occur, but if it does occur then in all probability only seldom and for a short period |

Zones IEC/CENELEC/ATEX

Group I Mining

M1 high degree of safety EPL Ma

M2 high degree of safety EPL Mb

Group II non Mining

1 very high degree of safety: Gas (Zone 0, 1, 2) EPL Ga, Dust (Zone 20, 21, 22) EPL Da

2 high degree of safety: Gas (Zone 1, 2) EPL Ga, Dust (Zone 21, 22) EPL Da

3 normal degree of safety: Gas (Zone 2) EPL Ga, Dust (Zone 22) EPL Da

CABLE GLANDS

CABLE GLANDS TECHNICAL DATA

Zones IEC/CENELEC/ATEX

GAS

IIA Propane

IIB Ethylene

IIC Hydrogene

DUST

IIA combustible dust

IIB non-conductive dust

IIC conductive dust

Temperature Classes

Temperature Class	Highest permissible surface temperature of the operating facility	Ignition temperature of combustible materials
T1	450 °C	> 450 °C
T2	300 °C	> 300 °C < 450 °C
T3	200 °C	> 200 °C < 300 °C
T4	135 °C	> 135 °C < 200 °C
T5	100 °C	> 100 °C < 200 °C
T6	85 °C	> 85 °C < 100 °C

Protection Concepts

Electrical

Intrinsic safety	Ex-ia	IEC 60079-11/EN 60079-11	Zone 0,1,2	Limit the energy
Intrinsic safety	Ex-ib	IEC 60079-11/EN 60079-11	Zone 1,2	
Intrinsic safety	Ex-ic	IEC 60079-11/EN 60079-11	Zone 2	
Increased safety	Ex-e	IEC 60079-7/EN 60079-7	Zone 1,2	No arcs, sparks or hot surfaces, IP54 or better.
Flameproof enclosure	Ex-d	IEC 60079-1/EN 60079-1	Zone 1,2	Contain the explosion use a flamepath.

Dust

Enclosure	Ex-t	IEC 60079-31/EN 60079-31	Zone 20,21,22	Dust tight enclosure IP6X
-----------	------	--------------------------	---------------	---------------------------

CABLE GLANDS

CABLE GLANDS TECHNICAL DATA

International Protection, EN 60529										
1 Code		2 Code								
Protection against human access to hazardous parts	Protection of equipment against penetration of solid foreign objects	penetration of water								
		non protected	Protection against drip water (or dripping water)	Protected against vertically falling water	Water sprayed at an angle up to 60° on either side of the vertical	Water splashed from any direction shall have no harmful effects	Water splashed from any direction shall have no harmful effects	Water splashed from any direction shall have no harmful effects	protection against temporary submersion	protection against permanent submersion
		IP x0	IP x1	IP x2	IP x3	IP x4	IP x5	IP x6	IP x7	IP x8
non protected	non protected	IP 0x	IP 00							
Protected against access to hazardous parts with the back of the hand	Protected against solid foreign objects larger in diameter than 50 mm	IP 1x	IP 10	IP 11	IP 12					
Protected against access to hazardous parts with a finger	Protected against solid foreign object larger in diameter than 12,5 mm	IP 2x	IP 20	IP 21	IP 22	IP 23				
Protected against access to hazardous parts with a tool larger in diameter than 25 mm	Protected against solid foreign objects larger in diameter than 2,5 mm	IP 3x	IP 30	IP 31	IP 32	IP 33	IP 34			
Protected against access to hazardous parts with a wire larger in diameter than 1,0 mm	Protected against solid foreign objects larger in diameter than 1 mm	IP 4x	IP 40	IP 41	IP 42	IP 43	IP 44			
Protected against access to hazardous parts with a wire larger in diameter than 1,0 mm	Prevents penetration of dust sufficient to cause damage inside the equipment.	IP 5x	IP 50				IP 54	IP 55		
Protected against access to hazardous parts with a wire larger in diameter than 1,0 mm	Dust proof	IP 6x	IP 60					IP 65	IP 66	IP 67 IP 68

OUR Cable Glands Standards

IEC 60079-0:2011 IEC 60079-1:2007-4 IEC 60079-7:2006-07 IEC 60079-31:2008

EN 60079-0:2012 EN 60079-1:2007 EN 60079-7:2007 EN 60079-31:2009

EN 60529

TECHNICAL DATA

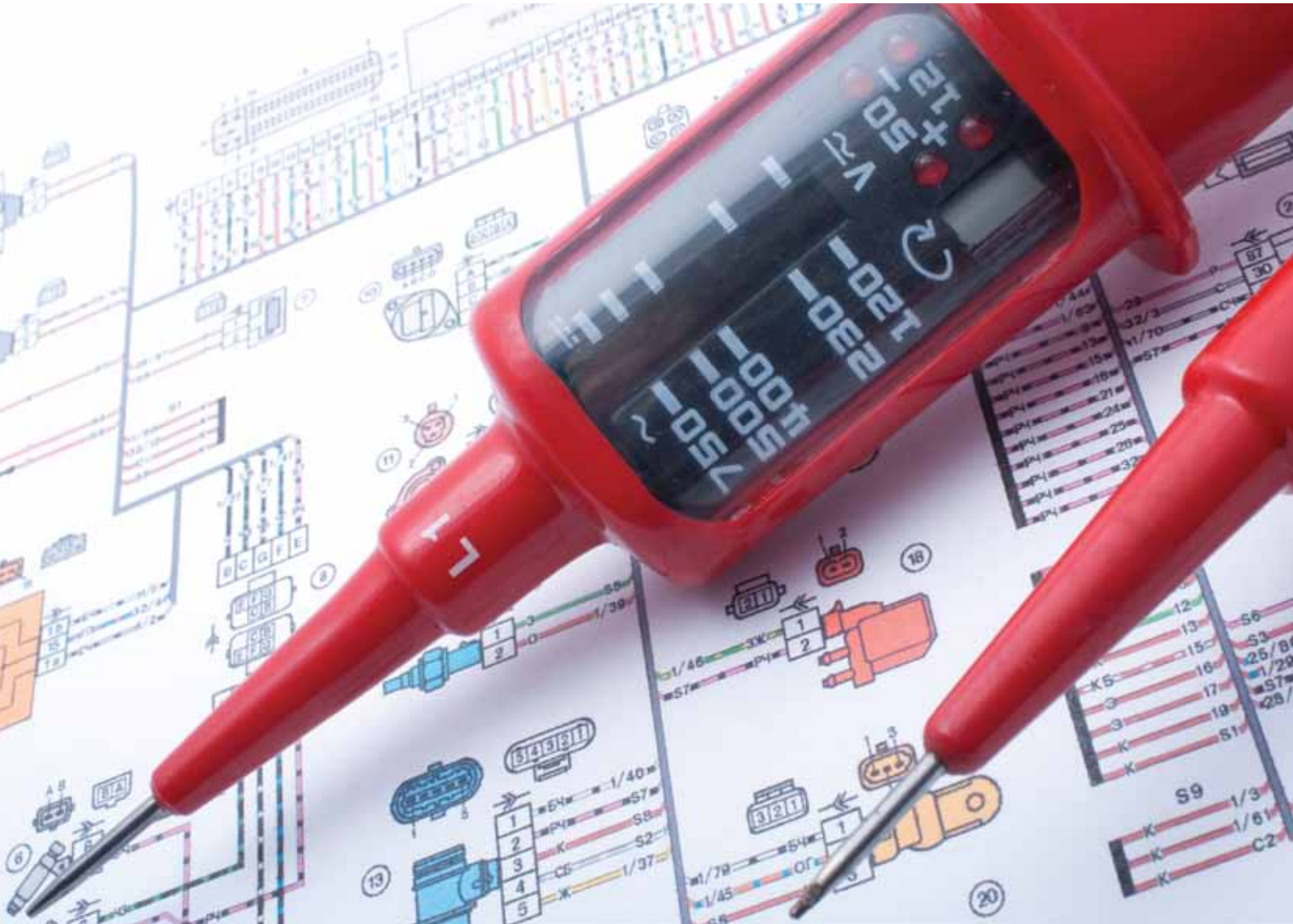

TECHNICAL DATA INDEX

RESISTANCE SYMBOLS LEGEND	419
COSTRUCTION CODE	420/422
STRAND MAKE-UP.....	423/425
CONVERSION FROM AWG.....	426
GENERAL CONVERSION.....	427
COLOUR CODE.....	428/448
LOW VOLTAGE CURRENT CARRYING CAPACITY	449/450
LOW VOLTAGE PHASE SPLITTING - RESISTANCE AND REACTANCE	451
LOW VOLTAGE RESISTANCE AND REACTANCE.....	452
LOW VOLTAGE RESISTANCE AND REACTANCE - VOLTAGE DROP	453
LOW VOLTAGE -VOLTAGE DROP.....	454
LOW VOLTAGE - SHORT-CIRCUIT	455/456
MEDIUM VOLTAGE CURRENT CARRYING CAPACITY.....	457
MEDIUM VOLTAGE CORRECTION FACTORS.....	458
MEDIUM VOLTAGE CORRECTION FACTORS AND PHASE SPLITTING	459
MEDIUM VOLTAGE RESISTANCE.....	460
MEDIUM VOLTAGE REACTANCE.....	461
MEDIUM VOLTAGE REACTANCE - SHORT CIRCUIT CURRENT CAPACITY.....	462
MINIMUM BENDING RADIUS.....	463
FLAMABILITY TEST	464/470
HANDLING AND INSTALLATION	471/476
CAPACITY OF KTG POOL DRUMS	477
DRUM SIZE AND DRUM TYPE	478

RESISTANCE SYMBOLS LEGEND



Fire performance
Fire resistant

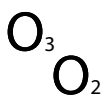

Ozone-Oxygene resistance



mud resistant



Flame retardant and
self-extinguishing

F

flourine resistance



microbe resistant



Halogen-free



weather/atmospheric
resistance



Railway network stability



Smoke density/
low smoke emission



impact-crushing
resistance



Corrosiveness of
combustion gases



Mechanical resistance



Chem. resistance



water and cold
resistance



Abrasion
notch resistant



high temperature/
heat resistance



UV resistant/
Sunlight resistant



electro magnetic
resistance



Ozone resistance



ageing resistance



Oil resistance



water resistant

COSTRUCTION CODE

ITALIAN SYSTEM In accordance with UNEL 3501 I-2000	EUROPEAN SYSTEM In accordance with CEI 20-27/CENELEC HD 361
Conductor flexibility rating	Reference standards
A Aluminium conductor	H In conformity with harmonized standards
F Stranded flexible round conductor	A Suit to IEC standard
FF Stranded very flexible round conductor	N not suit to IEC standard
R Stranded rigid (compacted) conductor	Rated voltage Uo/U
U Solid conductor	03 300/300V
Type and quality of insulation	05 300/500V
E Thermoplastic polyethylene compound	07 450/750V
E4 Cross-linked polyethylene compound at 85°C	1 600/1000V
G Natural and/or synthetic rubber compound at 60°C	Sheath insulating material
G4 Silicone rubber compound at 180°C	B Ethylene propylene rubber at operating temperature of 60°C
G7 High module ethylene propylene rubber compound at 90°C	G Ethylene-vinylacetylene
G8 Ethylene propylene rubber compound at 85°C also for cables without protecting covering	J Glass fibre
G9 Cross-linked elastomeric compound with low emission of smoke and toxic and corrosive gases at 90°C, also for cables without protecting covering	M Mineral
G10 Cross-linked elastomeric compound with low emission of smoke and toxic and corrosive gases at 90°C	N Polychloroprene
G19 Cross-linked elastomeric compound with low emission of smoke and toxic and corrosive gases at 90°C	N2 Special polychloroprene compound for welding machines cables
G20 Cross-linked insulating compound with low emission of smoke and toxic and corrosive gases at 90°C	N4 Chloro-sulphurine or chlorinated polyethylene
M9 Thermoplastic compound with low emission of smoke and toxic and corrosive gases at 70°C	N8 Special water resistant polychloroprene compound
R Polyvinyl chloride compound at 70°C, T11 and T12 type	Q Polyurethane
R2 Polyvinyl chloride compound at 70°C, R2 type	Q4 Polyamide
R4 Polyamide resin compound	R Ethylene propylene rubber and equivalent synthetic elastomer at operating temperature of 60°C
R5 Fluorocarbon resin compound	S Silicone rubber
R5F Fluorocarbon resin compound - tetrafluorine ethylene-esafuorine propylene copolymer (FEP)	T Textile braid (impregnated if necessary) on the cores
R5M Fluorocarbon resin compound - tetrafluorine ethylene-perfluorine methylmethylether copolymer (MFA)	T6 Textile braid (impregnated if necessary) on each cores of multicore cables
R5P R5P Fluorocarbon resin compound - tetrafluorine ethylene-pperfluorine propylmethylether copolymer (PFA)	V Polyvinyl chloride (or PVC)
R7 Polyvinyl chloride compound at 90°C, T13 type	V2 PVC compound at operating temperature of 90°C
T4 Tissue painted with oils and resins	V3 PVC compound for cables installed at low temperatures
V Glass tissue (impregnated if necessary)	V4 Cross-linked PVC
T One or more glass/mica tapes or closed braid of glass	V5 Special oil resistant PVC compound
Screen and concentric conductors	Z Cross-linked polyolefin-based compound with low emission of smoke and toxic and corrosive gases in case of combustion
O Concentric copper conductor	Z1 Thermoplastic compound with low emission of smoke and toxic and corrosive gases in case of combustion
H Metallized paper or carbone-copy or aluminium tape	Metallic covering (concentric conductors and shields)
H1 Copper tape, flat wire or wire screen	C Copper concentric conductor
H2 Copper braid screen	C4 Copper braid screen collectively applied on the cores
H3 Double copper braid screen	A7 Aluminium screen
H4 Longitudinal corrugated steel tape	C5 Copper braid screen individually applied on the cores
H5 Longitudinal laminated aluminium tape	C7 Copper tape, hot wire, or wire screen
Armour (metallic covering)	Armour
A Smooth aluminum sheath or metallic braid shielding	Z2 Steel wire armouring
F Steel wire armouring	Z3 Flat steel wire armouring
H5 Longitudinal laminated aluminium tape armouring	Z4 Steel tape armouring
L Lead alloy sheath	Z5 Steel wire braid
N Steel tape armouring	Shape and special design
P Lead sheath	H "Strippable" flat cables
Z Steel flat wires	H2 "Not strippable" flat cables
Sheath (non metallic covering)	H6 Flat cable with 3 cores or more, in conformity with HD 359 or EN 50214
E Thermoplastic compound, Ez type	H7 Extruded double layer insulated cable
E4 Cross-linked polyethylene compound, E4M type	H8 Extensible cord
G Natural and/or synthetic rubber compound, Gy	Extensible cord
G6 Chloro-sulphurine polyethylene compound, G6M type	D Flexible conductor for arc welding machines cables in conformity with HD 22 Part 6 (different flexibility from HD 383 standard, Class 5)
K Noprene or similar compound, Ky, Kn, Kz type	E Very flexible conductor for arc welding machines cables in conformity with HD 22 Part 6 (different flexibility from HD 383 standard, Class E)
R Polyvinyl chloride compound, Tm1, Tm2 type, Rz type	F Flexible conductor for a flexible cable (in conformity with HD 383 standard, Class 5)
R4 Polyamide resin compound	H Very flexible conductor for a flexible cable (in conformity with HD 383 standard, Class 6)
M1 Thermoplastic compound with low emission of smoke and toxic and corrosive gases	K Flexible conductor for fixed installation (in conformity with HD 383 standard, Class 5)
M2 Elastomeric compound with low emission of smoke and toxic and corrosive gases, M2 type	R Stranded rigid conductor
M3 Elastomeric compound with low emission of smoke and toxic and corrosive gases, M3 type	U Rigid bare conductor
M4 Elastomeric compound with low emission of smoke and toxic and corrosive gases, M4 type	Y Copper-similar conductor
T1 Binding with glass tape	
T Textile braid (impregnated if necessary)	
T2 T2 Special textile braid (impregnated if necessary)	
Cable shape	
O Assembled cores (with covering if necessary), with or without fillers to form a round cable	
D Cores as above, close together in parallel (flattened cable outside)	
X Assembled cores as above, with triplex assembly	
W Cores joined in parallel with an intermediary furrow	
W1 Cores joined in parallel with an intermediary insulating filler	
Self supporting element	
S Metallic rope, embedded in a non-metallic sheath	
Y Textile or metallic rope among the cores or externally tied to the cable	

COSTRUCTION CODE

Power cables acc. to VDE 0250	Harmonized cables acc. to VDE 0281/0282	Telecommunication cables acc. to VDE 0815/0816	Power cables acc. to VDE 0276
1. Reference standards	1. Reference standards	1. Reference standards	1. Reference standards
N according to VDE	H Harmonized type (HAR)	A outdoor cable	N according to VDE
N)/X with reference to VDE	A authorised national standards	G mining cable	(N) with reference to VDE
2. Sheath insulating material	2. Nominal voltage	J installation cable	2. Conductor
Y PVC	01 100 V	L equipment wire	- copper
4Y polyamide	03 300/300 V	S switch cable	A aluminium
5Y PTFE (teflon)	05 300/500 V	Li equipment wire with fine stranded conductor	3. Sheath insulating material
6Y FEP (teflon)	07 450/750 V	RD rhenomatic-cable	Y PVC
9Y polypropylen	11 600/1000 V	RE instrumentation cable	2Y PE
11Y polyurethan (PUR)	3. Sheath insulating material	2. Additional specifications	2X XLPE
2X XLPE	V PVC	B lightning protection	H LSOH compound
G elastomer	V2 PVC (90 °C)	J Induktion protection	4. Concentric conductor
2G silicon	V3 PVC cold-resistant	E Industry-electronics	C Concentric copper conductor
3G EPR-rubber	B EPR-rubber (90 °C)	3. Sheath insulating material	CW Concentric copper conductor reversing lay up
4G EVA	G EVA	Y PVC	5. Screen
5G polychloroprene	E PE	2Y PE	S common copper shield
HX LSOH	R natural or synthetic rubber	02Y cell-PE	SE individually screened cores
3. Cable description	S silicon rubber	02YS foam-Skin	6. Metal sheath
A single-core	X XLPE	5Y PTFE (teflon)	K lead
D solid wire	Z LSOH -compound	6Y FEP (teflon)	7. Inner protection or plastic sheath (see 3.insulation materials)
AF single-core, fine stranded	4. Sheath materials	7Y ETFE (teflon)	8. Armouring
F flexible wire for fittings	V PVC	P paper	F flat steel wire
L fluorescent tube cable	V2 PVC (90 °C)	4. Special construction	R round steel wire
LH connecting cable for light mechanical load	V3 PVC cold-resistant	F petrol jelly filler	G steel tape
MH connecting cable for middle mechanical load	V4 PVC cross-linked	L aluminium sheath	9. Outer sheath (see 3.insulation materials)
SH connecting cable for, heavy mechanical load	V5 PVC oil-resistant	LD corrugated Al.-sheath	10. Protective conductor
SSH connecting cable for special mechanical load	R natural or synthetic rubber	(L) laminated aluminium sheath	-J with green/yellow core
SL control/welding cable	N chloroprene rubber	C copper braided screen	-O without green/yellow core
S control cable	N2 chloroprene rubber for welding cables	(St) screen of plastic coated Al-foil	11. Number of cores
LS light control cable	N4 chloroprene rubber heat- resistant	(K) copper tape screen	12. Conductor form
FL flat cable	N8 chloroprene rubber (water-resistant)	(B) armouring	RE round, solid
Si silicon cable	J glass fibre braid	(Z) steel wire armouring	RM round, stranded
Z twin cable	T textil braid	(Zg) strain-bearing element with glass yarn bundles	SE sector shaped, solid
GL glass fibre	T6 textil over each core	(ZN) strain-bearing element non metallic	SM sector shaped, stranded
Li stranded wires acc. to VDE 0812	Q polyurethan (PUR)	W corrugated steel sheath	
LIF fine stranded wires acc. to VDE 0812	Q4 polyamide	M lead sheath	
4. Special constructions	Z LSOH -compound	Mz special lead sheath	
T strength member	5. Special constructions	b armouring	
ö oil-resistant	C concentric copper conductor	c jute jacket+ bituminous compound	
u flame resistant	C4 copper braided screen	E compound with embedded tape	
w heat-/weather resistant	H flat, divisible cords	5. Sheathing materials (see 3.insulation materials)	
FE fire resistant	H2 flat, non divisible cords	6. Number of elements (number of stranding elements)	
C screen	H6 flat, non divisible cords for elevators	7. Stranding elements	
S steel wire armouring	H7 two-layer insulating jacket	8. Conductor diameter	
5. Sheath materials (see 2. insulation materials)	H8 helical cord	2 pair	
P Polyurethan	6. Conductor form	4 quad	
6. Protective conductor	U round, solid	6. Conductor form	
-J with green/yellow core	R round, stranded	U round, solid	
-O without green/yellow core	K fine stranded, (fixed installation)	R round, stranded	
7. Number of cores	F fine stranded (flexibel cords)	K fine stranded, (fixed installation)	
8. Cross-section of conductor	H fine stranded (highly flexibile)	F fine stranded (flexibel cords)	
	Y tensil conductor	H fine stranded (highly flexibile)	
	D fine stranded for welding cables	Y tensil conductor	
	E fine stranded for welding cables (highly flexibile)	D fine stranded for welding cables	
	7. Number of cores	E fine stranded for welding cables (highly flexibile)	
	8. Protective conductor	7. Number of cores	
	X without green/yellow core	8. Protective conductor	
	G with green/yellow core	9. Type of stranding	
	9. Cross-section of conductor	F star quad (railway)	
		St star quad with phantom circuit (long distance)	
		St I star quad (long distance)	
		St III star quad (subscriber line)	
		TF star quad for carrier frequency	
		PiMF pair in metal foil DIMF triple in metal foil	
		ViMF quad in metal foil	
		10. Stranding layout	
		Lg stranding in layer	
		Bd stranding in unit	

COSTRUCTION CODE

Fiber-optic cables acc. to VDE 0888	
1. Application	
J	indoor cable
A	outdoor cable
AT	outdoor cable, breakout type
A/J*	universal cable for outdoor and indoor use
ADSS*	metal-free self supporting overhead cable
2. Tube	
V	tight buffer
D	loose-tube, filled
W	hollow-tube, filled
E	loose-tube, flexible
3. Constructions	
ZS	metal strain relief element/strain relief element in cable-core assembly
S	metal stranding element in cable-core assembly
F	filling compound for filling of stranding interstices in the cable-core assembly
OF	special filling compound for filling of stranding interstices
Q	longitudinal cable-core assembly water-tightness via expanding material
4. Cable sheath	
Y	PVC sheath
H	Halogen-free, flame resistant plastic sheath
2Y	PE sheath
4Y	PA sheath
11Y	PUR sheath
(L)2Y	aluminium multi-layer sheath
(SR)2Y	corrugated steel tape reinforcement under PE sheath
(ZN)2Y	non-metallic strain relief element under PE sheath
(ZN)B2Y	non-metallic strain relief element and rodent-protection under PE sheath
(ZN)BH	non-metallic strain relief element and rodent-protection under Halogen free, flame resistant plastic sheath
(ZN)(L)2Y	non-metallic strain relief element under aluminium multi-layer sheath
(ZN)(SR)2Y	non-metallic strain relief element under corrugated steel tape reinforcement with PE sheath
	number of tubes with one fiber for hollow-core cables
	number of loose-tubes for number of fibers per loose-tube for loose-tube cables
5. Type	
E	single-mode fibers
G	graded-index fiber (multi-mode)
Core	Ø in µm for graded index multimode fibers or
Field	Ø in µm for single-mode fibers
	cladding Ø in µm
	coefficient of attenuation in dB/km
5. Wavelength	
B	850 nm
F	1300 nm bei G, 1310nm for E
H	1550 nm
6. Bandwidth	
	MHz * 1 km for G or coefficient of dispersion in ps/(nm* km) for E
LG	concentr.stranded
SZ	SZ-stranding

STRAND MAKE-UP

STRAND MAKE-UP ACCORDING TO DIN VDE 0295 and IEC 60228

Cross section mm ²	Stranded wires	Multi-Stranded wires	Fine wires	Extra-fine wires
	Class 2 DIN VDE 0295		Class 5 DIN VDE 0295	Class 6 DIN VDE 0295
	1	2	3	4
	Number of single wires x wire Ø mm	Number of single wires x wire Ø mm	Number of single wires x wire Ø mm	Number of single wires x wire Ø mm
0,05				
0,08				
0,09				
0,14			± 18x0,1	± 18x0,1
0,25			± 14x0,15	± 32x0,1
0,34		7x0,25	± 19x0,15	± 42x0,1
0,38		7x0,27	± 12x0,2	± 21x0,15
0,5	7x0,30	7x0,30	± 16x0,2	± 28x0,15
0,75	7x0,37	7x0,37	± 24x0,2	± 42x0,15
1,0	7x0,43	7x0,43	± 32x0,2	± 56x0,15
1,5	7x0,52	7x0,52	± 30x0,25	± 84x0,15
2,5	7x0,67	19x0,41	± 50x0,25	± 140x0,15
4	7x0,85	19x0,52	± 56x0,3	± 224x0,15
6	7x1,05	19x0,64	± 84x0,3	± 192x0,2
10	7x1,35	49x0,51	± 80x0,4	± 320x0,2
16	7x1,70	49x0,65	± 128x0,4	± 512x0,2
25	7x2,13	84x0,62	± 200x0,4	± 800x0,2
35	7x2,52	133x0,58	± 280x0,4	± 1120x0,2
50	19x1,83	133x0,69	± 400x0,4	± 705x0,3
70	19x2,17	189x0,69	± 356x0,5	± 990x0,3
95	19x2,52	259x0,69	± 485x0,5	± 1340x0,3
120	37x2,03	336x0,67	± 614x0,5	± 1690x0,3
150	37x2,27	392x0,69	± 765x0,5	± 2123x0,3
185	37x2,52	494x0,69	± 944x0,5	1470x0,4
240	61x2,24	627x0,70	± 1225x0,5	± 1905x0,4
300	61x2,50	790x0,70	± 1530x0,5	± 2385x0,4
400	61x2,89		± 2035x0,5	
500	61x3,23		± 1768x0,6	
630	91x2,97		± 2228x0,6	

Permissible maximal diameter of single wire	
nominal value mm	maximal value mm
0,2	0,21
0,25	0,26
0,3	0,31
0,4	0,41
0,5	0,51
0,6	0,51

STRAND MAKE-UP

COPPER CONDUCTOR AND STRANDING DATA

Approx outer Ø	Pounds per 1000 ft.	Circular Mils	Size AWG/CM	CONCENTRIC STRAND					ROPE LAY Concentric Strand		ROPE LAY Bunch Strand	
				Class AA	Class A	Class B	Class C	Class D	Class G	Class H	Class K 30AWG (.010")	Class M 34AWG (.0063")
.0050	.0757	25.00	36									
.0056	.0954	31.52	35									
.0063	.1203	39.75	34									
.0071	.1517	50.13	33									
.0080	.1913	63.21	32									
.0089	.2413	79.70	30									
.0100	.3042	100.5	30									
.0113	.3836	126.7	29									
.0126	.4837	159.8	28									
.0142	.6100	201.5	27									
.0159	.7692	254.1	26									
.0179	.9699	320.4	25									
.0201	1.223	404.0	24									
.0226	1.542	509.5	23									
.0254	1.945	642.4	22									
.0285	2.452	810.1	21									
.0363	3.154	1,020	20			7	19				10	26
.0456	5.015	1,620	18			7	19				16	41
.0576	7.974	2,580	16			7	19				26	65
.0726	12.68	4,110	14			7	19	37	49		41	104
.0915	20.16	6,530	12			7	19	37	49		65	186
.1160	32.06	10,380	10			7	19	37	49		104	259
.1600	40.42	13,090	9			7	19	37	49	133		
.1460	51.0	16,510	8			7	19	37	49	133	168	420
.1840	80.9	26,240	6			7	19	37	49	133	266	665
.2320	129	41,740	4	3	7	7	19	37	49	133	420	1064
.2600	162	52,620	3	3	7	7	19	37	49	133	532	1323
.2990	205	66,630	2	3	7	7	19	37	49	133	665	1666
.3320	259	83,690	1	3	7	19	37	61	133	259	836	2107
.3730	326	105,600	1/0	7	7	19	37	61	133	259	1064	2646
.4190	411	133,100	2/0	7	7	19	37	61	133	259	1323	3325
.4700	518	167,800	3/0	7	7	19	37	61	133	259	1666	4256
.5280	653	211,600	4/0	7	7	19	37	61	133	259	2107	5320
.5750	772	250,000	250,000	12	19	37	61	91	259	427	2499	6384
.6300	925	300,000	300,000	12	19	37	61	91	259	427	2989	7581
.6810	1080	350,000	350,000	12	19	37	61	91	259	427	3458	8806
.7280	1236	400,000	400,000	19	19	37	61	91	259	427	3990	10,101
.8130	1542	500,000	500,000	19	37	37	61	91	259	427	5054	12,691
.8930	1850	600,000	600,000	37	37	61	91	127	427	703	5985	14,945
.9980	2316	750,000	750,000	37	61	61	91	127	427	703	7581	18,788
1.152	3086	1,000,000	1,000,000	37	61	61	91	127	427	703	10,101	25,193

STRAND MAKE-UP

DIMENSION AND WEIGHTS OF SOLID COPPER WIRE

Size AWG	Approximate Diameter	Circular Mils	Square Inches	Approximate Lbs/Mft
34	0,00063	39,7	0,0000312	0,120
32	0.0080	64.0	0.0000503	0.194
30	0.0100	100	0.0000785	0.303
29	0.0113	128	0.000100	0.387
28	0.0126	159	0.000125	0.481
27	0.0142	202	0.000158	0.610
26	0.0159	253	0.000199	0.765
25	0.0179	320	0.000252	0.970
24	0.0201	404	0.000317	1.22
23	0.0226	511	0.000401	1.55
22	0.0253	640	0.000503	1.94
21	0.0285	812	0.000638	2.46
20	0.0320	1020	0.000804	3.10
18	0.0403	1620	0.00128	4.92
16	0.0508	2580	0.00203	7.81
14	0.0641	4110	0.00323	12.4
12	0.0808	6530	0.00513	19.8
10	0.1019	10,380	0.00815	31.43
9	0.1144	13,090	0.01028	39.62
8	0.1285	16,510	0.01297	49.98
7	0.1443	20,820	0.01635	63.03
6	0.1620	26,240	0.02061	79.44
5	0.1819	33,090	0.02599	100.2
4	0.2043	41,740	0.03278	130.3
3	0.2294	52,620	0.04133	159.3
2	0.2576	66,360	0.05212	200.9

STRANDING-CLASS CONSTRUCTION AND USES

Concentric-lay Conductors	
Class B	Power cables
Class C	Power cables where more flexible stranding from Class B is desired
Class D	Power cables where extra flexible stranding is desired
Rope-lay and Bunch-stranded Conductors	
Class G	All cables for portable use
Class H	All cables where extreme flexibility is required, e.g. take-up reels
Class I	Apparatus cable and motor leads
Class K	Cords and cables 30 AWG copper wires - Stationary service
Class M	Cords and cables 34 AWG copper wires - Constant service

Note: Class G and H shall have concentric-lay stranded members and Class I, K and M shall have bunched stranded members.

CONVERSION FROM AWG

AMERICAN/EUROPEAN TABLE COMPARISON FROM AWG TO mm²

AWG Number	Cross section mm ² (AMERICAN COMPARISON)	Cross section mm ² (EUROPEAN COMPARISON)	Ø mm	Conductor resistance Ω/km
1000 MCM	507	500	29,3	0,036
900	456	-	27,8	0,04
750	380	400	25,4	0,048
600	304	300	22,7	0,061
550	279	-	21,7	0,066
500	253	240	20,7	0,07
450	228	-	19,6	0,08
400	203	-	18,5	0,09
350	177	185	17,3	0,1
300	152	150	16	0,12
250	127	-	14,6	0,14
4/0	107,2	120	11,68	0,18
3/0	85	95	10,4	0,23
2/0	67,4	70	9,27	0,29
0	53,4	-	8,25	0,37
1	42,4	50	7,35	0,47
2	33,6	35	6,54	0,57
3	26,7	-	5,83	0,71
4	21,2	25	5,19	0,91
5	16,8	-	4,62	1,12
6	13,3	16	4,11	1,44
7	10,6	-	3,67	1,78
8	8,34	10	3,26	2,36
9	6,62	-	2,91	2,77
10	5,26	6	2,59	3,64
11	4,15	-	2,3	4,44
12	3,31	4	2,05	5,41
13	2,63	-	1,83	7,02
14	2,08	2,5	1,63	8,79
15	1,65	-	1,45	11,2
16	1,31	1,5	1,29	14,7
17	1,04	-	1,15	17,8
18	0,823	1	1,024	23
19	0,653	0,75	0,912	28,3
20	0,519	0,5	0,812	34,5
21	0,412	0,38	0,723	44
22	0,324	0,34	0,644	54,8
23	0,259	-	0,573	70,1
24	0,205	0,25	0,511	89,2
25	0,163	-	0,455	111
26	0,128	0,14	0,405	146
27	0,102	-	0,361	176
28	0,0804	0,08	0,321	232
29	0,0646	-	0,286	282
30	0,0503	0,05	0,255	350
31	0,04	-	0,227	446
32	0,032	-	0,202	578
33	0,0252	-	0,18	710
34	0,0200	-	0,16	899
35	0,0161	-	0,143	1125
36	0,0123	-	0,127	1426
37	0,01	-	0,113	1800
38	0,00795	-	0,101	2255
39	0,00632	-	0,0897	2860

4/0 is also known as 0000; 1 mil = inch = 0.0254 mm
*Shown in MCM (circular mills) for bigger cross sections

1 CM = 1 Circ. mil = 0.0005067 mm²
1 MCM = 1000 Circ. mils = 0.5067 mm²

1 CM = 1 Circ. mil = 0.0005067 mm²
1 MCM = 1000 Circ. mils = 0.5067 mm²

GENERAL CONVERSION

GENERAL CONVERSION TABLE

LENGHT		
From	to	Formula
Inch (In)	millimeter (mm)	$In \times 25,4 = mm$
millimeter (mm)	Inch (In)	$mm \times 0,03937 = In$
foot (ft)	meter (m)	$ft \times 0,3048 = m$
meter (m)	foot (ft)	$mt \times 3,218 = ft$
mile (mi)	kilometer (km)	$mi \times 1,609 = km$
kilometer (km)	mile (mi)	$km \times 0,662 = mi$

WEIGHTS		
From	to	Formula
pound (lb)	kilogram (kg)	$lb \times 2,205 = kg$
kilogram (kg)	pound (lb)	$kg : 2,205 = lb$

TEMPERATURE		
From	to	Formula
Fahrenheit (F)	Celsius (C)	$(F-32) \times 0,56 = C$
Celsius (C)	Fahrenheit (F)	$C \times 1,8 + 32 = F$

COLOUR CODE

ELETTROTEK KABEL SINGLE WIRES COLOUR IDENTIFICATION

Core. no	Basic color	RAL
01	BLACK / NERO	9005
02	DARK BLUE / BLU SCURO (RAL 5010)	5010
03	BROWN / MARRONE	8003
04	GREY / GRIGIO	7000
05	YELLOW / GIALLO	1021
06	GREEN / VERDE	6018
07	VIOLET/ VIOLA	4005
08	WHITE / BIANCO	9003
09	ORANGE / ARANCIONE	2003
10	RED / ROSSO	3000
11	LIGHT BLUE / BLU CHIARO (RAL 5015)	5015
12	LIGHT BLUE / BLU CHIARO (RAL 5012)	5012
13	PINK / ROSA	3015
14	SKY BLUE/BLU SKY	5024
15	YELLOW-GREEN / GIALLO-VERDE	1021/6018
16	WHITE-DARK BLUE / BIANCO-BLU SCURO	9003/5010
17	DARK BLUE-WHITE / BLU-BIANCO	5010/9003
18	WHITE-GREY / BIANCO-GRIGIO	9003/7000
19	BLACK-GREEN / NERO-VERDE	9005/6018
20	BLACK-DARK BLUE / NERO-BLU SCURO	9005/5010
21	BLACK-WHITE / NERO-BIANCO	9005/9003
22	BLACK-VIOLET / NERO-VIOLA	9005/4005
23	BLACK-RED / NERO-ROSSO	9005/3000
24	WHITE-RED / BIANCO-ROSSO	9003/3000
25	WHITE-BROWN / BIANCO- MARRONE	9003/8003
26	DARK BLUE-RED / BLU SCURO-ROSSO	5010/3000
27	WHITE-VIOLET / BIANCO-VIOLA	9003/4005
28	WHITE-YELLOW / BIANCO-GIALLO	9003/1021
29	WHITE-GREEN / BIANCO-VERDE	9003/6018
30	WHITE-ORANGE / BIANCO-ARANCIONE	9003/2003
31	OFF WHITE GREY	9002
32	REDDISH BROWN	3016
33	BEIGE	1001
34		
35		
36		
37		
38		
39		

HD 308 S2

no. of cores	Cores with green-yellow protective conductor (-J)	Cores without green-yellow protective conductor (-O)
2	-	BLUE-BROWN
3	GREEN/YELLOW-BLUE-BROWN	BROWN-BLACK-GREY
4	GREEN/YELLOW-BROWN-BLACK-GREY	BLUE-BROWN-BLACK-GREY
5	GREEN/YELLOW-BLUE-BROWN-BLACK-GREY	BLUE-BROWN-BLACK-GREY-BLACK
6	GREEN-YELLOW/BLACK + WHITE PRINTED NUMBERS	BLACK + WHITE PRINTED NUMBERS

Core identification with numbers acc. to EN 50334

Marking inscription for identification of cores of electric cables (number printing).
Other core colours are allowed except green and yellow.

COLOUR CODE

DIN 47100

Number	Colour	Number	Colour
1	WHITE	32	YELLOW - blue
2	BROWN	33	GREEN - red
3	GREEN	34	YELLOW - red
4	YELLOW	35	GREEN - black
5	GRAY	36	YELLOW - black
6	PINK	37	GRAY - blue
7	BLUE	38	PINK - blue
8	RED	39	GRAY - red
9	BLACK	40	PINK - red
10	VIOLET	41	GRAY - black
11	GRAY - pink	42	PINK - black
12	RED - blue	43	BLUE - black
13	WHITE - green	44	RED - black
14	BROWN - green	45	WHITE - brown - black
15	WHITE - yellow	46	YELLOW - green - black
16	YELLOW - brown	47	GRAY - pink - black
17	WHITE - gray	48	RED - blue - black
18	GRAY - brown	49	WHITE - green - black
19	WHITE - pink	50	BROWN - green- black
20	PINK - brown	51	WHITE - yellow - black
21	WHITE - blue	52	YELLOW - brown - black
22	BROWN - blue	53	WHITE - gray - black
23	WHITE - red	54	GRAY - brown - black
24	BROWN - red	55	WHITE - pink - black
25	WHITE - black	56	PINK - brown - black
26	BROWN - black	57	WHITE - blue - black
27	GRAY - green	58	BROWN - blue - black
28	YELLOW - gray	59	WHITE - red - black
29	PINK - green	60	BROWN- red - black
30	YELLOW - pink	61	BLACK - white
31	GREEN - blue		

COLOUR CODE

COLOUR CODE FOR CABLES JB/OB

The combination of color identification up to 101 cores consists of 11 basic colors. For core 12 and more, one or two additional color rings or longitudinal stripes are printed on the basic color. This ring width is approximately 2mm. The insulation of the conductor gives the first basic color.

JB COLOUR CODE

Number	Color	Number
0 GREEN/YELLOW	34 PINK/BLUE	68 ORANGE/WHITE/BLACK
1 WHITE	35 ORANGE/BLUE	69 TRANS/WHITE/BLACK
2 BLACK	36 TRANS/BLUE	70 BEIGE/WHITE/BLACK
3 BLUE	37 BEIGE/BLUE	71 BROWN/WHITE/BLUE
4 BROWN	38 GRAY/BROWN	72 GRAY/WHITE/BLUE
5 GRAY	39 RED/BROWN	73 RED/WHITE/BLUE
6 RED	40 VIOLET/BROWN	74 VIOLET/WHITE/BLUE
7 VIOLET	41 PINK/BROWN	75 PINK/WHITE/BLUE
8 PINK	42 ORANGE/BROWN	76 ORANGE/WHITE/BLUE
9 ORANGE	43 TRANS/BROWN	77 TRANS/WHITE/BLUE
10 TRANSPARENT	44 BEIGE/BROWN	78 BEIGE/WHITE/BLUE
11 BEIGE	45 RED/GRAY	79 GRAY/WHITE/BROWN
12 BLACK/WHITE	46 VIOLET/GRAY	80 RED/WHITE/BROWN
13 BLUE/WHITE	47 PINK/GRAY	81 VIOLET/WHITE/BROWN
14 BROWN/WHITE	48 ORANGE/GRAY	82 PINK/WHITE/BROWN
15 GRAY/WHITE	49 TRANS/GRAY	83 ORANGE/WHITE/BROWN
16 RED/WHITE	50 BEIGE/GRAY	84 TRANS/WHITE/BROWN
17 VIOLET/GRAY	51 ORANGE/RED	85 BEIGE/WHITE/BROWN
18 PINK/WHITE	52 TRANS/RED	86 RED/WHITE/GRAY
19 ORANGE/WHITE	53 BEIGE/RED	87 VIOLET/WHITE/GRAY
20 TRANS/WHITE	54 PINK/VIOLET	88 PINK/WHITE/GRAY
21 BEIGE/WHITE	55 ORANGE/VIOLET	89 ORANGE/WHITE/GRAY
22 BLUE/BLACK	56 TRANS/VIOLET	90 TRANS/WHITE/GRAY
23 BROWN/BLACK	57 BEIGE/VIOLET	91 BEIGE/WHITE/GRAY
24 GRAY/BLACK	58 TRANS/PINK	92 BLUE/WHITE/RED
25 RED/BLACK	59 BEIGE/PINK	93 BROWN/WHITE/RED
26 VIOLET/BLACK	60 TRANS/ORANGE	94 VIOLET/WHITE/RED
27 PINK/BLACK	61 BEIGE/ORANGE	95 PINK/WHITE/RED
28 ORANGE/BLACK	62 BLUE/WHITE/BLACK	62 BLUE/WHITE/BLACK
29 TRANS/BLACK	63 BROWN/WHITE/BLACK	97 BROWN/WHITE/VIOLET
30 BEIGE/BLACK	64 GRAY/WHITE/BLACK	98 ORANGE/WHITE/VIOLET
31 BROWN/BLUE	65 RED/WHITE/BLACK	99 BROWN/BLACK/BLUE
32 GRAY/BLUE	66 VIOLET/WHITE/BLACK	100 GRAY/BLACK/BLUE
33 RED/BLUE	67 PINK/WHITE/BLACK	101 RED/BLACK/BLUE

COLOUR CODE

The cores are to be counted continuously through all layers at the same direction, beginning with the inner layer towards the outside layer

OB COLOUR CODE

Number	Color	Number
1 WHITE	35 ORANGE/BLUE	69 TRANS/WHITE/BLACK
2 BLACK	36 TRANS/BLUE	70 BEIGE/WHITE/BLACK
3 BLUE	37 BEIGE/BLUE	71 BROWN/WHITE/BLACK
4 BROWN	38 GRAY/BROWN	72 GRAY/WHITE/BLUE
5 GRAY	39 RED/BROWN	73 RED/WHITE/BLUE
6 RED	40 VIOLET/BROWN	74 VIOLET/WHITE/BLUE
7 VIOLET	41 PINK/BROWN	75 PINK/WHITE/BLUE
8 PINK	42 ORANGE/BROWN	76 ORANGE/WHITE/BLUE
9 ORANGE	43 TRANS/BROWN	77 TRANS/WHITE/BLUE
10 TRANSPARENT	44 BEIGE/BROWN	78 BEIGE/WHITE/BLUE
11 BEIGE	45 RED/GRAY	79 GRAY/WHITE/BROWN
12 BLCK/WHITE	46 RED/GRAY	80 RED/WHITE/BROWN
13 BLUE/WHITE	47 PINK/GRAY	81 VIOLET/WHITE/BROWN
14 BROWN/WHITE	48 ORANGE/GRAY	82 PINK/WHITE/BROWN
15 GRAY/WHITE	49 TRANS/GRAY	83 ORANGE/WHITE/BROWN
16 RED/WHITE	50 BEIGE/GRAY	84 TRANS/WHITE/BROWN
17 VIOLET/GRAY	51 ORANGE/RED	85 BEIGE/WHITE/BROWN
18 PINK/WHITE	52 TRANS/RED	86 RED/WHITE/GRAY
19 ORANGE/WHITE	53 BEIGE/RED	87 VIOLET/WHITE/GRAY
20 TRANS/WHITE	54 PINK/VIOLET	88 PINK/WHITE/GRAY
21 BEIGE/WHITE	55 ORANGE/VIOLET	89 ORANGE/WHITE/GRAY
22 BLUE/BLACK	56 TRANS/VIOLET	90 TRANS/WHITE/GRAY
23 BROWN/BLACK	57 BEIGE/VIOLET	91 BEIGE/WHITE/GRAY
24 GRAY/BLACK	58 TRANS/PINK	92 BLUE/WHITE/RED
25 RED/BLACK	59 BEIGE/PINK	93 BROWN/WHITE/RED
26 VIOLET/BLACK	60 TRANS/ORANGE	94 VIOLET/WHITE/RED
27 PINK/BLACK	61 BEIGE/ORANGE	95 PINK/WHITE/RED
28 ORANGE/BLACK	62 BLUE/WHITE/BLACK	96 ORANGE/WHITE/RED
29 TRANS/BLACK	63 BROWN/WHITE/BLACK	97 BROWN/WHITE/VIOLET
30 BEIGE/BLACK	64 GRAY/WHITE/BLACK	98 ORANGE/WHITE/VIOLET
31 BROWN/BLUE	65 RED/WHITE/BLACK	99 BROWN/BLACK/BLUE
32 GRAY/BLUE	66 VIOLET/WHITE/BLACK	100 GRAY/BLACK/BLUE
33 RED/BLUE	67 PINK/WHITE/BLACK	101 RED/BLACK/BLUE
34 PINK/BLUE	68 ORANGE/WHITE/BLACK	

COLOUR CODE

DIN 0815

1. Colour coding for installation cables

J-Y(St)Y ... Lg

For two-pair cable		
pair 1	A-RED	B-BLACK
pair 2	A-WHITE	B-YELLOW

For cables with more than 2 pairs	
The colour of the a-core in the first pair of each layer is red ("counting" pair), in all other pairs it is white.	
The colour of the b-core is blue, yellow, green, brown, black in repeating order as follows:	

colour of b-core	Nr. of pair									
blue	1	6	11	16	21	26	31	36	41	46
yellow	2	7	12	17	22	27	32	37	42	47
green	3	8	13	18	23	28	33	38	43	48
brown	4	9	14	19	24	29	34	39	44	49
black	5	10	15	20	25	30	35	40	45	50

blue	51	56	61	66	71	76	81	86	91	96
yellow	52	57	62	67	72	77	82	87	92	97
green	53	58	63	68	73	78	83	88	93	98
brown	54	59	64	69	74	79	84	89	94	99
black	55	60	65	70	75	80	85	90	95	100

2. Colour coding for installation cables

JE-Y(St)Y... Bd JE-LiYCY mBd JE-H(St)H Bd JE-LIHCH Bd RD-Y(St)Y AJ-Y(St)YDY Bd Si

For two-pair cable		
pair 1	A-BLUE	B-RED
pair 2	A-GREY	B-YELLOW

For cables with more than 2 pairs.
Colour of basic insulation of pairs in one bunch:

Pair	1		2		3		4	
	a	b	a	b	a	b	a	b
colour	BLUE	RED	GREY	YELLOW	GREEN	BROWN	WHITE	BLACK

For identification of bunches, cores are marked with black rings and bunches are wrapped by a colored tape.



COLOUR CODE

Identification of bunches

Bunch-N°	Colour of rings	rings for bunches of		Tape
		4 cores	a cores resp. 4 pairs	
1	PINK	I	I	-
2		I	II	-
3		II	III	-
4		II	IV	-
5	ORANGE		I	-
6			II	-
7			III	-
8			IV	-
9	VIOLET		I	-
10			II	-
11			III	-
12			IV	-
13	PINK		I	BLUE
14			II	
15			III	
16			IV	
17	ORANGE		I	RED
18			II	
19			III	
20			IV	

3. Colour coding for installation cables

J-YY ... Bd J-H(St)H ... Bd J-2Y(St)Y St III Bd

The five star-quads of each bunch have the following identification:	
1 basic	insulation of all cores red
2 basic	insulation of all cores green
3 basic	insulation of all cores grey
4 basic	insulation of all cores yellow
5 basic	insulation of all cores white

The cores within one star-quad are marked by rings:

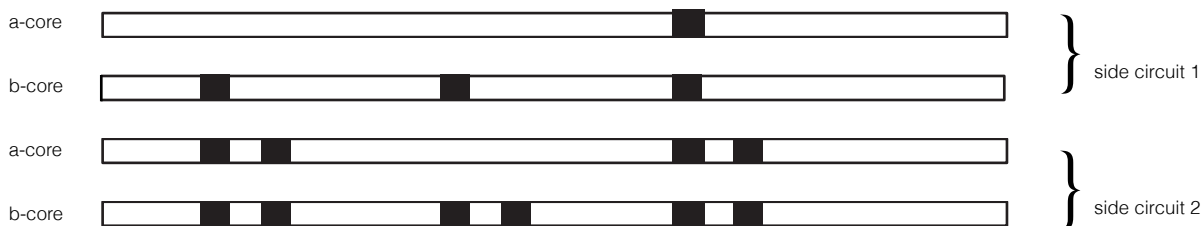

The counting bunch is marked by a red tape in each layer. All other bunches have a white or nature tape.

COLOUR CODE

DIN 0816

4. Core identification for outdoor telephone cables

The five star-quads of each basic unit have the following identification:	
1 quad	basic insulation of all cores red
2 quad	basic insulation of all cores green
3 quad	basic insulation of all cores grey
4 quad	basic insulation of all cores yellow
5 quad	basic insulation of all cores white

The basic insulation of spare quads is red.

The cores within one star-quad are marked by rings:

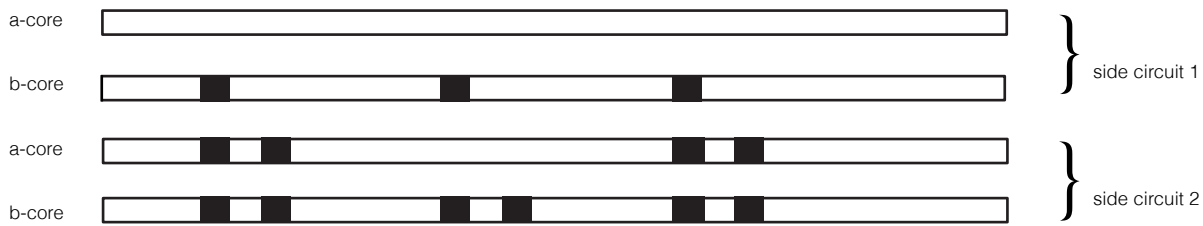

The first basic- or main-unit in each layer is to be marked by an open helix of plastic tape of red (marker). All other basic- or main-units must be wrapped with an open helix of white or uncoloured plastic tape. The quads of a basic-unit are to be counted according to the sequence of basic colours. In cables with more than 5 star-quads, the basic- and main-units must be counted continuously beginning with maker-unit at inner layer towards outside.

Examples for unit stranding

5 star-quads stranded into basic unit

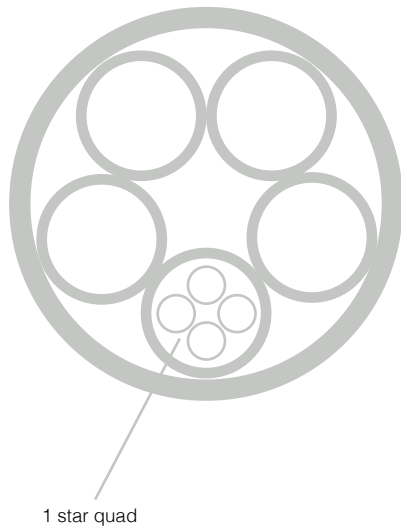

5 basic units each stranded into one main unit = 50 D

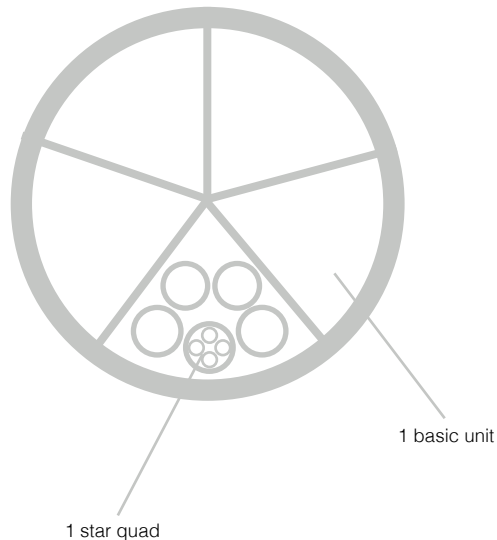

COLOUR CODE

BS 5308 Part I

Multipair colour code		
pair n°	A wire	B wire
1	BLACK	BLUE
2*	BLACK	GREEN
3	BLUE	GREEN
4	BLACK	BROWN
5	BLUE	BROWN
6	GREEN	BROWN
7	BLACK	WHITE
8	BLUE	WHITE
9	GREEN	WHITE
10	BROWN	WHITE
11	BLACK	RED
12	BLUE	RED
13	GREEN	RED
14	BROWN	RED
15	WHITE	RED
16	BLACK	ORANGE
17	BLUE	ORANGE
18	GREEN	ORANGE
19	BROWN	ORANGE
20	WHITE	ORANGE
21	RED	ORANGE
22	BLACK	YELLOW
23	BLUE	YELLOW
24	GREEN	YELLOW
25	BROWN	YELLOW
26	WHITE	YELLOW
27	RED	YELLOW
28	ORANGE	YELLOW
29	BLACK	GREY
30	BLUE	GREY
31	GREEN	GREY
32	BROWN	GREY
33	WHITE	GREY
34	RED	GREY
35	ORANGE	GREY
36	YELLOW	GREY
37	BLACK	VIOLET
38	BLUE	VIOLET
39	GREEN	VIOLET
40	BROWN	VIOLET
41	WHITE	VIOLET
42	RED	VIOLET
43	ORANGE	VIOLET
44	YELLOW	VIOLET
45	GREY	VIOLET
46	BLACK	TURQUOISE
47	BLUE	TURQUOISE
48	GREEN	TURQUOISE
49	BROWN	TURQUOISE
50	WHITE	TURQUOISE

* Single quad (2 pair) Black, Blue, Green and Brown

IDENTIFICATION OF PAIRS: two pair, unscreened or collectively screened cables shall be cabled in quad formation and colour coded in clockwise order or rotation: black,blue,green,brown

PAIR IDENTIFICATION: unscreende pairs shall be identified by means of coloured insulation in the sequence in the table, starting at the centre.

Screened pairs shall be identified either:

- by means of coloured insulation in the sequence in the table, starting at the centre or
- by a numbered polyester film which shall also serve as part of the screen insulation, in which case each pair in the cable shall have one black and one blue core.

COLOUR CODE

BS 5308 Part 2

Multipair colour code		
pair n°	A wire	B wire
1	WHITE	BLUE
2*	WHITE	ORANGE
3	WHITE	GREEN
4	WHITE	BROWN
5	WHITE	GREY
6	RED	BLUE
7	RED	ORANGE
8	RED	GREEN
9	RED	BROWN
10	RED	GREY
11	BLACK	BLUE
12	BLACK	ORANGE
13	BLACK	GREEN
14	BLACK	BROWN
15	BLACK	GREY
16	YELLOW	BLUE
17	YELLOW	ORANGE
18	YELLOW	GREEN
19	YELLOW	BROWN
20	YELLOW	GREY
21	WHITE-Blue	BLUE
22	WHITE-Blue	ORANGE
23	WHITE-Blue	GREEN
24	WHITE-Blue	BROWN
25	WHITE-Blue	GREY
26	RED-Blue	BLUE
27	RED-Blue	ORANGE
28	RED-Blue	GREEN
29	RED-Blue	BROWN
30	RED-Blue	GREY
31	BLUE-Black	BLUE
32	BLUE-Black	ORANGE
33	BLUE-Black	GREEN
34	BLUE-Black	BROWN
35	BLUE-Black	GREY
36	YELLOW-Blue	BLUE
37	YELLOW-Blue	ORANGE
38	YELLOW-Blue	GREEN
39	YELLOW-Blue	BROWN
40	YELLOW-Blue	GREY
41	WHITE-Orange	BLUE
42	WHITE-Orange	ORANGE
43	WHITE-Orange	GREEN
44	WHITE-Orange	BROWN
45	WHITE-Orange	GREY
46	ORANGE-Red	BLUE
47	ORANGE-Red	ORANGE
48	ORANGE-Red	GREEN
49	ORANGE-Red	BROWN
50	ORANGE-Red	GREY

* 2 pair in quad formation: Blue, Green, orange and Brown

IDENTIFICATION OF PAIRS: two pair, unscreened or collectively screened cables shall be cabled in quad formation and colour coded in clockwise order or rotation: black, blue, green, brown

IDENTIFICATION OF CORE: Up to 40 cores: all cores yellow and identified 1 to 40 both printed numbers and written word in black eg 10 core would be coloured yellow and identified by number "10, TEN" in black 41 to 80 cores: all cores black and identified 1 to 40 both printed numbers and written word in yellow eg 50 core would be coloured black and identified by number "10, TEN" in yellow

PAIR IDENTIFICATION: unscrende pairs shall be identified by means of coloured insulation in the sequence in the table, starting at the centre.

Screened pairs shall be identified either:

- by means of coloured insulation in the sequence in the table, starting at the centre or
- by a numbered polyester film which shall also serve as part of the screen insulation, in which case each pair in the cable shall have one black and one blue core.

NOTE: except in the case of bi-colour extrusion the colour indicated by the block letters is known as the base colour, and is

- the extruded colour
- the colour with the grater are of exposure on finished wire.

COLOUR CODE

COLOR CODE US I

Core.no	Basic color	1 st ring	2nd ring
1	BLACK	-	-
2	WHITE	-	-
3	RED	-	-
4	GREEN	-	-
5	BROWN	-	-
6	BLUE	-	-
7	ORANGE	-	-
8	YELLOW	-	-
9	VIOLET	-	-
10	GRAY	-	-
11	PINK	-	-
12	BEIGE	-	-

COLOUR CODE

COLOR CODE US2

Comparable with IEEE 1580 table 22 and K1 color code (for multi-conductor cables and per ICEA and NEC code)

Core. no	Basic color	1 st stripe	2nd stripe
1	BLACK	-	-
2	WHITE	-	-
3	RED	-	-
4	GREEN	-	-
5	ORANGE	-	-
6	BLUE	-	-
7	WHITE	BLACK	-
8	RED	BLACK	-
9	GREEN	BLACK	-
10	ORANGE	BLACK	-
11	BLUE	BLACK	-
12	BLACK	WHITE	-
13	RED	WHITE	-
14	GREEN	WHITE	-
15	BLUE	WHITE	-
16	BLACK	RED	-
17	WHITE	RED	-
18	ORANGE	RED	-
19	BLUE	RED	-
20	RED	GREEN	-
21	ORANGE	GREEN	-
22	BLACK	WHITE	RED
23	WHITE	BLACK	RED
24	RED	BLACK	WHITE
25	GREEN	BLACK	WHITE
26	ORANGE	BLACK	WHITE
27	BLUE	BLACK	WHITE
28	BLACK	RED	GREEN
29	WHITE	RED	GREEN
30	RED	BLACK	GREEN
31	GREEN	BLACK	ORANGE
32	ORANGE	BLACK	GREEN
33	BLUE	WHITE	ORANGE
34	BLACK	WHITE	ORANGE
35	WHITE	RED	ORANGE
36	ORANGE	WHITE	BLUE
37	WHITE	RED	BLUE
38	BLACK	WHITE	GREEN
39	WHITE	BLACK	GREEN
40	RED	WHITE	GREEN
41	GREEN	WHITE	BLUE
42	ORANGE	RED	GREEN

COLOUR CODE

Core. no	Basic color	1 st stripe	2nd stripe
43	BLUE	RED	GREEN
44	BLACK	WHITE	BLUE
45	WHITE	BLACK	BLUE
46	RED	WHITE	BLUE
47	GREEN	ORANGE	RED
48	ORANGE	RED	BLUE
49	BLUE	RED	ORANGE
50	BLACK	ORANGE	RED
51	WHITE	BLACK	ORANGE
52	RED	ORANGE	BLACK
53	GREEN	RED	BLUE
54	ORANGE	BLACK	BLUE
55	BLUE	BLACK	ORANGE
56	BLACK	ORANGE	GREEN
57	WHITE	ORANGE	GREEN
58	RED	ORANGE	GREEN
59	GREEN	BLACK	BLUE
60	ORANGE	GREEN	BLUE
61	BLUE	GREEN	ORANGE
62	BLACK	RED	BLUE
63	WHITE	ORANGE	BLUE
64	RED	BLACK	BLUE
65	GREEN	ORANGE	BLUE
66	ORANGE	WHITE	RED
67	BLUE	WHITE	RED
68	BLACK	GREEN	BLUE
69	WHITE	GREEN	BLUE
70	RED	GREEN	BLUE
71	GREEN	WHITE	RED
72	ORANGE	RED	BLACK
73	BLUE	RED	BLACK
74	BLACK	ORANGE	BLUE
75	RED	ORANGE	BLUE
76	GREEN	RED	BLACK
77	ORANGE	WHITE	GREEN
78	BLUE	WHITE	GREEN
79	RED	WHITE	ORANGE
80	GREEN	WHITE	ORANGE
81	BLUE	BLACK	GREEN
82	ORANGE	WHITE	-
83	GREEN	RED	-
84	BLACK	GREEN	-
85	WHITE	GREEN	-
86	BLUE	GREEN	-
87	BLACK	ORANGE	-
88	WHITE	ORANGE	-
89	RED	ORANGE	-
90	GREEN	ORANGE	-
91	BLUE	ORANGE	-
92	BLACK	BLUE	-

COLOUR CODE

COLOR CODE US 3

Core. no	Basic color	Color combination
1	BLACK	PAIRED WITH RED
2	BLACK	PAIRED WITH WHITE
3	BLACK	PAIRED WITH GREEN
4	BLACK	PAIRED WITH BLUE
5	BLACK	PAIRED WITH YELLOW
6	BLACK	PAIRED WITH BROWN
7	BLACK	PAIRED WITH ORANGE
8	RED	PAIRED WITH WHITE
9	RED	PAIRED WITH GREEN
10	RED	PAIRED WITH BLUE
11	RED	PAIRED WITH YELLOW
12	RED	PAIRED WITH BROWN
13	RED	PAIRED WITH ORANGE
14	GREEN	PAIRED WITH WHITE
15	GREEN	PAIRED WITH BLUE
16	GREEN	PAIRED WITH YELLOW
17	GREEN	PAIRED WITH BROWN
18	GREEN	PAIRED WITH ORANGE
19	WHITE	PAIRED WITH BLUE
20	WHITE	PAIRED WITH YELLOW
21	WHITE	PAIRED WITH BROWN
22	WHITE	PAIRED WITH ORANGE
23	BLUE	PAIRED WITH YELLOW
24	BLUE	PAIRED WITH BROWN
25	BLUE	PAIRED WITH ORANGE
26	BROWN	PAIRED WITH YELLOW
27	BROWN	PAIRED WITH ORANGE
28	ORANGE	PAIRED WITH YELLOW
29	VIOLET	PAIRED WITH ORANGE
30	VIOLET	PAIRED WITH RED
31	VIOLET	PAIRED WITH WHITE
32	VIOLET	PAIRED WITH GREEN
33	VIOLET	PAIRED WITH BLUE
34	VIOLET	PAIRED WITH YELLOW
35	VIOLET	PAIRED WITH BROWN
36	VIOLET	PAIRED WITH BLACK
37	GRAY PAIRED WITH WHITE	

COLOUR CODE

COLOR CODE US 4

Core. no	Basic color	1 st ring	2nd ring
1	BLACK		
2	BROWN		
3	RED		
4	ORANGE		
5	YELLOW		
6	GREEN		
7	BLUE		
8	VIOLET		
9	GRAY		
10	WHITE		
11	WHITE	BLACK	
12	WHITE	BROWN	
13	WHITE	RED	
14	WHITE	ORANGE	
15	WHITE	YELLOW	
16	WHITE	GREEN	
17	WHITE	BLUE	
18	WHITE	VIOLET	
19	WHITE	GRAY	
20	WHITE	BLACK	BROWN
21	WHITE	BLACK	RED
22	WHITE	BLACK	ORANGE
23	WHITE	BLACK	YELLOW
24	WHITE	BLACK	GREEN
25	WHITE	BLACK	BLUE
26	WHITE	BLACK	VIOLET
27	WHITE	BLACK	GRAY
28	WHITE	BLACK	RED
29	WHITE	BROWN	ORANGE
30	WHITE	BROWN	YELLOW
31	WHITE	BROWN	GREEN
32	WHITE	BROWN	BLUE
33	WHITE	BROWN	VIOLET
34	WHITE	BROWN	GRAY
35	WHITE	RED	ORANGE
36	WHITE	RED	YELLOW
37	WHITE	RED	GREEN
38	WHITE	RED	BLUE
39	WHITE	RED	VIOLET
40	WHITE	RED	GRAY
41	WHITE	ORANGE	YELLOW
42	WHITE	ORANGE	GREEN
43	WHITE	ORANGE	BLUE
44	WHITE	ORANGE	VIOLET
45	WHITE	ORANGE	GRAY
46	WHITE	YELLOW	GREEN
47	WHITE	YELLOW	BLUE
48	WHITE	YELLOW	VIOLET
49	WHITE	YELLOW	GRAY
50	WHITE	GREEN	BLUE
51	WHITE	GREEN	VIOLET
52	WHITE	GREEN	GRAY
53	WHITE	BLUE	VIOLET
54	WHITE	BLUE	GRAY
55	WHITE	VIOLET	GRAY

COLOUR CODE

COLOR CODE US 5

Core. no	Color combination
1	BLACK PAIRED WITH RED
2	BLACK PAIRED WITH WHITE
3	BLACK PAIRED WITH GREEN
4	BLACK PAIRED WITH BLUE
5	BLACK PAIRED WITH BROWN
6	BLACK PAIRED WITH YELLOW
7	BLACK PAIRED WITH ORANGE
8	RED PAIRED WITH GREEN
9	RED PAIRED WITH WHITE
10	RED PAIRED WITH BLUE
11	RED PAIRED WITH YELLOW
12	RED PAIRED WITH BROWN
13	RED PAIRED WITH ORANGE
14	GREEN PAIRED WITH BLUE
15	GREEN PAIRED WITH WHITE
16	GREEN PAIRED WITH BROWN
17	GREEN PAIRED WITH ORANGE
18	GREEN PAIRED WITH YELLOW
19	WHITE PAIRED WITH BLUE
20	WHITE PAIRED WITH BROWN
21	WHITE PAIRED WITH ORANGE
22	WHITE PAIRED WITH YELLOW
23	BLUE PAIRED WITH BROWN
24	BLUE PAIRED WITH BROWN
25	BLUE PAIRED WITH YELLOW
26	BROWN PAIRED WITH ORANGE
27	BROWN PAIRED WITH YELLOW
28	VIOLET PAIRED WITH RED
29	VIOLET PAIRED WITH WHITE
30	VIOLET PAIRED WITH GREEN
31	VIOLET PAIRED WITH BLUE
32	VIOLET PAIRED WITH BROWN
33	VIOLET PAIRED WITH YELLOW
34	VIOLET PAIRED WITH ORANGE
35	VIOLET PAIRED WITH GRAY
36	VIOLET PAIRED WITH BLACK
37	GRAY PAIRED WITH RED
38	GRAY PAIRED WITH WHITE
39	GRAY PAIRED WITH GREEN
40	GRAY PAIRED WITH BLUE
41	GRAY PAIRED WITH BROWN
42	GRAY PAIRED WITH YELLOW
43	GRAY PAIRED WITH ORANGE
44	GRAY PAIRED WITH BLACK
45	WHITE/BLACK PAIRED WITH RED
46	WHITE/BLACK PAIRED WITH GREEN
47	WHITE/BLACK PAIRED WITH BLUE
48	WHITE/BLACK PAIRED WITH BROWN
49	WHITE/BLACK PAIRED WITH YELLOW
50	WHITE/BLACK PAIRED WITH ORANGE
51	WHITE/BLACK PAIRED WITH VIOLET

COLOUR CODE

K2 Color code (with printed numbers)

Chart 12: ICEA S-66-524 NEMA WC-7

Core. no	Basic color	Stripe
1	BLACK	-
2	RED	-
3	BLUE	-
4	ORANGE	-
5	YELLOW	-
6	BROWN	-
7	RED	BLACK
8	BLUE	BLACK
9	ORANGE	BLACK
10	YELLOW	BLACK
11	BROWN	BLACK
12	BLACK	RED
13	BLUE	RED
14	ORANGE	RED
15	YELLOW	RED
16	BROWN	RED
17	BLACK	BLUE
18	RED	BLUE
19	ORANGE	BLUE
20	YELLOW	BLUE
21	BROWN	BLUE
22	BLACK	ORANGE
23	RED	ORANGE
24	BLUE	ORANGE
25	YELLOW	ORANGE
26	BROWN	ORANGE
27	BLACK	YELLOW
28	RED	YELLOW
29	BLUE	YELLOW
30	ORANGE	YELLOW
31	BROWN	YELLOW
32	BLACK	BROWN
33	RED	BROWN
34	BLUE	BROWN
35	ORANGE	BROWN
36	YELLOW	BROWN

COLOUR CODE













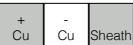
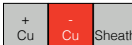

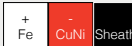



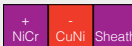
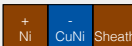
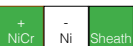

ICEA Table E2 (acc. to ICEA S-73-532)

Core.no	Basic color	Tracer
1	BLACK	-
2	RED	-
3	BLUE	-
4	ORANGE	-
5	YELLOW	-
6	BROWN	-
7	RED	BLACK
8	BLUE	BLACK
9	ORANGE	BLACK
10	YELLOW	BLACK
11	BROWN	BLACK
12	BLACK	RED
13	BLUE	RED
14	ORANGE	RED
15	YELLOW	RED
16	BROWN	RED
17	BLACK	BLUE
18	RED	BLUE
19	ORANGE	BLUE
20	YELLOW	BLUE
21	BROWN	BLUE
22	BLACK	ORANGE
23	RED	ORANGE
24	BLUE	ORANGE
25	YELLOW	ORANGE
26	BROWN	ORANGE
27	BLACK	YELLOW
28	RED	YELLOW
29	BLUE	YELLOW
30	ORANGE	YELLOW
31	BROWN	YELLOW
32	BLACK	BROWN
33	RED	BROWN
34	BLUE	BROWN
35	ORANGE	BROWN
36	YELLOW	BROWN

Pair cables are Black, Red and numbered. Triad cables are Black, Red, Blue and numbered.
Colors repeat after 36 conductors. There are no Green or White conductors stripes.

COLOUR CODE

Standard for Thermocouples Extension and Compensating Cables









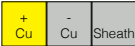

Type/Material	IEC 60584 ⁽¹⁾	ANSI MC 96.1	BS 4937 ed.74 - BS 1843
R + Platinum/13% Rhodium - Platinum	RCA/SCA Copper/Copper-Nickel Cl. 1: Cl. 2: $\pm 30 \mu V (\pm 2,5^{\circ}C)$ 0 ÷ +100°C		
S + Platinum/10% Rhodium - Platinum	RCA/SCB Copper/Copper-Nickel Cl. 1: Cl. 2: $\pm 60 \mu V (\pm 5^{\circ}C)$ 0 ÷ +200°C 	SX Copper/Copper-Nickel $\pm 57 \mu V (\pm 5^{\circ}C)$ 0 ÷ +200°C 	RX/SX Copper/Copper-Nickel $\pm 3^{\circ}C$ 0 ÷ +200°C 
B + Platinum/6% Rhodium - Platinum	BC Copper/Copper $-40 \mu V (-3,5^{\circ}C)$ 0 ÷ +100°C 	BX Copper/Copper $-57 \mu V (-3,7^{\circ}C)$ 0 ÷ +100°C 	
J + Iron - Copper-Nickel	JX Iron/Copper-Nickel Cl. 1: $\pm 85 \mu V (\pm 1,5^{\circ}C)$ Cl. 2: $\pm 140 \mu V (\pm 2,5^{\circ}C)$ $-25 \div +200^{\circ}C$ 	JX Iron/Copper-Nickel Special: $\pm 1,1^{\circ}C$ Standard: $\pm 2,2^{\circ}C$ 0 ÷ +200°C 	JX Iron/Copper-Nickel $\pm 3^{\circ}C$ 0 ÷ +200°C 
T + Copper - Copper-Nickel	TX Copper/Copper-Nickel Cl. 1: $\pm 30 \mu V (\pm 0,5^{\circ}C)$ Cl. 2: $\pm 60 \mu V (\pm 1,0^{\circ}C)$ $-25 \div +100^{\circ}C$ 	TX Copper/Copper-Nickel Special: $\pm 0,5^{\circ}C$ Standard: $\pm 1,0^{\circ}C$ 0 ÷ +100°C 	TX Copper/Copper-Nickel $\pm 1^{\circ}C$ 0 ÷ +200°C 
E + Nickel-Chromium - Copper-Nickel	EX Nickel-Chromium/Copper-Nickel Cl. 1: $\pm 120 \mu V (\pm 1,5^{\circ}C)$ Cl. 2: $\pm 200 \mu V (\pm 2,5^{\circ}C)$ $-25 \div +200^{\circ}C$ 	EX Nickel-Chromium/Copper-Nickel Special: - Standard: $\pm 1,7^{\circ}C$ 0 ÷ +200°C 	EX Nickel-Chromium/Copper-Nickel $\pm 1^{\circ}C$ $-25 \div +100^{\circ}C$ 
K + Nickel-Chromium - Nickel	KX Nickel-Chromium/Nickel Cl. 1: $\pm 60 \mu V (\pm 1,5^{\circ}C)$ Cl. 2: $\pm 105 \mu V (\pm 2,5^{\circ}C)$ $-25 \div +200^{\circ}C$ 	KX Nickel-Chromium/Nickel Special: - Standard: $\pm 2,2^{\circ}C$ 0 ÷ +200°C 	KX Nickel-Chromium/Nickel $\pm 3^{\circ}C$ 0 ÷ +200°C 
K + Nickel-Chromium - Nickel	KCB Copper/Copper-Nickel Cl. 1: - Cl. 2: $\pm 100 \mu V (\pm 2,5^{\circ}C)$ 0 ÷ +100°C 	VX⁽²⁾ Copper/Copper-Nickel Special: - Standard: $\pm 2,2^{\circ}C$ 0 ÷ +100°C 	VX Copper/Copper-Nickel $\pm 3^{\circ}C$ 0 ÷ +200°C 
K + Nickel-Chromium - Nickel	KCA Iron/Copper-Nickel Cl. 1: - Cl. 2: $\pm 100 \mu V (\pm 2,5^{\circ}C)$ 0 ÷ +150°C 	WX⁽²⁾ Iron/Copper-Nickel Special: - Standard: $\pm 3,3^{\circ}C$ 0 ÷ +200°C 	
N + Nickel-Chromium-Silica - Nickel-Silica	NX Nickel-Chromium-Silica/Nickel-Silica Cl. 1: $\pm 60 \mu V (\pm 1,5^{\circ}C)$ Cl. 2: $\pm 100 \mu V (\pm 2,5^{\circ}C)$ $-25 \div +200^{\circ}C$ 		
	NC Nickel-Chromium/Copper-Nickel Cl. 1: - Cl. 2: $\pm 100 \mu V (\pm 2,5^{\circ}C)$ 0 ÷ +150°C 		
U + Copper - Copper-Nickel			
U + Copper - Copper-Nickel			

1) Standard IEC 60584 is equivalent to standard: CEI 65-20, DIN IEC 60584, BS 4937,-30 ed.1993

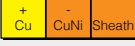
2) Specified to ISA RP 1.1 ed.1950.

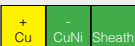















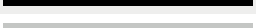

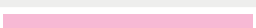
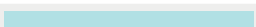



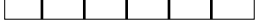

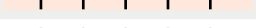





3) Specified to ANSI C 96.1 ed.1969

COLOUR CODE

NF C 42-324	DIN 43710	Electrical Characteristics (approx. values)				
		Size (AWG)	Stranding (N°/mm)	Cond. Resistance (Ω /km at 20°C)		Inductance (mH/km)
				+	-	
SC Copper/Copper-Nickel $\pm 7,0^\circ\text{C}$ $-25\div+200^\circ\text{C}$ 	SoPtRh/SoPt Copper/Copper-Nickel (RX/SX) $\pm 3,0^\circ\text{C}$ $0\div+200^\circ\text{C}$ 	20	1/0,81	35	233	1
		20	7/0,32	35	220	1
		18	1/1,02	22	147	1
		18	10/0,32	23	154	1
		16	1/1,29	14	92	1
		16	16/0,32	15	96	1
BC Copper/Copper $\pm 4,0^\circ\text{C}$ $-25\div+200^\circ\text{C}$ 		20	1/0,81	35	35	1
		20	7/0,32	35	35	1
		18	1/1,02	22	22	1
		18	10/0,32	23	23	1
		16	1/1,29	14	14	1
		16	16/0,32	15	15	1
JX/JC Iron/Copper-Nickel JX: $-25\div+250^\circ\text{C} \pm 1,5^\circ\text{C}$ JC: $-25\div+250^\circ\text{C} \pm 3,0^\circ\text{C}$ 	See LX	20	1/0,81	253	951	6
		20	7/0,32	240	897	6
		18	1/1,02	160	600	6
		18	10/0,32	168	628	6
		16	1/1,29	100	375	6
		16	16/0,32	103	393	6
TX/TC Copper/Copper-Nickel TX: $-25\div+250^\circ\text{C} \pm 0,5^\circ\text{C}$ TC: $-25\div+150^\circ\text{C} \pm 1,0^\circ\text{C}$ 	See UX	20	1/0,81	35	951	1
		20	7/0,32	35	897	1
		18	1/1,02	22	600	1
		18	10/0,32	23	628	1
		16	1/1,29	14	375	1
		16	16/0,32	15	393	1
EX/EC Nickel-Chromium/Copper-Nickel EX: $-25\div+250^\circ\text{C} \pm 1,5^\circ\text{C}$ EC: $-25\div+250^\circ\text{C} \pm 3,0^\circ\text{C}$ $-25\div+100^\circ\text{C}$ 		20	1/0,81	1370	951	4
		20	7/0,32	1292	897	4
		18	1/1,02	865	600	4
		18	10/0,32	905	628	4
		16	1/1,29	540	375	4
		16	16/0,32	565	393	4
KX/KC Nickel-Chromium/Copper-Nickel KX: $-25\div+250^\circ\text{C} \pm 1,5^\circ\text{C}$ KC: $-25\div+200^\circ\text{C} \pm 3,0^\circ\text{C}$ 	NiCr/Ni Nickel-Chromium/Nickel (KX) $\pm 3^\circ\text{C}$ $0\div+200^\circ\text{C}$ 	20	1/0,81	1370	567	4
		20	7/0,32	1292	535	4
		18	1/1,02	865	358	4
		18	10/0,32	905	375	4
		16	1/1,29	540	225	4
		16	16/0,32	565	235	4
VC Copper/Copper-Nickel $\pm 3^\circ\text{C}$ $-25\div+100^\circ\text{C}$ 		20	1/0,81	35	951	1
		20	7/0,32	35	897	1
		18	1/1,02	22	600	1
		18	10/0,32	23	628	1
		16	1/1,29	14	375	1
		16	16/0,32	15	393	1
WC Iron/Copper-Nickel $\pm 3^\circ\text{C}$ $-25\div+200^\circ\text{C}$ 	SoNiCr/SoNi Iron/Copper-Nickel (WX) $\pm 3^\circ\text{C}$ $0\div+200^\circ\text{C}$ 	20	1/0,81	253	1010	6
		20	7/0,32	240	952	6
		18	1/1,02	160	637	6
		18	10/0,32	168	666	6
		16	1/1,29	100	398	6
		16	16/0,32	103	417	6
		20	1/0,81	1940	708	4
		20	7/0,32	1776	648	4
		18	1/1,02	1224	446	4
		18	10/0,32	1243	454	4
		16	1/1,29	765	279	4
		16	16/0,32	777	284	4
	Cu/CuNi Copper/Copper-Nickel (UX) $\pm 3^\circ\text{C}$ $0\div+200^\circ\text{C}$ 	20	1/0,81	35	951	1
		20	7/0,32	35	897	1
		18	1/1,02	22	600	1
		18	10/0,32	23	628	1
		16	1/1,29	14	375	1
		16	16/0,32	15	393	1
	Fe/CuNi Iron/Copper-Nickel (LX) $\pm 3^\circ\text{C}$ $0\div+200^\circ$ 	20	1/0,81	253	951	6
		20	7/0,32	240	897	6
		18	1/1,02	160	600	6
		18	10/0,32	168	628	6
		16	1/1,29	100	375	6
		16	16/0,32	103	393	6

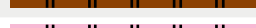
COLOUR CODE

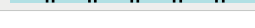
DIN VDE 0888-3, IEC 60304: Color code for fibers in loose tubes of standard optical cables

Fiber. no	Color	
01	RED	
02	GREEN	
03	YELLOW	
04	BLUE	
05	WHITE	
06	VIOLET	
07	ORANGE	
08	BLACK	
09	GREY	
10	BROWN	
11	PINK	
12	TURQUOISE	
13	RED/BLACK	
14	GREEN/BLACK	
15	YELLOW/BLACK	
16	BLUE/BLACK	
17	WHITE/BLACK	
18	VIOLET/BLACK	
19	ORANGE/BLACK	
20	NATURAL/BLACK	
21	GREY/BLACK	
22	BROWN/BLACK	
23	PINK/BLACK	
24	TURQUOISE/BLACK	
25	RED/BLACK/BLACK	
26	GREEN/BLACK/BLACK	
27	YELLOW/BLACK/BLACK	
28	BLUE/BLACK/BLACK	
29	WHITE/BLACK/BLACK	
30	VIOLET/BLACK/BLACK	
31	ORANGE/BLACK/BLACK	
32	NATURAL/BLACK/BLACK	
33	GREY/BLACK/BLACK	
34	BROWN/BLACK/BLACK	
35	PINK/BLACK/BLACK	
36	TURQUOISE/BLACK/BLACK	















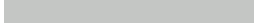





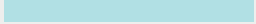

The first color is the basic color of the fiber, the second and third are applied as ring on the fiber

For optical cables with stranded units the following colors are used:

1. Unit	RED (counting unit)	
02	GREEN (direction unit)	
03	all other units have natural color	
04	blinds are black	











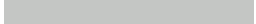

COLOUR CODE

TIA 598: Color code for fibers in loose tubes and tight-buffered optical cables

Fiber. no	Color	
01	BLUE	
02	ORANGE	
03	GREEN	
04	BROWN	
05	GREY	
06	WHITE	
07	RED	
08	BLACK	
09	YELLOW	
10	VIOLET	
11	PINK	
12	TURQUOISE	
13	BLUE/BLACK	
14	ORANGE/BLACK	
15	GREEN/BLACK	
16	BROWN/N/BLACK	
17	GREY/BLACK	
18	WHITE/BLACK	
19	RED/BLACK	
20	BLACK/BLACK	
21	YELLOW/BLACK	
22	VIOLET/BLACK	
23	PINK/BLACK	
24	TURQUOISE/BLACK	

The first color is the basic color of the fiber, the second is applied as ring on the fiber

TIA 598: Color code for loose tubes of standard optical cables

Tubes. no	Color	
01	BLUE	
02	ORANGE	
03	GREEN	
04	BROWN	
05	GREY	
06	WHITE	
07	RED	
08	BLACK	
09	YELLOW	
10	VIOLET	
11	PINK	
12	TURQUOISE	

Identification tubes clockwise direction

LOW VOLTAGE CURRENT CARRYING CAPACITY

Acc. to IEC 60364-5-52 table A.52-10 and B.52.14 (acc. to VDE 0298 T4 08/03)

Current carrying capacities in amperes and Correction factors for ambient air temperature other than 30°C

PVC insulation / Copper conductor 70°C

Conductor temperature +70°C, Ambient temperature: +30°C

Installation methods - table A.52-1					
Nominal cross sectional area of conductor mm ²	Multi core cables		Single core cables		
	Three loaded conductors	Three loaded conductors trefoil	Three loaded conductors flat		
			Touching	Spaced	
				Horizontal	Vertical
1,5	18,5	-	-	-	-
2,5	25	-	-	-	-
4	34	-	-	-	-
6	43	-	-	-	-
10	60	-	-	-	-
16	80	-	-	-	-
25	101	110	114	146	130
35	126	137	143	181	162
50	153	167	174	219	197
70	196	216	225	281	254
95	238	264	275	341	311
120	276	308	321	396	362
150	319	356	372	456	419
185	364	409	427	521	480
240	430	485	507	615	569
300	497	561	587	709	659
400	-	656	689	852	795
500	-	749	789	982	920
600	-	855	905	1138	1070

Correction factors - table B.52.14.																		
Ambient temperature °C	10	15	20	25	30	35	40	45	50	55	60	65	70	75	80	85	90	95
Insulation material PVC	1,22	1,17	1,12	1,06	1	0,94	0,87	0,79	0,71	0,61	0,50	-	-	-	-	-	-	-

NOTE 1:
Circular conductors are assumed for sizes up to and including 16 mm².
Values for larger sizes relate to shaped conductors and may safely be applied to circular conductor

NOTE 2:
De is the external diameter of the cable

LOW VOLTAGE CURRENT CARRYING CAPACITY

Acc.to IEC 60364-5-52 table B.52-12 and B.52.14 (acc. to VDE 0298 T4 08/03)

Current carrying capacities in amperes and Correction factors for ambient air temperature other than 30°C

XLPE or HEPR insulation / Copper conductor

Conductor temperature +90°C, Ambient temperature: +30°C

Installation methods - table B.52-1					
Nominal cross sectional area of conductor mm ²	Multi core cables		Single core cables		
	Three loaded conductors	Three loaded conductors trefoil	Three loaded conductors flat		
			Touching	Spaced	
				Horizontal	Vertical
1,5	23	-	-	-	-
2,5	32	-	-	-	-
4	42	-	-	-	-
6	54	-	-	-	-
10	75	-	-	-	-
16	100	-	-	-	-
25	127	135	141	182	161
35	158	169	176	226	201
50	192	207	216	275	246
70	246	268	279	353	318
95	298	328	342	430	389
120	346	383	400	500	454
150	399	444	464	577	527
185	456	510	533	661	605
240	538	607	634	781	719
300	621	703	736	902	833
400	-	823	868	1085	1008
500	-	946	998	1253	1169
600	-	1088	1151	1454	1362

Correction factors - table B.52.14.																		
Ambient temperature °C	10	15	20	25	30	35	40	45	50	55	60	65	70	75	80	85	90	95
Insulation material XLPE or HEPR	1,15	1,12	1,08	1,04	1	0,96	0,91	0,87	0,82	0,76	0,71	0,65	0,58	0,50	0,41	-	-	-

NOTE 1:
Circular conductors are assumed for sizes up to and including 16 mm².
Values for larger sizes relate to shaped conductors and may safely be applied to circular conductor

NOTE 2:
De is the external diameter of the cable

LOW VOLTAGE PHASE SPLITTING - RESISTANCE AND REACTANCE

PHASE SPLITTING

Single core cables laying in line

Cables laying in trefoil formation

Number 3 core units in the same layer									
2			3			4			
T	T		T	T	T	T	T	T	T
RS	SR		RS	SR	RS	RS	SR	RS	SR

Cables laying in line horizontally or vertically

Number 3 core units in the same layer(*)							
2				4			
RST		TSR		RST		TSR	

(*) For cables installed in layers, the indicated arrangements are repeated for each layer

RESISTANCE AND REACTANCE

Cables insulated with thermoplastic compounds

Apparent resistance of flexible red copper conductor at 70°C and reactance at 50 Hz (for 0,6/1 Kv voltage rates)

Power cables

Conductor cross-section (mm ²)	Resistance at 70 °C		Reactance at 50 Hz	
	c.c. / DC (Ohm/km)	c a. / AC (Ohm/km)	single cores (Ohm/km)	multi cores (Ohm/km)
1,5	15,9	15,9	0,147	0,106
2,5	9,55	9,55	0,186	0,098
4	5,92	5,92	0,129	0,097
6	3,95	3,95	0,121	0,092
10	2,29	2,29	0,111	0,086
16	1,45	1,45	0,103	0,081
25	0,93	0,93	0,097	0,080
35	0,66	0,66	0,093	0,077
50	0,46	0,46	0,090	0,076
70	0,33	0,33	0,086	0,074
95	0,25	0,25	0,085	0,074
120	0,193	0,194	0,081	-
150	0,154	0,156	0,081	-
185	0,127	0,129	0,081	-
240	0,096	0,099	0,080	-

LOW VOLTAGE RESISTANCE AND REACTANCE

Cables insulated with thermoplastic compounds

Control and signalling cables

number of conductors	conductor cross-section (mm ²)	resistance at 70 °C c.c / DC (Ohm/km)	c.c / DC (Ohm/km)	reactance at 50 Hz (Ohm/km)
5	1,5	15,9	15,9	0,106
7	1,5	15,9	15,9	0,106
7	2,5	9,55	9,55	0,098
from 10 to 19	1,5	16	16	0,106
from 10 to 19	2,5	9,65	9,65	0,098
24	1,5	16,1	16,1	0,106
24	2,5	9,7	9,7	0,098

Cables insulated with elastomeric compounds

Resistance at 70°C

Conductor cross-section (mm ²)	Fexible red copper conductor		Rigid red copper conductor	
	c.c. / DC (Ohm/km)	c.a. / AC (Ohm/km)	c.c. / DC (Ohm/km)	c.a. / AC (Ohm/km)
1,5	16,95	16,95	15,4	15,4
2,5	10,17	10,17	9,45	9,45
4	6,31	6,31	5,88	5,88
6	4,20	4,20	3,93	3,93
10	2,43	2,43	2,33	2,33
16	1,54	1,54	1,47	1,47
25	0,99	0,99	0,93	0,93
35	0,71	0,71	0,67	0,67
50	0,49	0,50	0,49	0,49
70	0,34	0,35	0,34	0,34
95	0,26	0,27	0,25	0,25
120	0,20	0,21	0,20	0,20
150	0,16	0,17	0,16	0,16
185	0,13	0,14	0,13	0,13
240	0,102	0,104	0,96	0,99
300	0,081	0,085	0,076	0,080
400	0,062	0,065	0,060	0,064
500	-	-	0,047	0,052
630	-	-	0,037	0,043

LOW VOLTAGE RESISTANCE AND REACTANCE - VOLTAGE DROP

Cables insulated with elastomeric compounds

Reactance at 50 Hz

Conductor cross-section (mm ²)	Rigid red copper conductor		Flexible red copper conductor	
	Single core (Ohm/km)	Multi cores (Ohm/km)	Single core (Ohm/km)	Multi cores (Ohm/km)
1,5	0,146	0,103	0,144	0,100
2,5	0,135	0,095	0,132	0,094
4	0,126	0,090	0,122	0,087
6	0,118	0,085	0,114	0,083
10	0,106	0,079	0,105	0,078
16	0,099	0,076	0,098	0,075
25	0,095	0,076	0,093	0,075
35	0,091	0,074	0,089	0,072
50	0,088	0,073	0,085	0,071
70	0,087	0,072	0,084	0,070
95	0,085	0,070	0,083	0,069
120	0,084	0,070	0,080	0,069
150	0,084	0,070	0,080	0,069
185	0,083	0,070	0,080	0,069
240	0,081	0,070	0,078	0,069
300	0,079	0,069	0,076	0,068
400	0,079	0,069	0,076	0,068
500	0,077	-	0,074	-
630	0,076	-	0,073	-

VOLTAGE DROP

For alternate currents, voltage drop is calculated (Volts) as follows:
$$\phi V = \frac{C_t \cdot I \cdot L}{1000}$$

Where:

C_t (V/A km) = $K \cdot (R \cdot \cos j + X \cdot \sin j)$

L (m) = length of line

I (A) = current

R (ohm/km) = conductor resistance at maximum operating temperature

X (ohm/km) = phase reactance

j = power factor

$K = 2$ for single-phase system

$K = 1,73$ for three-phase system

The formula is valid direct currents too

LOW VOLTAGE -VOLTAGE DROP

Voltage drop coefficients (Ct) in AC

Flexible PVC cables at 70 °C

Cross-section	single-phase system single core				three-phase system single core				single-phase system multi-core				three-phase system multi-core			
	cos φ 0,7	cos φ 0,8	cos φ 0,9	cos φ 1	cos φ 0,7	cos φ 0,8	cos φ 0,9	cos φ 1	cos φ 0,7	cos φ 0,8	cos φ 0,9	cos φ 1	cos φ 0,7	cos φ 0,8	cos φ 0,9	cos φ 1
1,5	22,49	25,63	28,77	31,83	19,45	22,17	24,89	27,53	22,43	25,59	28,73	31,83	19,40	22,1	24,86	27,53
2,5	13,56	15,43	17,30	19,10	11,73	13,35	14,97	16,52	13,50	15,39	17,27	19,10	11,68	13,31	14,94	16,52
4	8,47	9,63	10,77	11,84	7,33	8,33	9,32	10,25	8,43	9,59	10,74	11,84	7,29	8,30	9,29	10,25
6	5,70	6,46	7,21	7,90	4,93	5,59	6,24	6,83	5,66	6,43	7,19	7,90	4,89	5,56	6,22	6,83
10	3,36	3,79	4,21	4,57	2,90	3,28	3,64	3,95	3,32	3,76	4,19	4,57	2,87	3,25	3,62	3,95
16	2,17	2,44	2,69	2,90	1,88	2,11	2,33	2,50	2,14	2,41	2,69	2,90	1,85	2,09	2,31	2,50
25	1,45	1,61	1,76	1,87	1,25	1,39	1,53	1,61	1,42	1,59	1,74	1,87	1,23	1,37	1,51	1,61
35	1,06	1,17	1,27	1,33	0,29	1,01	1,10	1,15	1,04	1,15	1,26	1,33	0,90	1	1,09	1,15
50	0,77	0,85	0,91	0,92	0,67	0,73	0,79	0,80	0,76	0,83	0,90	0,92	0,65	0,72	0,78	0,80
70	0,58	0,62	0,66	0,65	0,50	0,54	0,57	0,56	0,56	0,61	0,65	0,65	0,49	0,53	0,56	0,56
95	0,47	0,50	0,52	0,50	0,41	0,43	0,45	0,43	-	-	-	-	0,39	0,42	0,44	0,43
120	0,39	0,41	0,42	0,39	0,34	0,34	0,36	0,34	-	-	-	-	-	-	-	-
150	0,34	0,35	0,35	0,31	0,29	0,30	0,30	0,27	-	-	-	-	-	-	-	-
185	0,30	0,30	0,30	0,26	0,26	0,26	0,26	0,22	-	-	-	-	-	-	-	-
240	0,25	0,25	0,25	0,20	0,22	0,22	0,21	0,17	-	-	-	-	-	-	-	-

Flexible HEPR cables at 90 °C

Cross-section	single-phase system single core				three-phase system single core				single-phase system multi-core				three-phase system multi-core			
	cos φ 0,7	cos φ 0,8	cos φ 0,9	cos φ 1	cos φ 0,7	cos φ 0,8	cos φ 0,9	cos φ 1	cos φ 0,7	cos φ 0,8	cos φ 0,9	cos φ 1	cos φ 0,7	cos φ 0,8	cos φ 0,9	cos φ 1
1,5	23,95	27,31	30,65	33,92	20,71	23,62	26,51	29,34	23,88	27,25	30,61	33,92	20,66	23,57	26,48	29,34
2,5	14,43	16,44	18,43	20,35	12,48	14,22	15,94	17,6	14,38	16,39	18,40	20,35	12,44	14,18	15,91	17,60
4	9,01	10,24	11,47	12,62	7,79	8,86	9,92	10,92	8,96	10,2	11,44	12,62	7,75	8,83	9,89	10,92
6	6,05	6,87	7,67	8,42	5,24	5,94	6,64	7,28	6,01	6,83	7,65	8,42	5,20	5,91	6,61	7,28
10	3,56	4,02	4,48	4,87	3,08	3,48	3,87	4,21	3,52	3,99	4,45	4,87	3,05	3,45	3,85	4,21
16	2,30	2,59	2,86	3,09	1,99	2,24	2,48	2,67	2,27	2,56	2,84	3,09	1,96	2,21	2,46	2,67
25	1,53	1,70	1,87	1,99	1,32	1,47	1,62	1,72	1,5	1,68	1,85	1,99	1,30	1,45	1,60	1,72
35	1,12	1,24	1,35	1,41	0,97	1,07	1,17	1,22	1,09	1,22	1,33	1,41	0,94	1,05	1,15	1,22
50	0,81	0,89	0,96	0,99	0,70	0,77	0,83	0,85	0,79	0,87	0,95	0,99	0,68	0,76	0,82	0,85
70	0,61	0,66	0,70	0,70	0,53	0,57	0,61	0,60	0,59	0,64	0,69	0,70	0,51	0,55	0,59	0,60
95	0,49	0,52	0,55	0,53	0,42	0,45	0,47	0,46	0,47	0,51	0,54	0,53	0,40	0,44	0,46	0,46
120	0,40	0,43	0,44	0,41	0,35	0,37	0,38	0,36	0,39	0,41	0,43	0,41	0,34	0,36	0,37	0,36
150	0,35	0,36	0,37	0,33	0,30	0,31	0,32	0,29	0,33	0,35	0,36	0,33	0,29	0,30	0,31	0,29
185	0,31	0,32	0,32	0,27	0,26	0,27	0,27	0,24	-	-	-	-	0,25	0,26	0,27	0,24
240	0,26	0,26	0,26	0,21	0,22	0,23	0,22	0,18	-	-	-	-	0,21	0,22	0,22	0,18
300	0,23	0,23	0,22	0,17	0,20	0,20	0,19	0,15	-	-	-	-	0,19	0,19	0,18	0,15
400	0,20	0,20	0,19	0,13	0,18	0,17	0,16	0,12	-	-	-	-	0,17	0,16	0,16	0,12
500	0,18	0,17	0,16	0,11	0,16	0,15	0,14	0,091	-	-	-	-	-	-	-	-
630	0,16	0,16	0,14	0,09	0,14	0,14	0,12	0,075	-	-	-	-	-	-	-	-

LOW VOLTAGE - SHORT-CIRCUIT

The protection devices must consider both the maximum and the minimum short-circuit currents reported below

MAXIMUM SHORT-CIRCUIT CURRENT

For alternate currents, voltage drop is calculated (Volts) as follows:
$$S \geq = \frac{I_{cc} \sqrt{T}}{C}$$

Therefore, the max short circuit current accepted by a conductor with section S is calculated with the following formula:
$$I_{cc} (\max) = \frac{S \cdot C}{\sqrt{T}}$$

Where:

T = short circuit duration (sec)

S = cross-section of copper conductor (mm²)

I_{cc} = short circuit current (A)

C = 115 for PVC copper cables (160 °C)

143 for G7 rubber copper cables (250 °C)

NOTE:

The formula above is valid for short time periods (a maximum of 5 sec.).

To calculate the effective short-circuit current allowed by the shield, see the CEI 64-8 standard, appendix D

C coefficient values for copper conductors are dependent on the temperature difference between start and end of short-circuit, acc. to the table 2.02.02 of the CEI 11-17 standard.

Starting temperature Θ _o °C	Ending temperature Θ _o °C					
	140	160	180	200	220	250
90	86	100	112	122	131	143
85	90	104	115	125	134	146
80	94	108	119	129	137	149
75	99	111	122	132	140	151
70	103	115	125	135	143	154
65	107	119	129	138	146	157
60	111	122	132	141	149	160
50	118	129	139	147	155	165
40	126	136	145	153	161	170
30	133	143	152	159	166	176

LOW VOLTAGE - SHORT-CIRCUIT

MINIMUM SHORT-CIRCUIT CURRENT

Minimum short-circuit current is considered during a short-circuit between phase and neutral (or between phase and phase, for a not distributed neutral), in the farthest point of the protected conduit. In case of a system powered by several origins, only one source must be taken into consideration the one corresponding to the minimum value.

The minimum short-circuit current can be calculated using the formulas a) and b), considering: a 50% of resistance increase at 20 °C, due to the conductors heating and a 80% of rated voltage reduction, due to the effect of the short-circuit on the current carrying capacities.

If the impedance of the incoming circuit is well-know, the coefficient 0,8 must be replaced by a specific value.

$$\text{a) } I_{cc} = \frac{0,8 U}{1,5 \rho \frac{2 L}{S}} \quad \text{b) } I_{cc} = \frac{0,8 U_0}{1,5 \rho (1+m) \frac{L}{S}}$$

a) for a neutral not distributed conductor, where:

U = line voltage supplied, linked rated voltage volts

ρ = resistivity of the conductor compounds at 20 °C, ohm • mm² (0,018 for copper - 0,027 for aluminium)

L = length of protected conductor, metres

S = conductor cross-section, mm²

I_{cc} = short-circuit current

b) for a neutral distributed conductor, where:

U₀ = phase rating voltage, voltsm









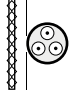

m = ratio of the neutral conductor resistance and the phase conductor resistance

(if they are composed of the same material, the ratio is the result between the phase conductor cross-section and the neutral conductor cross-section)

MEDIUM VOLTAGE CURRENT CARRYING CAPACITY

CURRENT CARRYING CAPACITY

Current carrying capacities in amperes and Correction factors for ambient air temperature other than 30°C

Cross-section mm ²	PVC insulation	Rubber up to 10 kV								
										
1	18,5	18	19	14	11	9	8	7	5	4
1,5	25	23	24	18	14	11	10	9	6	5
2,5	34	30	2	24	18	15	13	11	8	7
4	43	41	43	33	25	20	17	16	11	9
6	60	53	56	42	32	26	22	20	14	12
10	80	74	78	59	45	36	31	28	20	16
16	101	99	104	79	60	49	42	38	27	22
25	126	131	138	105	80	64	55	50	35	29
35	153	162	170	130	99	79	68	62	44	36
50	196	202	22	162	123	99	85	78	55	44
70	238	250	263	200	153	123	105	95	68	55
95	276	301	316	241	184	147	126	114	81	66
120	319	352	370	282	215	172	148	134	95	77
150	364	404	424	323	246	198	170	154	109	89
185	430	461	484	369	281	226	194	175	124	101
240	497	540	567	432	329	265	227	205	146	119
300	-	620	651	496	378	304	260	236	167	136
Rubber from 15 kV										
16	101	105	-	84	64	51	44	40	28	23
25	126	139	-	111	85	68	58	53	38	31
35	153	172	-	138	105	84	72	65	46	38
50	196	216	-	172	131	105	90	82	58	47
70	238	265	-	212	162	130	111	101	72	58
95	276	319	-	255	195	156	134	121	86	70
120	319	371	-	297	226	182	156	141	100	82
150	364	428	-	342	261	210	180	163	116	94
185	430	488	-	390	298	239	205	185	132	107
240	497	574	-	459	350	281	241	218	155	126
300	-	660	-	528	403	323	277	251	178	145

* The reduction factor is also valid for flat reeling cables (spirally)

Current carrying capacities in A are calculated according to the IEC 60287 standard.

They are calculated assuming the following values:

Ambient temperature for installation in open air : 30 °C

Ambient temperature for underground burial : 20 °

Laying depths: U = 3÷10 kV 0,8 m
 U = 15÷30 kV 1,0 m
 U = 45 kV 1,2 m

Metallic screens interconnected and grounded at both ends

MEDIUM VOLTAGE CORRECTION FACTORS

CORRECTION FACTORS

Insulation	Conductor temperature °C	Cables type	Ambient temperature °C											
			10	15	20	25	30	35	40	45	50	55	60	65
PVC	70	in air cables*	1,22	1,17	1,12	1,06	1	0,94	0,87	0,79	0,71	0,61	0,50	-
EPR / RUBBER	90	in air cables*	1,15	1,12	1,08	1,04	1	0,96	0,91	0,87	0,82	0,76	0,71	0,65
	90	buried cables	1,07	1,04	1	0,96	0,93	0,89	0,85	0,80	0,76	-	-	-

* Not directly exposed to the sun

THREE-CORE CABLES GROUNDED LAYING or single-core cables enclosed in trefoil

Number of cables or trefoil-set (horizontally)		2	3	4	6
Space between cables or trefoil-set	7 cm	0.84	0.74	0.67	0.60
	25 cm	0.86	0.78	0.74	0.69





THREE-CORE CABLES GROUNDED PIPE LAYING

Number of cables (horizontally)	1	2	3
	0.82	0.69	0.61



THREE-CORE CABLES LAYED IN AIR





Number of sets of three (horizontally)	1	2	3	6	9	
Single layer	0,95	0,9	0,88	0,85	0,84	
Layers number (vertical)	1	1	0,98	0,96	0,93	0,92
	2	1	0,95	0,93	0,9	0,89
	3	1	0,94	0,92	0,89	0,88
	6	1	0,93	0,9	0,87	0,86

Number of sets of three (vertical)	1	2	3	6	9
	1	0,93	0,9	0,87	0,86



Cables number (horizontally)	1	2	3	6	9	
Layers number (vertical)	1	0,95	0,84	0,8	0,75	0,73
	2	0,95	0,8	0,76	0,71	0,69
	3	0,95	0,78	0,74	0,7	0,68
	6	0,95	0,76	0,72	0,68	0,66

Cables number (horizontally)	1	2	3	6	9
	0,95	0,78	0,73	0,68	0,66



MEDIUM VOLTAGE CORRECTION FACTORS AND PHASE SPLITTING

SINGLE CORE TREFOIL CORES CABLES LAYED IN AIR

Number of sets of three (horizontally)		1	2	3	6	9
Single layer		0,95	0,9	0,88	0,85	0,84
Layers number (vertical)	1	1	0,98	0,96	0,93	0,92
	2	1	0,95	0,93	0,9	0,89
	3	1	0,94	0,92	0,89	0,88
	4	1	0,93	0,9	0,87	0,86

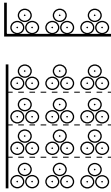

Number of sets of three (vertical)	1	2	3
	0,89	0,86	0,84

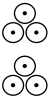

Number of single core (horizontally)		1	2	3
Single layer		0,92	0,89	0,88
Layers number (vertical)	1	1	0,97	0,96
	2	0,97	0,94	0,93
	3	0,96	0,93	0,92
	6	0,94	0,91	0,9

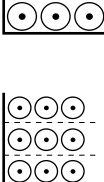

Number of single core (vertical)	1	2	3
	0,94	0,91	0,89



PHASE SPLITTING

Single core cables laying in line

Cables laying in trefoil formation

Number 3 core units in the same layer								
2			3			4		
T	T	T	T	T	T	T	T	T
RS	SR	RS	SR	RS	RS	SR	RS	SR

Cables laying in line horizontally or vertically

Number 3 core units in the same layer(*)			
2		4	
RST	TSR	RST	TSR

(*) For cables installed in layers, the indicated arrangements are repeated for each layer

MEDIUM VOLTAGE RESISTANCE

RESISTANCE

Cables insulated with elastomeric compounds

Apparent resistance of red copper conductor and aluminium at 90°C and at 50 Hz

Conductor cross-section (mm ²)	Single core cables (copper-aluminium conductor)								Single core cables (copper-aluminium conductor any rated voltage)		three core cables (copper-aluminium conductor any rated voltage)	
	1,8/3 kV - 3,6/6 kV (Ohm/km)		6/10 kV - 8,7/15 kV (Ohm/km)		12/20 kV - 18/30 kV (Ohm/km)		26/45 kV (Ohm/km)		(Ohm/km)		(Ohm/km)	
	Cu	Al	Cu	Al	Cu	Al	Cu	Al	Cu	Al	Cu	Al
10	2,33	3,91	2,33	3,91	-	-	-	-	2,33	3,91	2,33	3,91
16	1,47	2,47	1,47	2,47	-	-	-	-	1,47	2,47	1,47	2,47
25	0,92	1,56	0,929	1,56	0,929	1,56	-	-	0,929	1,56	0,929	1,56
35	0,67	1,12	0,671	1,13	0,671	1,13	-	-	0,67	1,13	0,669	1,12
50	0,495	0,832	0,495	0,832	0,495	0,832	-	-	0,495	0,832	0,494	0,83
70	0,347	0,583	0,344	0,58	0,344	0,58	0,344	0,58	0,344	0,58	0,343	0,57
95	0,248	0,416	0,248	0,416	0,248	0,416	0,248	0,416	0,248	0,416	0,247	0,415
120	0,198	0,333	0,198	0,333	0,198	0,333	0,198	0,333	0,198	0,333	0,196	0,329
150	0,161	0,27	0,161	0,27	0,161	0,27	0,161	0,27	0,161	0,27	0,160	0,269
185	0,130	0,218	0,130	0,218	0,130	0,218	0,130	0,218	0,130	0,218	0,129	0,217
240	0,0984	0,165	0,0983	0,165	0,0982	0,165	0,0981	0,165	0,1	0,168	0,1	0,168
300	0,0789	0,132	0,0788	0,132	0,0787	0,132	0,0786	0,132	0,081	0,136	0,08	0,134
400	0,0625	0,105	0,0624	0,105	0,0623	0,105	0,0622	0,105	0,065	0,109	0,065	0,109
500	0,0496	0,0833	0,0494	0,0830	0,0493	0,0828	0,0491	0,0825	0,053	0,0890	0,0536	0,09
630	0,0396	0,0665	0,0394	0,0662	0,0393	0,0662	0,0391	0,0657	0,044	0,0739	-	-

Insulation resistance per phase (MOhm/km)

Conductor cross-section (mm ²)	Nominal voltage						
	1,8/3 kV	3,6/6 kV	6/10 kV	8,7/15 kV	12/20 kV	18/30 kV	26/45 kV
10	1590	-	-	-	-	-	-
16	1360	1505	1645	1990	-	-	-
25	1140	1315	1445	1760	2130	-	-
35	995	1180	1300	1595	1830	2455	-
50	885	1075	1185	1460	1680	2155	-
70	755	945	1045	1300	1505	1950	2105
95	655	835	925	1155	1345	1760	1905
120	595	770	855	1070	1250	1645	1785
150	540	705	785	990	1160	1535	1665
185	485	645	720	910	1070	1420	1550
240	430	580	645	820	965	1295	1415
300	390	530	590	755	890	1200	1310
400	350	470	520	670	790	1070	1165
500	340	450	470	600	720	980	1065
630	330	400	420	540	650	890	970

MEDIUM VOLTAGE REACTANCE

REACTANCE

Single core cables phase reactance at 50 Hz

Conductor cross-section (mm ²)	Single core cables (average values)						
	1,8/3 kV (Ohm/km)	3,6/6 kV (Ohm/km)	6/10 kV (Ohm/km)	8,7/15 kV (Ohm/km)	12/20 kV (Ohm/km)	18/30 kV (Ohm/km)	26/45 kV (Ohm/km)
10	0,19	0,20	0,21	-	-	-	-
16	0,18	0,19	0,20	0,21	-	-	-
25	0,18	0,18	0,19	0,20	0,21	-	-
35	0,17	0,18	0,19	0,19	0,20	0,21	-
50	0,16	0,17	0,18	0,19	0,19	0,20	-
70	0,16	0,17	0,17	0,18	0,19	0,20	0,21
95	0,16	0,16	0,17	0,17	0,18	0,19	0,20
120	0,15	0,16	0,16	0,17	0,18	0,18	0,19
150	0,15	0,16	0,16	0,17	0,17	0,18	0,19
185	0,14	0,15	0,16	0,16	0,17	0,18	0,18
240	0,14	0,15	0,16	0,16	0,16	0,17	0,18
300	0,14	0,15	0,15	0,16	0,16	0,17	0,17
400	0,14	0,15	0,15	0,15	0,16	0,16	0,17
500	0,14	0,14	0,15	0,5	0,15	0,16	0,17
630	0,14	0,14	0,15	0,15	0,15	0,16	0,16

NOTE:

Valid both for copper and aluminium cables

Single core cables laying in trefoil formation phase reactance at 50 Hz

Conductor cross-section (mm ²)	Single core cables						
	1,8/3 kV (Ohm/km)	3,6/6 kV (Ohm/km)	6/10 kV (Ohm/km)	8,7/15 kV (Ohm/km)	12/20 kV (Ohm/km)	18/30 kV (Ohm/km)	26/45 kV (Ohm/km)
10	0,14	0,16	0,16	-	-	-	-
16	0,13	0,14	0,15	0,16	-	-	-
25	0,12	0,13	0,14	0,15	0,15	-	-
35	0,11	0,12	0,13	0,14	0,14	0,16	-
50	0,11	0,12	0,12	0,13	0,13	0,15	-
70	0,1	0,11	0,12	0,12	0,13	0,14	0,15
95	0,098	0,11	0,11	0,12	0,12	0,13	0,14
120	0,097	0,1	0,11	0,11	0,12	0,13	0,14
150	0,092	0,099	0,1	0,11	0,11	0,12	0,13
185	0,089	0,096	0,1	0,11	0,11	0,12	0,12
240	0,086	0,093	0,096	0,1	0,1	0,11	0,12
300	0,084	0,092	0,094	0,098	0,1	0,11	0,12
400	0,082	0,090	0,092	0,095	0,099	0,11	0,11
500	0,081	0,088	0,089	0,092	0,095	0,1	0,11
630	0,079	0,086	0,087	0,090	0,093	0,099	0,10

NOTE:

Valid both for copper and aluminium cables

MEDIUM VOLTAGE REACTANCE - SHORT CIRCUIT CURRENT CAPACITY

Three core cables phase reactance at 50 Hz

Conductor cross-section (mm ²)	Three core cables						
	1,8/3 kV (Ohm/km)	3,6/6 kV (Ohm/km)	6/10 kV (Ohm/km)	8,7/15 kV (Ohm/km)	12/20 kV (Ohm/km)	18/30 kV (Ohm/km)	26/45 kV (Ohm/km)
10	0,11	0,13	0,14	-	-	-	-
16	0,1	0,12	0,13	0,14	-	-	-
25	0,096	0,11	0,12	0,13	0,14	-	-
35	0,091	0,1	0,11	0,12	0,13	0,14	-
50	0,086	0,1	0,11	0,11	0,12	0,13	-
70	0,083	0,095	0,1	0,11	0,11	0,13	0,14
95	0,080	0,091	0,096	0,1	0,11	0,12	0,13
120	0,078	0,088	0,093	0,099	0,1	0,12	0,13
150	0,076	0,086	0,091	0,096	0,1	0,11	0,12
185	0,075	0,083	0,088	0,093	0,098	0,11	0,12
240	0,073	0,081	0,085	0,09	0,094	0,1	-
300	0,071	0,081	0,083	0,088	0,092	0,1	-
400	0,07	0,08	0,081	0,086	-	-	-
500	0,07	0,08	0,081	-	-	-	-

NOTE:

Valid both for copper and aluminium cables

MAX CURRENT CARRYING (kA) IN SHORT CIRCUIT

Conditions for duration 1 second and start temperature 90°C

Conductor	Sections-mm														
	10	15	25	35	50	70	95	120	150	185	240	300	400	500	630
Copper	1,4	2,3	3,6	5	7,1	10	14	17	21	26	34	43	57	72	90
Alluminium	0,92	1,5	2,3	3,2	4,6	6,4	8,7	11	14	17	22	28	37	46	58

MINIMUM BENDING RADIUS

Min. Bending Radii acc. to DIN VDE 0298 part. 3

Cables for fixed laying:				
Cable type:	Voltage up to 0,6/1 kV			Voltage above to 0,6/1 kV
	Outer diameter of cable or thickness of flat cables in mm			
	up to 10	above 10 up to 25	above 25	
Fixed laying:	4 x D*	4 x D	4 x D	6 x D
Single bended installation:	1 x D	2 x D	3 x D	4 x D

Flexible cables:					
Cable type:	Voltage up to 0,6/1 kV				Voltage above to 0,6/1 kV
	Outer diameter of cable or thickness of flat cables in mm				
	up to 8	above 8 up to 12	above 12 up to 20	above 20	
Fixed laying:	3 x D	3 x D	4 x D	4 x D	6 x D
Freely movable:	3 x D	4 x D	5 x D	5 x D	10 x D
Cable entry/gland	3 x D	4 x D	5 x D	5 x D	10 x D
Mechanical restraint ¹⁾					
Cable-drum mode	5 x D	5 x D	5 x D	6 x D	12 x D
Festoon mode:	3 x D	4 x D	5 x D	5 x D	10 x D
Drag-chain mode:	4 x D	4 x D	5 x D	5 x D	10 x D
Roller reversing:	7,5 x D	7,5 x D	7,5 x D	7,5 x D	15 x D

NOTES:

D* = Outer diameter of cable or thickness of flat cables

¹⁾ = Suitability for this application must be assured by means of special structural features

Please contact us in the case of cables types suitable for multiple application types

FLAMABILITY TEST

Examination of the vertical flame length, test method I kV - flame with gas/air mixture

Description	VDE 0482 part. 265-2-1, EN 50265-2-1 and IEC 60332-1	VDE 0482 part. 265-2-2, EN 50265-2-2 and IEC 60332-2
Length of specimen	600 mm	600 mm
Burner	Acc. to EN 60695-2-4-1	Acc. to VDE 0482 part. 265-1 and EN 50265-1
Test temperature	1 kW flame	Defined by the stipulated setting of the Flame length
Position of specimen	Vertical	Vertical
Position of flame	45° to vertical specimen	45° to vertical specimen
Duration of flame	See table 1	20 seconds
Conditions	Cable must be self-extinguishing. The damage or carbonization may only reach max. 50 mm under the upper fixing clamp.	Cable must be self-extinguishing. The damage or carbonization may only reach max. 10 mm under the upper fixing clamp.

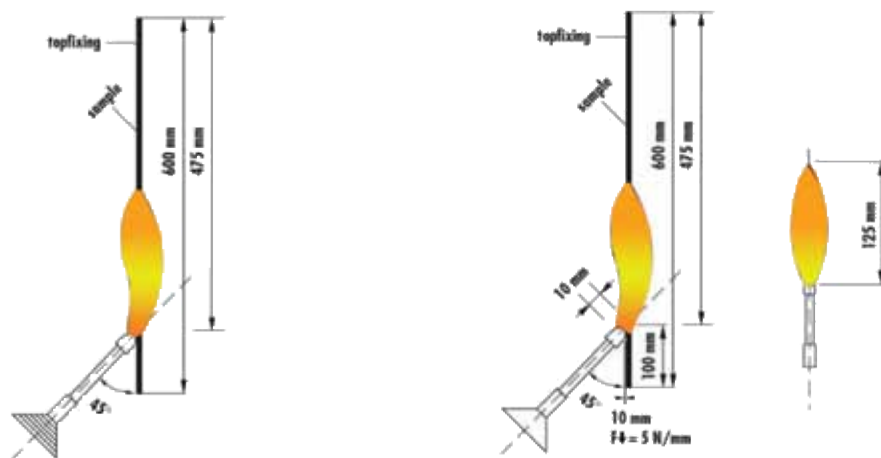

outer diameter *) of specimen in mm

Nominal value	outer diameter *) of specimen in mm
$D \leq 25$	60
$25 < D \leq 50$	120
$50 < D \leq$	240
$D > 75$	480

*) If cables or insulated cables are tested that are not round (e.g. flat twin cables) their dimensions are to be measured and an equivalent diameter must be calculated from this.

FLAMABILITY TEST

Description	UL 1581 section 1080 (VW-I Flame test)
Length of specimen	455 mm
Burner	Bunsen burner with additional air supply (Tirril-Gasburner) Ø 9,5 mm
Test temperature	500 W flame
Position of specimen	Vertical
Position of flame	20° to vertical specimen
Duration of flame	5 x 15 seconds with 15 seconds between each flaming
Conditions	Paper max. 25% carbonized. The specimen may keep on burning for max. 1 minute after any application. Material dropping must not ignite the cotton (B) lying under the specimen.

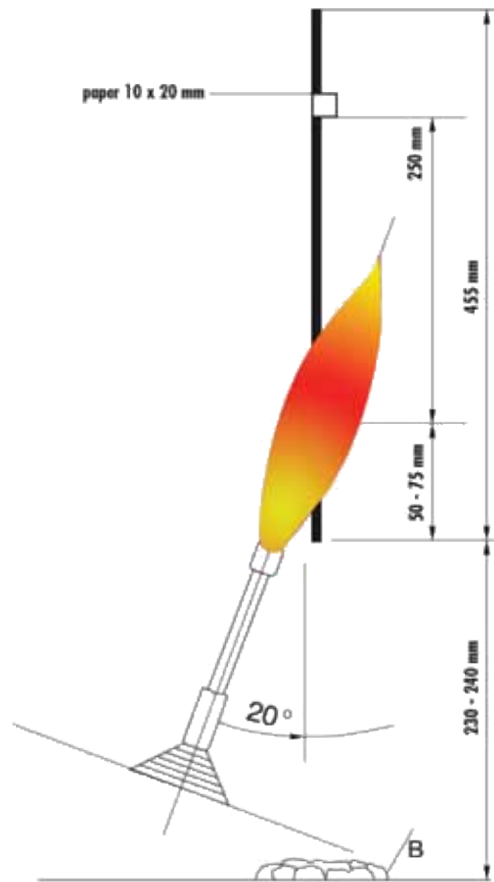

FLAMABILITY TEST

Description	UL 1581 section 1061 (VW-1 Flame test)
Length of specimen	455 mm
Burner	Bunsen burner with additional air supply (Tirril-Gasburner) Ø 9,5 mm
Test temperature	500 W flame
Position of specimen	Vertical
Position of flame	20° to vertical specimen
Duration of flame	3 x 60 seconds with 30 seconds between each flaming
Conditions	Paper max. 25% carbonized. The specimen may keep on burning for max. 1 minute after any application. Material dropping must not ignite the cotton (B) lying under the specimen.

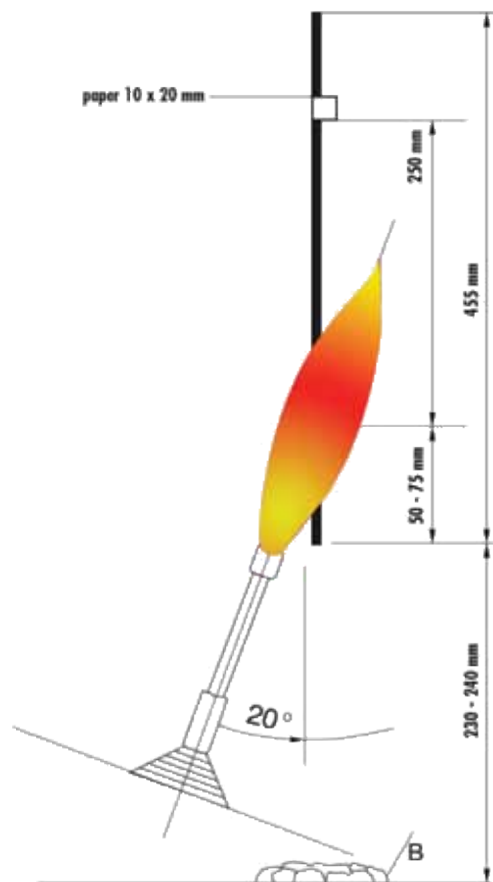

FLAMABILITY TEST

Description	UL 1581 section 1060 (Cable Flame test)
Length of specimen	455 mm
Burner	Bunsen burner with additional air supply (Tirril-Gasburner) Ø 9,5 mm
Test temperature	500 W flame
Position of specimen	Vertical
Position of flame	20° to vertical specimen
Duration of flame	5 x 15 seconds with 15 seconds between each flaming
Conditions	Paper max. 25% carbonized. The specimen may keep on burning for max. 1 minute after any application.

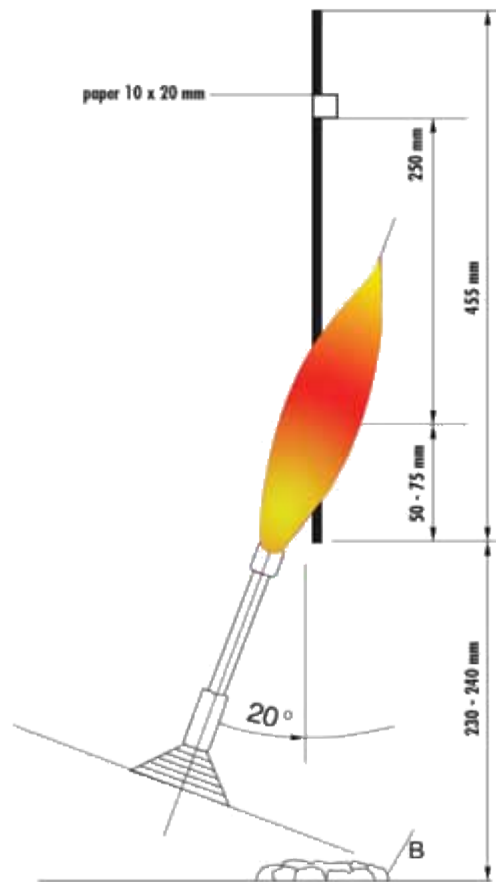

FLAMABILITY TEST

Description	UL 1581 section 1060 (Vertical Flame and FTI Test)
Length of specimen	455 mm
Burner	Bunsen burner with additional air supply (Tirril-Gasburner) Ø 9,5 mm
Test temperature	500 W flame
Position of specimen	Vertical
Position of flame	20° to vertical specimen
Duration of flame	5 x 15 seconds with 15 seconds between each flaming
Conditions	Paper max. 25% carbonized. The specimen may keep on burning for max. 1 minute after any application.

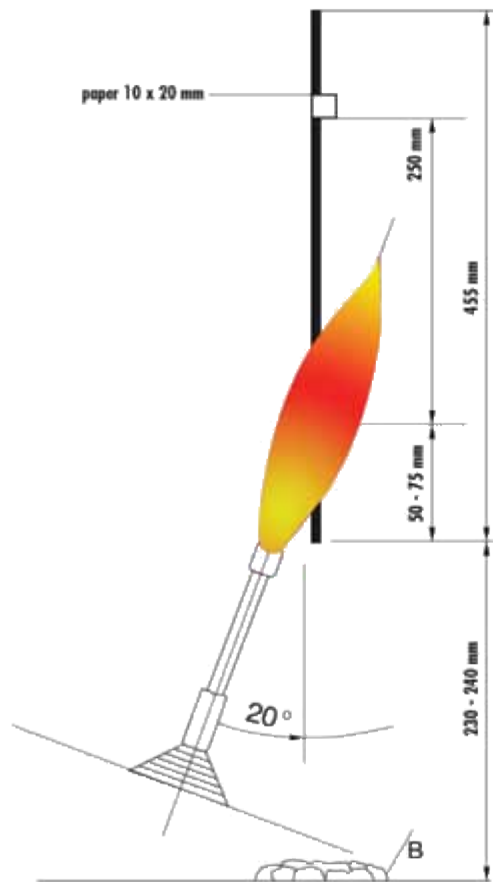

FLAMABILITY TEST

Description	NF C 32-070 "C1"
Length of specimen	455 mm
Burner	500 W flame
Position of specimen	Vertical
Duration of flame	20° to vertical specimen
Conditions	3 x 60 seconds with 30 seconds between each flaming

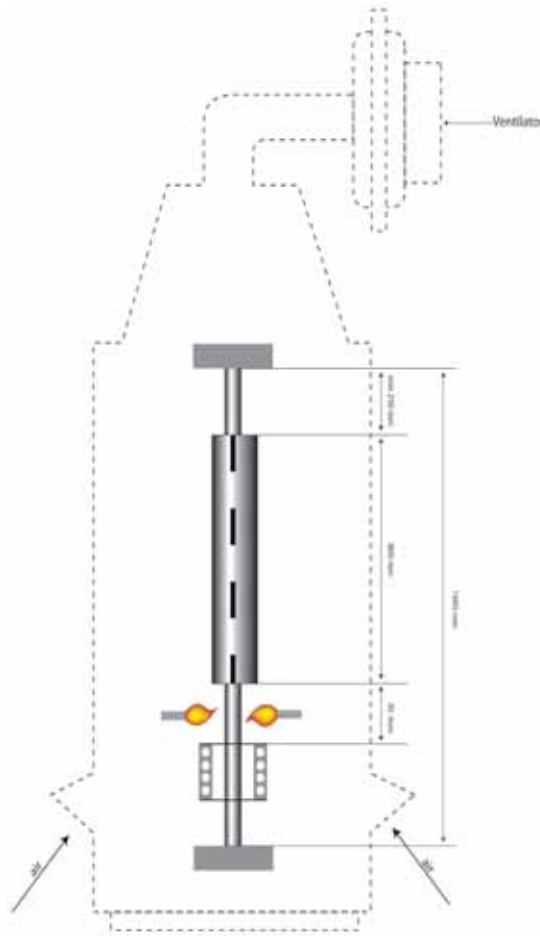

FLAMABILITY TEST

Examination of the vertical flame length of vertical extended bundle of wires and insulated cables

Description	IEC 60332-3, EN 50266, DIN VDE 0482 part. 266
Length of specimen	3500 mm
Burner	Flat burner (Ribbon gas burner of American Gas Furnace Co.)
Test temperature	500 W flame
Position of specimen	Vertical
Position of flame	Horizontal
Duration of flame	Category A, B: 40 minutes Category C, D: 20 minutes
Conditions	The burned portion of the sample must not be longer than 2,5 m measured from the bottom edge of the burner, as far as not otherwise specified in the relevant standards.

	EN 60332-	IEC 60332-
Category A-7 l/m	3/22	3/22
Category B-3,5 l/m	3/23	3/23
Category C-1,5 l/m > 12 mm cable- \varnothing	3/24	3/24
Category D-0,5 l/m \leq 12 mm cable- \varnothing	3/25	3/25
Volume percent of non metallic material per meter		

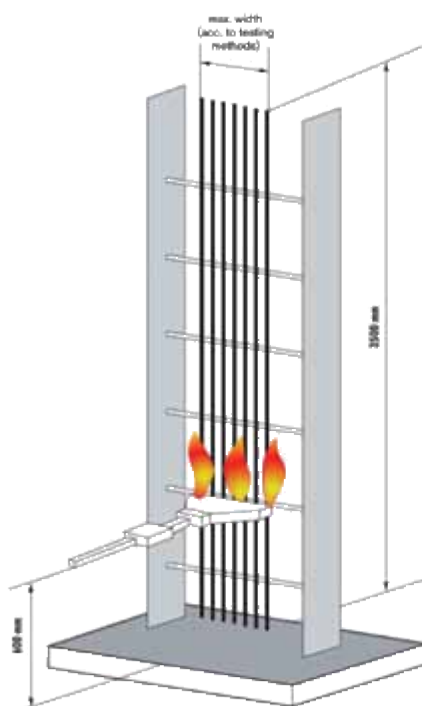

CAPACITY OF KTG POOL DRUMS

WOODEN DRUMS

Drum Type	Flange diameter D1 (mm)	Barrel diameter D2 (mm)	Overall width L1 (mm)	Winding width L2 (mm)	Maximum carrying capacity (kg)	Standard wooden drum weight (kg)
051	500	150	470	410	100	8
061	630	315	415	315	250	17
071	710	355	520	400	250	25
081	800	400	520	400	400	31
091	900	450	690	560	750	47
101	1000	500	710	560	900	71
121	1250	630	890	670	1700	144
141	1400	710	890	670	2000	175
161	1600	800	1100	850	3000	280
181	1800	1000	1100	840	4000	380
201	2000	1250	1350	1045	5000	550
221	2240	1400	1450	1140	6000	710
250	2500	1400	1450	1140	7500	875
251	2500	1600	1450	1130	7500	900
281	2800	1800	1635	1280	10000	1175

PLASTIC DRUMS

Drum Type	Flange diameter D1 (mm)	Barrel diameter D2 (mm)	Overall width L1 (mm)	Winding width L2 (mm)	Maximum carrying capacity (kg)	Standard wooden drum weight (kg)
050	500	150	456	404	100	4
070	710	355	510	400	250	15
080	800	400	510	400	350	16
090	900	450	680	560	400	23
100	1000	500	704	560	500	32

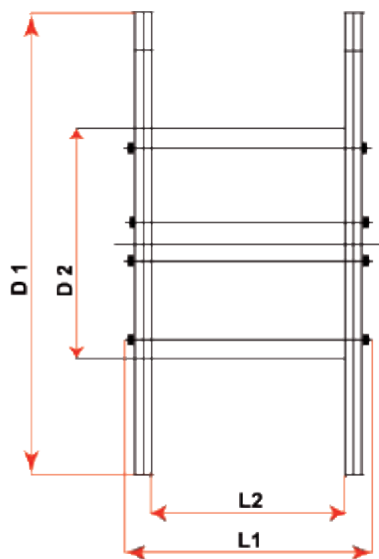

DRUM SIZE AND DRUM TYPE

Cable diameter mm	051	061	071	081	091	101	121	141	161	181	201	221	250	251	281	Cable diameter mm	
6	1130	1110	2024	2755												6	
7	815	840	1480	2340												7	
8	630	640	1064	1463	2730											8	
9	460	470	890	1152	2202	2866										9	
10	390	388	680	980	1768	2349										10	
11	320	315	564	760	1404	1910										11	
12	260	254	470	643	1206	1540										12	
13	220	238	385	542	1032	1339	2727									13	
14	190	190	360	454	880	1159	2265	2967								14	
15	170	180	300	430	749	1000	1990	2480								15	
16	150	140	239	358	632	860	1756	2205								16	
17	130	134	228	294	603	736	1545	1960								17	
18	110	102	218	280	505	705	1355	1737								18	
19	105	96	172	228	485	599	1184	1535	2722							19	
20	100	92	165	220	402	576	1139	1352	2435	2830						20	
21	80	90	159	210	387	485	990	1304	2172	2527						21	
22		65	122	167	315	468	856	1145	1930	2248						22	
23		62	117	160	304	389	827	999	1870	2172	2954					23	
24		60	113	156	294	377	709	967	1657	1927	2608					24	
25		58	110	150	285	365	688	839	1608	1867	2522					25	
26		56	80	116	226	299	668	814	1420	1650	2218					26	
27			78	113	220	290	567	700	1244	1450	2150	2860				27	
28			76	109	215	282	550	680	1210	1410	1880	2777				28	
29			73	106	209	226	462	663	1180	1370	1826	2450			2976	29	
30			70	103	165	220	450	564	1028	1200	1583	2383			2893	30	
31				76	157	214	438	550	1003	1166	1540	2089			2558	31	
32				74	153	209	428	537	866	1009	1500	2035			2490	32	
33				72	150	204	352	450	846	985	1289	1984	2978		2428	33	
34					146	158	344	440	828	962	1257	1726	2605		2134	34	
35					108	154	336	430	710	824	1227	1685	2547		2083	2890	35
36					105	150	329	422	692	806	1040	1646	2270		2035	2820	36
37					103	148	265	348	678	788	1017	1418	2223		1774	2760	37
38						144	259	340	664	772	994	1386	1969		1735	2432	38
39						110	254	334	560	653	972	1356	1930		1697	2380	39
40						105	249	327	549	640	812	1328	1892		1486	2330	40
41						102	244	264	539	627	795	1130	1664		1435	2036	41
42						100	190	259	529	615	779	1107	1633		1406	1995	42
43							187	254	437	510	763	1085	1603		1199	1956	43
44							183	249	430	502	750	1065	1574		1175	1692	44
45							180	245	422	492	610	890	1373		1153	1660	45
46							177	240	415	484	600	874	1349		1130	1630	46
47							174	187	408	475	589	858	1326		1110	1600	47
48							130	184	330	386	578	878	1144		930	1366	48
49							127	180	325	380	568	848	1125		914	1362	49
50							125	178	319	373	558	828	1107		898	1320	50
51							123	175	314	367	542	812	1089		883	1298	51
52							120	172	310	360	535	805	1072		869	1276	52
53								170	305	356	528	805	1072		869	1276	53
54								126	235	280	420	634	898		700	1056	54
55								124	232	276	414	624	885		690	1040	55
56								122	230	270	408	614	872		680	1022	56
57								121	228	267	400	608	860		668	1006	57
58								119	225	263	394	600	848		658	990	58
59								117	222	260	390	594	836		649	974	59
60									220	256	295	466	700		640	803	60
61									216	252	290	460	690		610	790	61
62									160	190	287	453	680		500	780	62
63									158	187	282	448	670		494	770	63
64									156	184	280	440	662		487	760	64
65									154	182	275	435	640		480	748	65
66									152	180	270	430	634		474	738	66
67									150	178	266	426	628		468	728	67
68										174	264	420	620		462	718	68
69										172	262	418	618		456	708	69
70										170	260	416	616		450	700	70
71										168	258	414	614		444	692	71
72										166	256	412	612		438	684	72
73										164	254	410	610		432	676	73
74										162	252	408	608		426	668	74
75										160	250	406	606		420	660	75
76										112	170	291	380		322	526	76
77										110	168	287	375		318	520	77
78										109	166	284	370		314	514	78
79										108	164	281	367		310	508	79
80										107	163	278	363		306	502	80



approx. drum barrel $\varnothing \leq 40 \times D$
 approx. drum barrel $\varnothing \leq 25 \times D$
 approx. drum barrel $\varnothing \leq 15 \times D$
 approx. drum barrel $\varnothing \leq 15 \times D$
 approx. drum barrel $\varnothing \leq 50 \times D$



ME 1. M. 7
2743-141029-00

DISC 1A

A
B
C

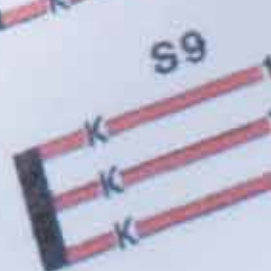
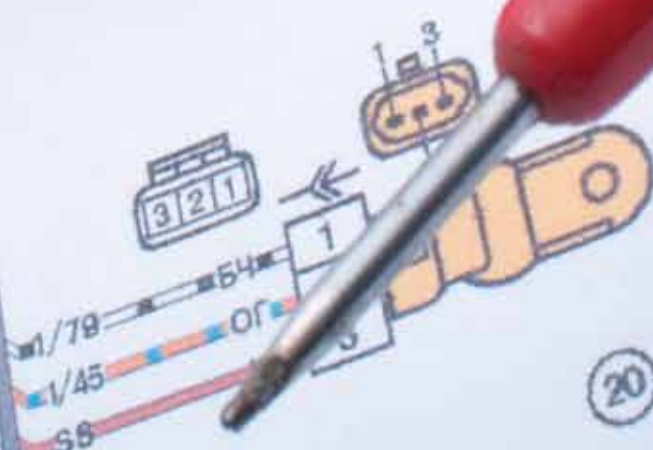
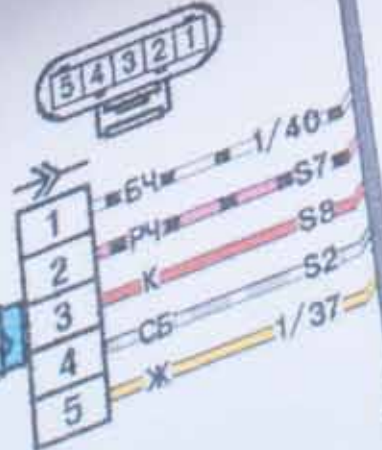
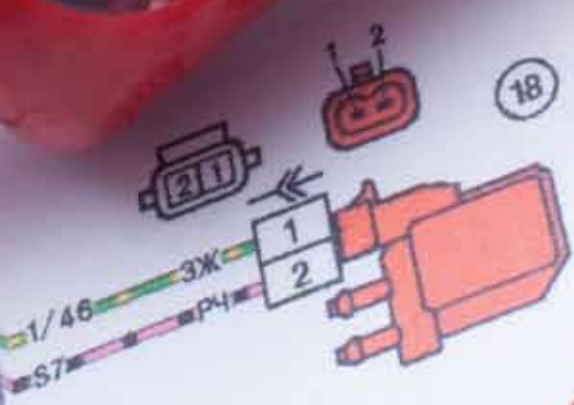
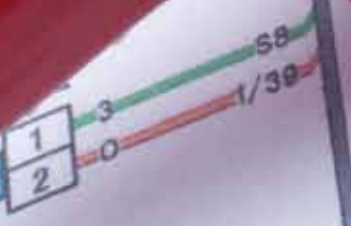

S9

Elettrotek Kabel Group
www.elettrotekkabel.com info@elettrotekkabel.com